



Submittal Data Information

SmartDRIVE VP Variable Speed Drives

301-2134

EFFECTIVE: June 21, 2018

SUPERSEDES: July 20, 2014

JOB _____ ENGINEER _____

CONTRACTOR _____ REP. _____

ITEM NO. _____

All Taco SmartDrives are Danfoss VLT FC102 variable frequency drives.

MOTOR DESIGN DATA	
HP	
Volts	
Frequency	Hz
Phase	
DRIVE DATA	
Protocols (Standard)	BACnet™, Modbus RTU, N2 Metasys, FLN Apogee, FC Protocol
Protocols (Optional)	<input type="checkbox"/> LonWorks® <input type="checkbox"/> DeviceNet <input type="checkbox"/> Profibus
Enclosure	NEMA Type 1 / IP21
I/O (Standard)	6 Digital Inputs / 2 Digital Outputs 1 Analog Current Output / 2 Analog Inputs 2 Pulse Inputs 2 Form C Relays
Additional Control Options	<input type="checkbox"/> None <input type="checkbox"/> General Purpose I/O <input type="checkbox"/> Relay Card <input type="checkbox"/> 24VDC Supply <input type="checkbox"/> Analog I/O
Electrical Configuration	<input type="checkbox"/> 3 Contactor Bypass - Drive Fusing & Main Disconnect (5kA SCCR) <input type="checkbox"/> 3 Contactor Bypass - Main Fusing & Disconnect (100kA SCCR)
EMI/RFI Control	Integrated filter designed to meet EN61800-3
Harmonic Suppression	Dual DC-link chokes (Equivalent: 5% AC line reactor) Supporting IEEE 519-1992 requirements
Cooling	Fan-cooled through back channel
Ambient Temperature	-10°C to 45°C up to 1000 meters above sea level -14°F to 113°F up to 3300 feet above sea level
STANDARD FUNCTIONALITY and CONSTRUCTION	
User Interface	Multifunction keypad with the following features: - graphical display (shows bars and graphs) - quick setup menu - 2 level password protection - intuitive help functionality
Power Isolation	Optional integrated disconnect switch
Pump Protection	- Preventive maintenance scheduling - Dry running and end of curve protection
Energy Conservation	- Automatic energy optimizer (AEO) for accurate load matching - Energy monitoring for measuring kWh consumption - Flow compensation for locally mounted DP sensor(s)
Motor Protection	Automatic current limiting and fault protection as standard
Condensation Protection	Motor pre-heat function to prevent condensation build up
TACO SYSTEM LOGIC (TSL)	
Program	<input type="checkbox"/> None <input type="checkbox"/> Delta P <input type="checkbox"/> Delta T <input type="checkbox"/> Booster System
Program Options (See <i>Specifications: Programming</i> for definitions)	<input type="checkbox"/> 1x1 <input type="checkbox"/> 2x1* <input type="checkbox"/> 2x2* <input type="checkbox"/> 2x3* <input type="checkbox"/> 3x1** <input type="checkbox"/> 3x2** <input type="checkbox"/> 3x3**
Control Relay Box (CRB) 12"L x 12"H x 6"W	<input type="checkbox"/> 9' Conduit <input type="checkbox"/> 15' Conduit
Control Relay Harness (CRH)	<input type="checkbox"/> 9' Conduit <input type="checkbox"/> 15' Conduit
Notes: * Program requires a Control Relay Harness ** Program requires a Control Relay Box and General Purpose I/O Control option	

MECHANICAL DRAWINGS

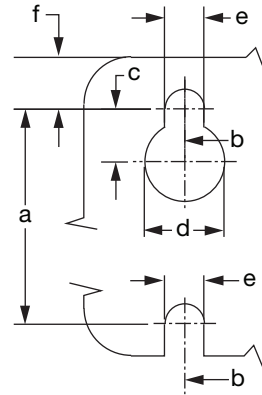
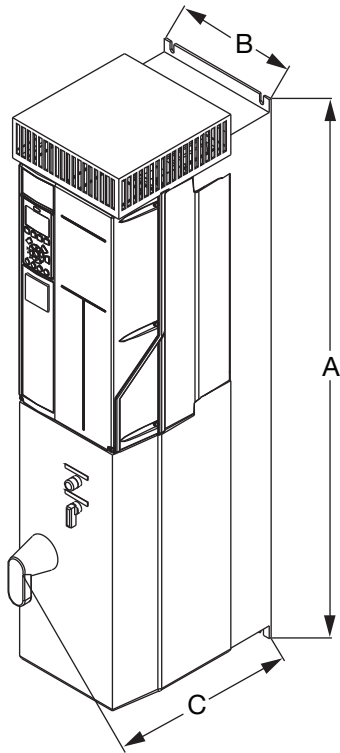

A2, A3 and B1 Frames only (4x mounts)

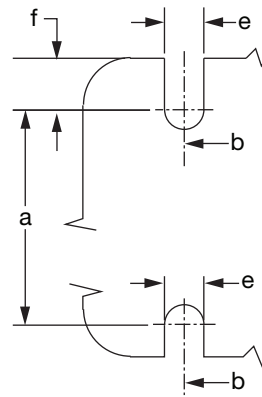

B2, C1 and C2 Frames only (4x mounts)

MAXIMUM DIMENSIONS and WEIGHTS

Frame Size	Power Range – HP (kW)			NEMA Type 1 / IP21 Inches (mm)			Max Weight Lbs (Kg)
	200V - 240V	480V	525V - 600V	A	B	C	
B1	7.5 (5.5) - 15 (11.0)	15 (11.0) - 25 (18.0)	15 (11.0) - 25 (18.0)	41.8 (1061)	9.1 (231)	15.9 (405)	51 (23)
B2	20 (15.0)	30 (22.0) - 40 (30.0)	30 (22.0) - 40 (30.0)	43.2 (1098)	9.6 (243)	17.7 (450)	60 (27)
C1	25 (18.0) - 30 (22.0)	50 (37.0) - 75 (55.0)	50 (37.0) - 75 (55.0)	54.4 (1381)	12.7 (322)	18.0 (457)	99 (45)
C2	40 (30.0) - 60 (45.0)	100 (75.0) - 125 (90.0)	100 (75.0) - 125 (90.0)	59.6 (1515)	15.1 (384)	18.0 (457)	143 (65)

BACKPLATE MOUNTING HOLE DIMENSIONS – Inches (mm)

Frame Size	a	b	c	d	e	f
B1	41.02 (1042)	7.87 (200)	0.32 (8)	0.47 (12)	0.27 (6.8)	0.35 (9)
B2	41.18 (1046)	7.87 (200)	N/A	N/A	0.33 (8.5)	0.39 (10)
C1	51.89 (1318)	10.63 (270)	N/A	N/A	0.33 (8.5)	0.59 (15)
C2	57.09 (1450)	12.99 (330)	N/A	N/A	0.33 (8.5)	0.59 (15)

SPECIFICATIONS:

DRIVE INPUT POWER	
Input voltage, 3 phase	200–240, or 380–460, or 525–600 VAC
Input voltage range for full output	Nominal ±10%
Undervoltage trip point	164, 313 VAC, or 394 VAC
Overvoltage trip point	299, 538, or 690 (792 for 100 HP and above) VAC
Input frequency	50 or 60 Hz, ± 2 Hz
Displacement power factor	0.98 or greater at all speeds and loads
Total power factor	0.90 or greater at full load and nominal motor speed
DRIVE OUTPUT POWER	
Output frequency	Selectable 0 to 120 Hz
Motor voltages	200, 208, 220, 230; 380, 400, 415, 440, 460; 550 or 575 VAC
Continuous output current	100% rated current
Output current limit setting	Adjustable to 110% of drive rating
Current limit timer	0 to 60 seconds or infinite
Adjustable maximum speed	From minimum speed setting to 120 Hz
Adjustable minimum speed	From maximum speed setting to 0 Hz
Acceleration time	To 3,600 seconds to base speed
Deceleration time	To 3,600 seconds from base speed
Breakaway torque time	0.0 to 0.5 seconds (1.6 times motor nameplate current)
Start voltage	0 to 10%
DC braking time	0 to 60 seconds
DC braking start	0 to maximum frequency
DC braking current	0 to 50% of rated motor current
ENVIRONMENTAL LIMITS	
Efficiency	97% or greater at full load and nominal motor speed
Ambient operating temperature	14°F to 113°F (–10°C to 45°C) frames A2–C2 14°F to 104°F (–10°C to 40°C) frames D1–E1
Humidity	< 95%, non-condensing
Altitude (maximum without derating)	3,300 ft. (1,000 m)
Drive and options enclosure(s)	NEMA/UL Type 1, 12 and 4X (for outdoors)
PROTECTIONS	
Low frequency and high frequency warnings	0 to 120 Hz
Low current and high current warnings	0 to maximum current
Low reference and high reference warnings	–999,999 to 999,999
Low feedback and high feedback warnings	–999,999 to 999,999
Ground fault	Protected
Motor stall	Protected
Motor overtemperature	Protected (Predictive motor temperature)
Motor condensation	Protected (Motor preheat circuit)
Pump no-flow	Protected
Pump end-of-curve	Protected
Dry pump	Protected
Short-cycle	Protected
Motor overload	Protected (Programmable action)
Vibration protection	Protected (Programming automated)
CONTROL CONNECTIONS	
Analog input (follower signal)	2; selectable voltage or current, direct and inverse acting
Digital inputs (programmable)	6 (2 can be used as digital outputs)
Analog outputs (programmable)	1; 0/4 to 20 mA
Relay outputs (programmable)	2 standard Form C 240 V AC, 2 A; 1 or 3 additional optional
Auxiliary voltage	+24 V DC, maximum 200 mA
Communication port	1 RS485, 1 USB
CONTROL OPTIONAL	
General Purpose I/O – DDA130B1125 (MCB 101)	3 DI, 2 DO, 2 AI (voltage), and 1 AO (current)
Relay Card – DDA130B1110 (MCB 105)	3 standard Form C 240 VAC, 2 A
24V DC Supply – DDA130B1108 (MCB 107)	Allows external 24 V DC power to be connected to the VLT HVAC Drive
Analog I/O (battery backup included) – DDA130B1143 (MCB 109)	3 AO (voltage), 3 AI (voltage or PT1000 or NI1000)

SPECIFICATIONS (continued):

SOFTWARE	
Lost speed reference action	Selectable to go to a preset speed, go to maximum speed, stay at last speed, stop, turn off, or stop and trip
Time delay for lost speed reference action	1 to 99 seconds
Adjustable auto restart time delay	0 to 600 seconds
Automatic restart attempts	0 to 20 or infinite
Automatic restart time delay	0 to 600 seconds between each attempt
Relay ON delay and relay OFF delay	0 to 600 seconds
Maximum number of preset speeds	16
Maximum number of frequency stepovers	4
Maximum stepover width	100 Hz
Maximum number of accel rates	4
Maximum number of decel rates	4
Delayed start	0 to 120 seconds
PROGRAMMING	
1x1	1 drive for 1 zone
2x1, 2x2, 2x3	2 drives for 1 zone, 2 drives for 2 zones, 2 drives for 3 zones
3x1, 3x2, 3x3	3 drives for 1 zone, 3 drives for 2 zones, 3 drives for 3 zones
Notes: Delta T applications can only be selected for 1 zone options.	

DRIVE FEATURES – OPERATOR INTERFACE:

SmartDRIVE HVAC Drive

The SmartDRIVE HVAC drive is a microprocessor-based, high frequency IGBT-based, PWM AC drive with control functions and software designed for the unique needs of HVAC systems. The SmartDRIVE HVAC drive uses state-of-the-art Voltage Vector Control to supply full rated motor voltage at rated load and frequency, full motor performance without derating, high efficiency for both drive and motor, and a nearly perfect output sine wave. The diode-bridge rectifier and DC-link choke provide a high displacement power factor at all speeds and loads and minimize power line harmonics. The SmartDRIVE HVAC drive utilizes a common user interface for all units.

Fully Graphic, Multilingual Display

The SmartDRIVE HVAC drive uses a large, bright, backlit graphic display to provide complete drive information at a glance. The logical arrangement of all elements simplifies the setup, operation and monitoring of the drive. Choose from 25 different items to display, including input reference, motor current, hours run, output frequency, horsepower, kW or kWh. Or select from custom units, such as GPM or HP and calibrate the maximum value to the maximum frequency of the unit. After programming one drive, the keypad can be used to transfer the same settings to all other drives. Drive can run without the keypad in place to assure tamper-proof operation. Drive status is shown even with the keypad removed.

LED Indication

Three LEDs are provided on the SmartDRIVE HVAC drive for indication of power applied, warning and fault. Upon power up, all LEDs will briefly light as a lamp test.

- Alarm** – Will flash red when the drive has registered a fault condition which has caused the drive to shut down.
- Warning** – Will flash yellow to indicate a situation exists that exceeds the normal drive/system parameters, and if that condition continues, a trip may be imminent.
- On** – Will glow green to indicate that the VFD is connected to AC power (line voltage is present).

Operating Keys

- Hand On** – Starts the drive regardless of remote start/stop contact (assuming safety interlock is closed). The speed of the drive will generally be controlled manually via the keypad "+" and "-" buttons.
- Off** – Shuts the drive down regardless of other commands.
- Auto/On** – The drive will start and stop via the external contact closure (building automation time clock). The speed is generally controlled via the building automation signal (4 to 20 mA, 0 to 10 V DC, etc.).
- Reset** – Will reset any trip level fault (not trip lock) if the drive is not set for infinite automatic fault resets.

Directional Keys

- Right / Left / Up / Down arrows** – Used as the electronic potentiometer to manually control the speed in the Hand/Start mode. All four keys are active during operation as well as programming. They provide the ability to move the cursor around the display, or sequence through display values.

Programming Keys

- Status** – Used to display operational data and status.
- Cancel** – Used to cancel the last programming command so the change is not carried out.
- OK** – Used to confirm that the last programming change should be saved to memory.
- Back** – Used to exit present display or menu to the previous display or menu.
- Quick Menu** – Used for programming the SmartDRIVE HVAC Drive for the most typical applications.

- Main Menu** – Used to access all parameters for programming. It can switch directly from this mode to quick menu.
- Alarm Menu** – Used to access all fault and warning data.
- Info Key** – Accesses an on-board manual that gives detailed explanation of a parameter.

DRIVE FEATURES – PROGRAM OPTIONS:

Application-Specific Software

The SmartDRIVE HVAC drive was designed specifically for the HVAC market and is ready to use, out of the box. This eliminates the time-consuming and often confusing job of selecting the correct parameters in the field. For the advanced user, the parameters are logically grouped, making modifications simple. Customized text fields are available to show user specific data. Four independent setups are available for unmatched flexibility.

Menu Structure

- Quick Setup Menu** – Contains the 14 required setup parameters to easily start the application.
- HVAC Application Menu** – Easy access to the most relevant parameters for each of the most common HVAC applications.
- Personal Menu** – Contains up to 20 user-selectable parameters for customized access.
- Changes Made Menu** – Provides easy access to previously modified parameters

Keypad Features

- Hot-pluggable with upload and download capabilities
- On-screen scroll bars and graphs
- Up to five separate meters displayed simultaneously
- Two-level password protection
- Plain language alarms and warnings
- Remote keypad mounting kits available

USB Connectivity

The SmartDRIVE HVAC drive can be remotely commissioned and monitored through a standard USB connection and Taco PC software.

DRIVE FEATURES – MOTOR AND DRIVE INTERACTION:

Constant Torque Start

The SmartDRIVE HVAC drive's constant-torque start mode provides full torque to accelerate different loads until the drive reaches the setpoint. Breakaway current can be set up to 160% for up to 0.5 seconds for starting high friction loads.

Current Limit Circuit

Adjustable from 0 to 110% of the SmartDRIVE HVAC drive's rated current (factory set at 110%). If during acceleration the current required to accelerate the load exceeds the current limit, the SmartDRIVE HVAC drive will stop accelerating until the motor current is reduced to normal levels, at which time the load will continue to accelerate at the rate set by the acceleration time.

Three-Phase Output Current Measurement

The SmartDRIVE HVAC drive's software measures output current on all three phases. Phase grounding is detected instantly. Output contactors may be repeatedly used with no damage to the drive. Multiple motors may be run from one drive.

Advanced Motor Protection

The SmartDRIVE HVAC drive features integrated electronic, thermal motor protection. The VFD calculates the motor temperature based on current, frequency, and time. This system allows for changing cooling conditions as speed and load vary. The drive can predict motor overheating and reports a % of thermal load.

Motor Preheat Circuit

This preheat function can be activated to avoid condensation on the motor windings when it is stopped.

Stall Protection

The SmartDRIVE HVAC drive provides protection against a stalled motor. When activated, this function can provide a warning or a fault condition caused by excessive motor current at low speeds.

DRIVE FEATURES:

DC-Link Choke

A dual, 5% DC-link choke on the positive and negative rails of the DC bus is standard equipment on the SmartDRIVE HVAC drive. This choke reduces the level of harmonics reflected back into the building power system without causing a voltage loss at the drive's input and reducing efficiency as an external AC line choke would. This choke also improves input power factor. The choke is non-saturating (linear) to provide full harmonic filtering throughout the entire load range. In performance, the DC-link choke is equivalent to a 5% AC line reactor.

Power Line Protection

Power line voltage surge protection is provided by means of input Metal Oxide Varistors (MOVs). This protects the diodes in the SmartDRIVE HVAC drive's 3-phase full wave diode bridge. The DC-link choke also acts to reduce input current caused by power line disturbances.

Sleep Mode

Automatically stops the drive when speed drops below set "sleep" level for specified time. Automatically restarts when speed command exceeds set "wake" level. Saves energy and reduces wear on driven equipment.

Run Permissive Circuit

Ability to accept a "system ready" signal assures that dampers or other auxiliary equipment are in the proper state for drive operation. This feature also provides the ability for the drive to send a "start signal applied" signal to the system to notify the auxiliary equipment of the drive's request to start.

Firefighter's Override Mode

Overrides all other commands to provide desired operation. Ignores most alarms including overload, overcurrent, overtemperature, and phase loss. When used with bypass, selectable to run from drive, from bypass, or switch from drive to bypass in the event of a drive failure.

Acceleration / Deceleration Rates

The SmartDRIVE HVAC drive can provide four individually controlled sets of acceleration/deceleration rates each from 1 to 3600 seconds. The shape of these curves may be automatically contoured to prevent tripping.

Plenum Rated

The SmartDRIVE HVAC drive (UL type 1 or UL type 12) is recognized by UL for installation in air handling compartments. UL type 4X is recognized for installations outdoors.

Auto Restarts

The SmartDRIVE HVAC drive can be automatically restarted up to 20 times or infinitely at 0 to 600 second intervals. If the application

causes the drive to trip more than the number of trials set, the drive will stop operating and display the fault on the display screen. A manual reset will be required by means of the reset key, a digital input, or EIA-485 command. In cases of severe trips, as a safety feature, the drive's input power may have to be cycled to restart a fault.

Carrier Frequency

By using IGBTs, the SmartDRIVE HVAC drive can employ high switching frequencies, so the motor current is practically sinusoidal. Audible motor noise can also be minimized by adjusting the switching frequency. These frequencies can be set or adjust themselves automatically to fit the application.

Input Power

The SmartDRIVE HVAC drive is equipped with an automatic sustained power or phase loss circuit. The SmartDRIVE HVAC drive will provide a full rated output with an input voltage as low as 90% of the nominal. The drive will continue to operate with reduced output with an input voltage as low as 164 volts for 208/230 volt units, 313 volts for 460 volt units, and 394 volts for 600 volt units.

Automatic Motor Adaptation (AMA)

Knowing motor stator resistance, the drive automatically optimizes performance and efficiency. The motor does not have to be run or decoupled from the load for the AMA setup to be performed.

Automated Frequency Avoidance / Critical Frequency Lockouts

For applications where it may be necessary to avoid specific frequencies due to mechanical resonance problems in the driven equipment, the SmartDRIVE HVAC drive, with its Critical Frequency Lockout Function, makes it possible to set up to four different frequency ranges which will be avoided during operation of the drive. This feature can be programmed by simply activating the feature and pushing OK at the top and bottom points that you wish to avoid.

- Each critical frequency setting can avoid a frequency band which is from 1 to 100 Hz wide. If the reference signal defines that the SmartDRIVE HVAC drive is to operate within this critical frequency range, the critical frequency lockout function will keep the drive operating continuously within this range.
- When the frequency reference signal rises above the critical frequency maximum limit, the SmartDRIVE HVAC drive will allow the motor to accelerate through the critical frequency at the rate set by the acceleration rate.

Automatic Energy Optimization Circuitry

The Automatic Energy Optimization (AEO) function adapts the output of the drive to the specific motor and load connected. This circuit optimizes the system efficiency as system loads change. The AEO function regulates the output voltage on the basis of the reactive current and the effective current. A savings of 3 to 10% in power consumption can be obtained with this function.

Preset Speeds

The SmartDRIVE HVAC drive allows for a maximum of 16 programmable preset speeds to be selected from the digital inputs.

Energy Monitoring

Real energy savings are always available without the additional expense of external equipment.

Real-Time Clock

Adds sophisticated performance to basic control schemes for increased comfort and energy savings.

Automatic High Ambient Derate

If the ambient temperature exceeds the normal limit, the drive can be set to warn of its overtemperature and continue to run, keeping the HVAC system functional. To control its temperature, the drive will reduce the output carrier frequency and then, if necessary, reduce the output current.

Preventive Maintenance Scheduling

The SmartDRIVE HVAC drive can monitor system usage and notify the operator when preventive maintenance is required.

Intelligent HVAC Controller

Four auto-tuning PIDs control the drive and up to three other devices, eliminating external controllers and reducing cost.

- Proportional: The proportional gain dictates the rate at which the deviation between actual and desired feedback signal is corrected. The higher the gain, the faster the response, but too high a gain can cause hunting and a large overshoot.
- Integral Time: The integral time continually compares the feedback value with the desired setpoint over time to make sure the setpoint is reached. The greater the integral time, the longer it takes to actually achieve the setpoint, but improves the system stability.
- Derivative: The derivative function monitors the rate at which the feedback is closing on the desired setpoint and slows the rate of approach to prevent overshooting. This function allows rapid accurate system control.

Built-in Communications

The SmartDRIVE HVAC drive is fully equipped for serial communication (EIA-485). Up to 31 drives can be connected to one serial bus up to 5,000 feet long.

Communicates directly with Johnson Controls Metasys (N2), Siemens Building Technologies System 600 (FLN), BACnet, FC Protocol and Modbus RTU systems with no hardware changes or additional costs.

Optional communications include LonWorks, DeviceNet and Profibus with the addition of an Option A card.

Broken Belt, Loss of Load

A minimum motor current value can be set to indicate the motor is not using any more current than to run at idle. This can be used to indicate a broken belt or coupler. This feature can also be used to detect when a motor is disconnected from the drive.

3 CONTACTOR BYPASS DRIVE FUSING & MAIN DISCONNECT (5kA SCCR) ELECTRICAL SCHEMATIC

WIRE COLOR SCHEME
 BLACK - LINE VOLTAGE
 RED - AC CONTROL
 WHITE - AG GROUND
 BLUE - AC INDUCTOR
 BLUE - DC CONTROL
 WHI/BLU - DC CONTROL COMMON
 GREEN - CHASSIS GROUND

177R0254

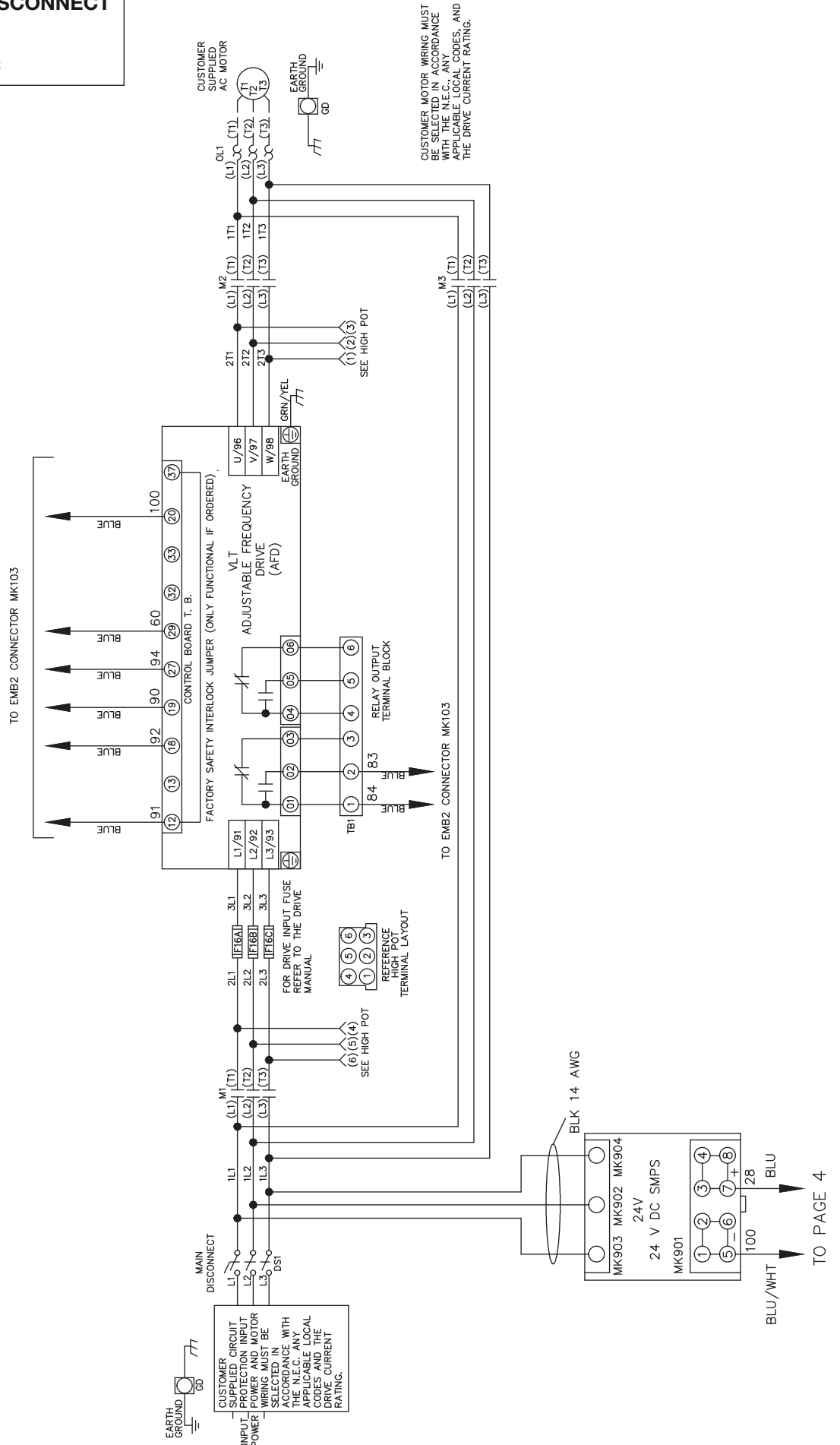

**3 CONTACTOR BYPASS
DRIVE FUSING & MAIN DISCONNECT
(5kA SCCR)
ELECTROMECHANICAL BOARD**

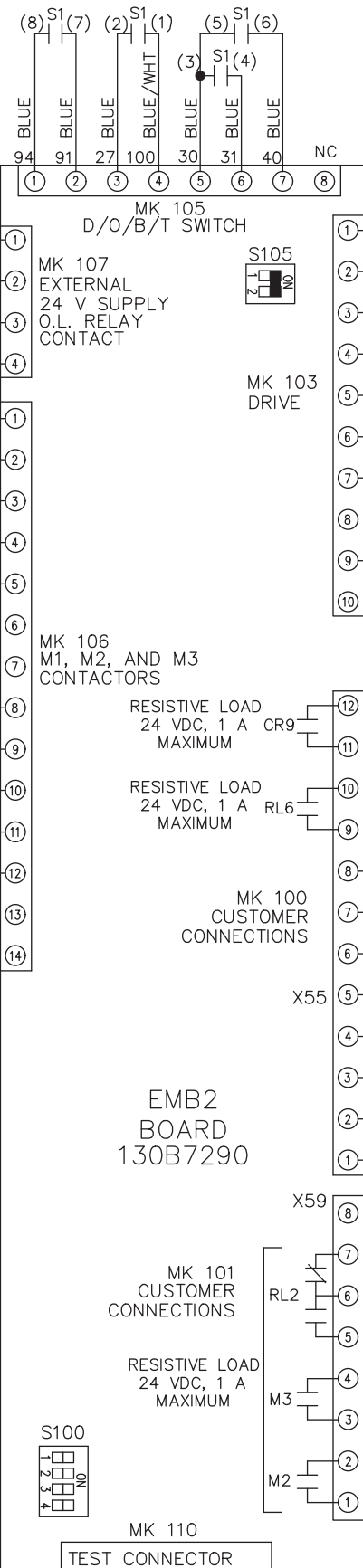

CONTACT SEQUENCE CHART FOR S1
X INDICATES CONTACT CLOSED

POSITION	DRIVE	OFF	BYPASS	TEST
1-2	X			X
3-4			X	X
5-6	X			
7-8				X

CUSTOMER CONNECTIONS X55, X59
CLASS 2 POWER SOURCE
REQUIRED FOR FIELD CONNECTION
USE CLASS 1 CONDUCTORS
CONDUCTOR SIZE 28-14 AWG

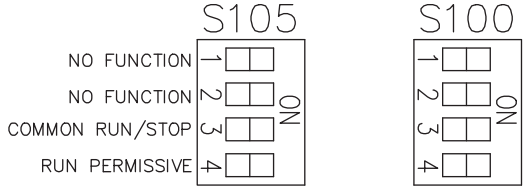
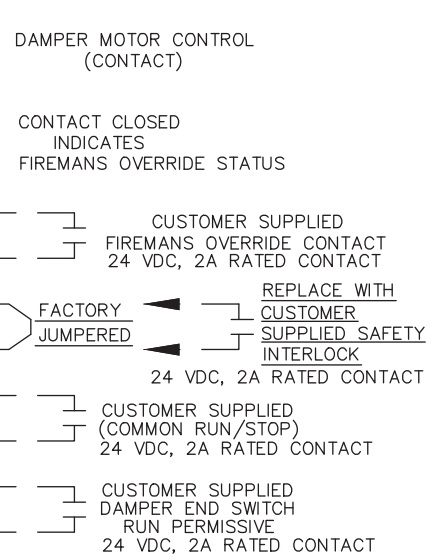
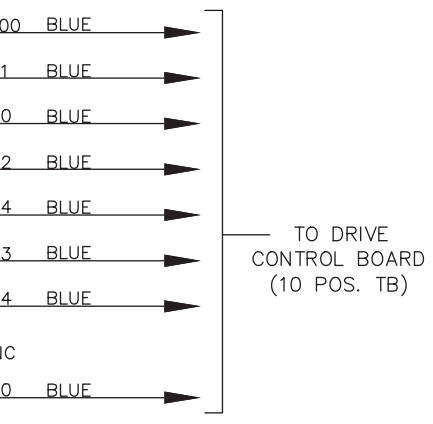
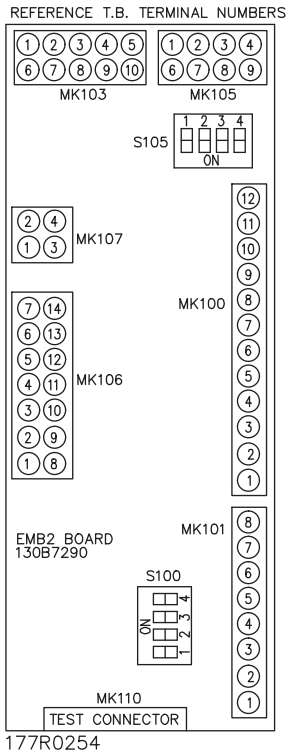

CUSTOMER SETTING
AUTOMATIC BYPASS TIME SELECT
ONLY # 1 ON 30 SECONDS
ONLY # 2 ON 60 SEC.
ONLY # 3 ON 300 SEC
ALL ON 15 SEC.
ALL OFF NO AUTO BYPASS (FACTORY DEFAULT)

3 CONTACTOR BYPASS MAIN FUSING & DISCONNECT (100kA SCCR) ELECTRICAL SCHEMATIC

WIRE COLOR SCHEME
 BLACK - LINE VOLTAGE
 RED - AC CONTROL
 WHITE - AC GROUND
 BLUE - CIRCUIT CONDUCTOR
 BLU - DC CONTROL
 WHT/BLU - DC CONTROL COMMON
 GREEN - CHASSIS GROUND

177R0255

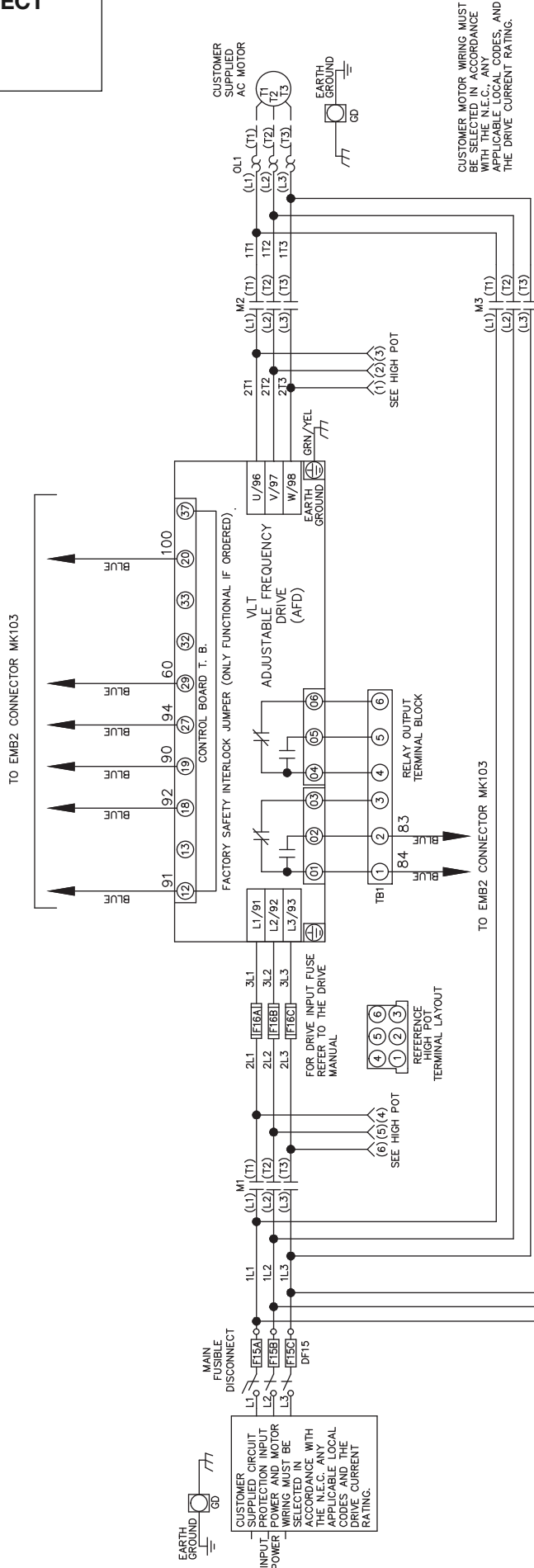

CUSTOMER MOTOR WIRING MUST BE SELECTED IN ACCORDANCE WITH THE N.E.C., ANY APPLICABLE LOCAL CODES, AND THE DRIVE CURRENT RATING.

**3 CONTACTOR BYPASS
MAIN FUSING & DISCONNECT
(100kA SCCR)
ELECTROMECHANICAL BOARD**

CONTACT SEQUENCE CHART FOR S1
X INDICATES CONTACT CLOSED

POSITION	DRIVE	OFF	BYPASS	TEST
1-2	X			X
3-4			X	X
5-6	X			
7-8				X

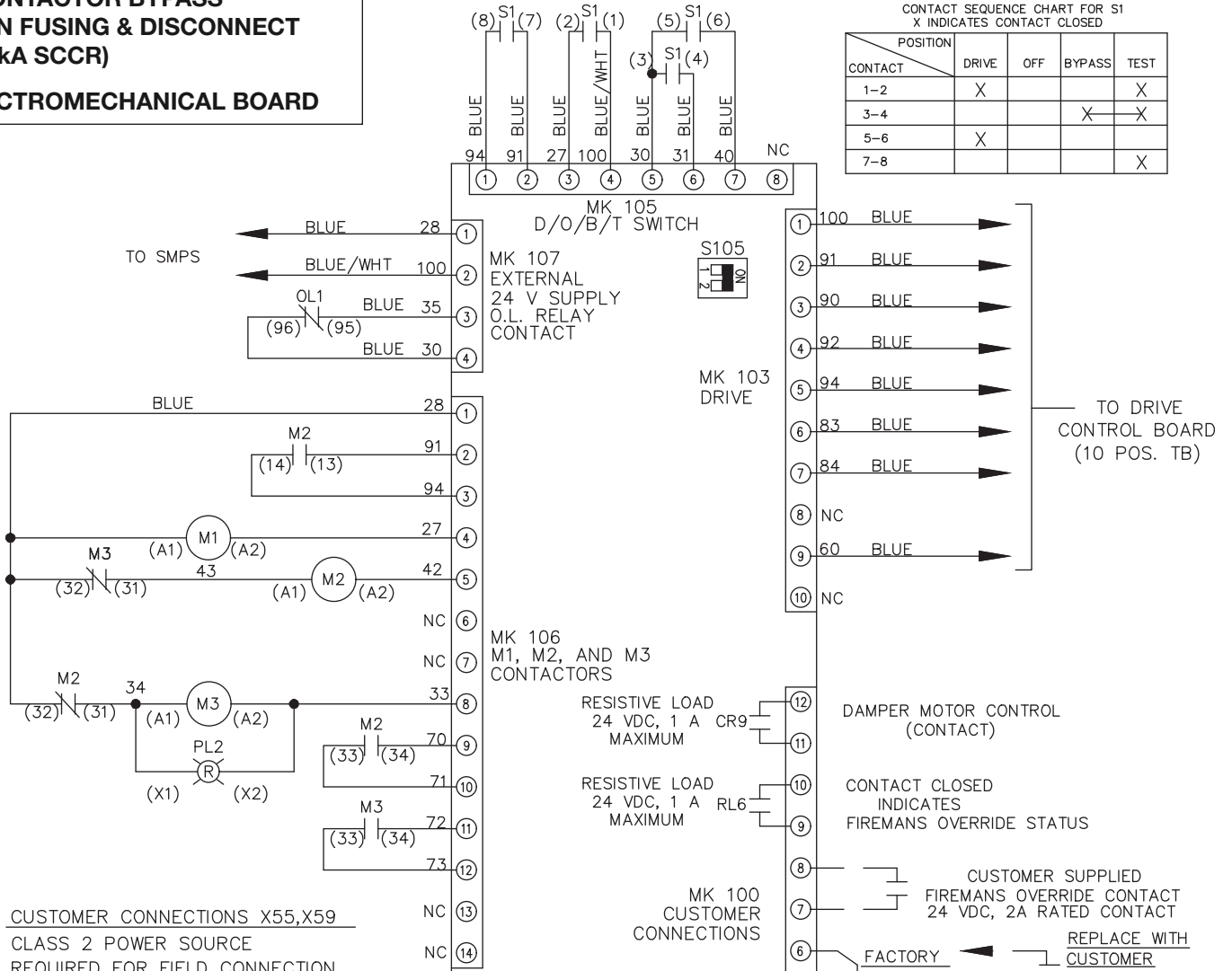

CUSTOMER CONNECTIONS X55, X59
CLASS 2 POWER SOURCE
REQUIRED FOR FIELD CONNECTION
USE CLASS 1 CONDUCTORS
CONDUCTOR SIZE 28-14 AWG

REFERENCE T.B. TERMINAL NUMBERS

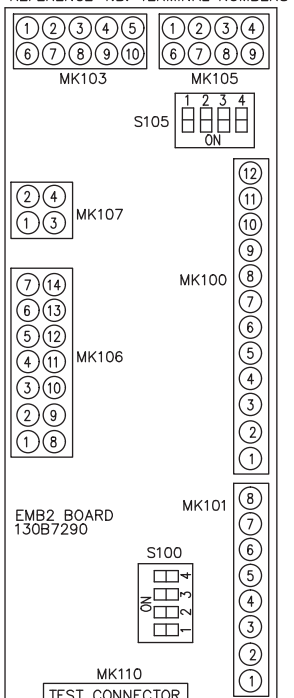

177R0255

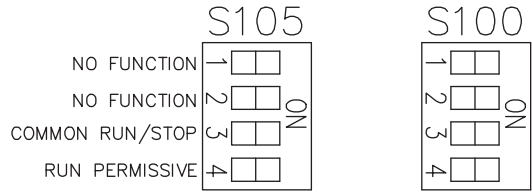
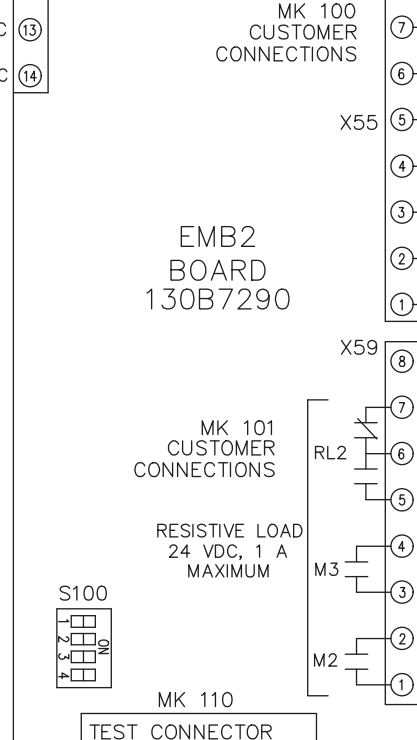

CUSTOMER SETTING
AUTOMATIC BYPASS TIME SELECT
ONLY # 1 ON 30 SECONDS
ONLY # 2 ON 60 SEC.
ONLY # 3 ON 300 SEC
ALL ON 15 SEC.
ALL OFF NO AUTO BYPASS (FACTORY DEFAULT)

 **Taco Comfort Solutions**® A Taco Family Company

Taco, Inc., 1160 Cranston Street, Cranston, RI 02920 | Tel: (401) 942-8000 | FAX: (401) 942-2360

Taco (Canada), Ltd., 8450 Lawson Road, Suite #3, Milton, Ontario L9T 0J8 | Tel: (905) 564-9422 | FAX: (905) 564-9436

Visit our web site: www.TacoComfort.com | Printed in USA | ©2017 Taco, Inc.

