

## Installation, Operation & Maintenance Manual

SUPERSEDES: July 1, 2010

EFFECTIVE: March 26, 2019

Plant ID No. 001-1013

### INSTALLATION

#### SAFETY REQUIREMENTS

1. **IMPORTANT!** These instructions should be read completely prior to installation of the equipment. A copy of these instructions should be retained on file for future reference.
2. This pump is intended for the circulation of water or other suitable HVAC media. It is not intended for hazardous, corrosive, or flammable liquids.
3. Pump must not be operated until all piping and/or electrical connections are in place.
4. Proper care and suitable equipment should be used to move and install this heavy equipment.
5. Care should be taken when installing pipe systems to avoid placing an excessive load on the pump unions.
6. Refer to motor installation instructions to determine proper terminal connections in order to obtain correct pump rotation.
7. When the system piping is used as an earth bonding path for the building electrical services (check local codes), the pump should not be relied upon as part of the circuit. A properly installed bridging connection should be provided.
8. If electrical connection is to be made using any means other than rigid conduit, proper strain relief must be provided (min 100N tension).
9. Pump should be installed according to local electrical and safety codes using appropriate size wire and suitable over current protection. It should use a lockable isolator or circuit breaker conforming to applicable electrical codes.
10. It is recommended that the pump be fitted with a suitable "emergency stop" per the requirements of applicable electrical codes.

#### A. Receiving Pump

1. Inspect for shipping damage. If a shortage or damage occurs, contact carrier immediately.

#### B. Location

1. Install vertically with motor up. Consult factory for horizontal mounting.
2. Pump should be accessible for inspection and repair work, head room must be provided for the use of hoist or tackle as necessary.

3. Lift pump by slinging through motor eye bolts and securing through pump adapter.
4. In no case should any part of motor be covered with insulation.

#### C. Foundation

1. The pump must always be supported.
2. Pumps with smaller motors may be suspended in the piping, provided the piping is supported adjacent to the pump.
3. For pumps with larger motors, the pump should be attached to a support utilizing the tapped hole or holes in the bottom of the pump casing. **Note: Piping loads shall not be applied to the pump.**
4. Pump must be allowed to move with piping movement. Expansion of piping must be taken into account when piping and suitable devices should be employed. Do not rigidly connect the pump to the floor. **Note: Provide vibration isolation pads under floor mounted supports. Do not support unit by the motor eye-bolts.**

### OPERATION

#### A. Before operating for the first time check the following:

1. Is motor correctly wired for voltage available.
2. Has pump been primed. Pump should never be run dry. Extra effort may be required to get the air out of the seal chamber.



**Caution: Make sure power supply to pump motor is locked out before touching motor shaft.**

3. All rotating parts turn freely.

#### B. Starting pump

1. Jog pump to check proper rotation.



**DANGER: MAKE SURE SUCTION VALVE IS OPEN!!**

2. Start pump with discharge valve closed.
3. When correct pressure has been reached, open discharge valve slowly.
4. **Do not operate pump for prolonged periods with discharge valve closed, so as to avoid overheat-**

### ing and potential damaging loads.

5. Pump should be stopped if any of the following occur:
  - a. No discharge.
  - b. Insufficient discharge.
  - c. Insufficient pressure.
  - d. Loss of suction.
  - e. Excessive power consumption.
  - f. Vibration.

Check problem analysis further in the manual for help in troubleshooting.

## MAINTENANCE

### A. Routine Inspections

Routine inspections should be made on a regular basis. Inspections made while pump is running should reveal potential failures.

1. Inspect motor bearings for any sign of temperature rise. Temperature should not exceed 160°F. Temperature rise may indicate the early stages of bearing problems.
2. Listen for any unusual noise.
  - a. Air trapped in pump
  - b. Hydraulic noise.
  - c. Mechanical noise in motor and/or pump.
3. Check suction gauge reading and confirm that it is normal.
4. Check discharge gauge reading and confirm that it is normal. If gauge readings are abnormal find out why.

**Note: Suction and discharge gauges should read the same with pump stopped.**

### B. Close Coupled Pumps

The pump section is attached directly to the motor shaft and does not contain bearings.

### C. Close Coupled Motors

The motor must be lubricated in accordance with the manufacturer's recommendations. **Do not over lubricate the motor bearings as this could cause premature bearing failure.**

### D. Mechanical Seal

The mechanical seal is the "John Crane" Type 21 General Purpose Seal for the 175 psig pressure rating.

A "John Crane" Type 2 General Purpose Seal is used for the 300 psig pressure rating.

## DIS-ASSEMBLY AND RE-ASSEMBLY

### A. General

If the pump has been maintained and serviced properly, breakdowns which necessitate the pump being dis-assembled should not occur often.

1. If a problem occurs, the cause should be determined, if possible, before dis-assembling. (See "Problem Analysis")
2. If the pump is being dis-assembled, all parts must be carefully handled, avoid heavy blows and shocks.
3. All parts must be carefully cleaned and inspected for

wear. Recondition or replace parts where necessary.

### B. Dis-Assembly



**Caution: Allow pump to cool and secure suction and discharge valves before working on pump!!**

1. Drain liquid from casing by removing drain plug.
2. Remove re-circulation line.
3. Remove bolts holding cover/adaptor to casing, pry cover/adaptor and motor assembly from casing.
4. Remove impeller bolt in a counterclockwise direction. Remove impeller and key.
5. In all cases of mechanical seal arrangement, after removing the sleeve and its seal assembly, the seal rotating element may be drawn off the shaft sleeve. Note: Apply silicone grease on the OD of the sleeve in the area between the seal and the end of the sleeve. This will help removal of the old seal. The stationary element is to be removed from the cover.
6. All parts must be cleaned and inspected for wear. Replace parts where necessary.

### C. Re-Assembly

1. Be certain that all parts to be replaced are free from burrs, with screw threads and connecting faces clear and free from damage.
2. Insert stationary element of seal into cover adapter, slip cover-adaptor over shaft and engage rabbit of motor. **Note: Do not touch the seal surfaces because this may result in leakage. Do not contaminate seal faces with fingerprints.**
3. Lubricate smaller OD of shaft sleeve with silicone grease. **Do not use petroleum oil or grease.**
4. Place spring on shaft sleeve to abut against sleeve shoulder. Slide rotary seal on sleeve until it contacts spring.
5. Slide the shaft sleeve on the shaft, larger bore first. Be certain the O-ring is correctly seated in the groove.
6. Assemble impeller key and impeller on shaft. Refit with new impeller washer on impeller bolt and tighten carefully. Be certain that the impeller rotates freely by hand.
7. Apply a few spots of gasket adhesive to gasket surface of cover. Place a new casing gasket against gasket surface and press against adhesive.
8. Assemble cover-adaptor complete with motor into casing. Insure that gasket is seated correctly. Install hex-headed cap screws into casing tapings and tighten uniformly.
9. Reconnect re-circulation line and drain plug.

## APPLICATION

1. Working Pressure: 175 psig  
 Optional Working Pressure: 300 psig  
 2. Temperature: 250°F Standard  
 300°F Hi Temperature

## KV CASING/IMPELLER WEAR RING CLEARANCES

PUMP SIZE	WEAR RING-SUCTION SIDE				CLEARANCE	
	DIA $d_1$		DIA $d_2$		MAX	MIN
	MAX	MIN	MAX	MIN		
1506	2.363	2.361	2.377	2.375	.016	.012
1507	2.738	2.736	2.752	2.750	.016	.012
2006	2.863	2.861	2.877	2.875	.016	.012
2007	2.938	2.936	2.952	2.950	.016	.012
2009	3.363	3.361	3.377	3.375	.016	.012
2011	3.488	3.486	3.502	3.500	.016	.012
3006	3.238	3.236	3.252	3.250	.016	.012
3007	3.688	3.686	3.702	3.700	.016	.012
3009	3.613	3.611	3.627	3.625	.016	.012
3011	3.988	3.986	4.002	4.000	.016	.012
3013	3.738	3.736	3.752	3.750	.016	.012
4007	4.238	4.236	4.252	4.250	.016	.012
4009	4.611	4.609	4.627	4.625	.018	.014
4011	4.738	4.736	4.752	4.750	.016	.012
4013	4.613	4.611	4.627	4.625	.016	.012
5007	4.988	4.986	5.002	5.000	.016	.012
6009	5.861	5.859	5.877	5.875	.018	.014
6011	5.861	5.859	5.877	5.875	.018	.014
6013	5.861	5.859	5.877	5.875	.018	.014
8011	7.234	7.232	7.252	7.250	.020	.016
8013	7.734	7.732	7.752	7.750	.020	.016

## CASING/IMPELLER WEAR RING CLEARANCES

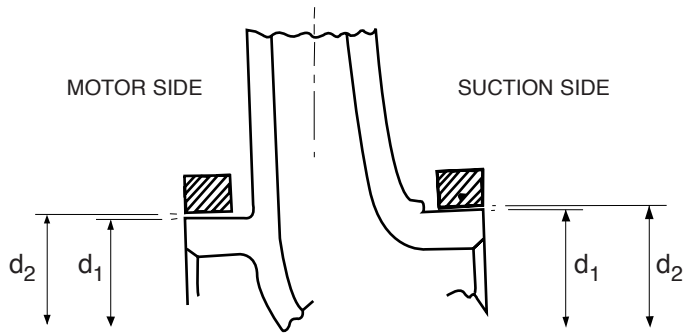

OPTIONAL CASING WEAR RING FITTED TO SUCTION SIDE ONLY

# Addendum to KV Installation, Operation & Maintenance Manual

THE FOLLOWING INSTRUCTIONS APPLY TO VERTICAL IN-LINE PUMPS UP THROUGH 10" FLANGE CONNECTIONS.

## INSTALLATION

### A1. Location

In open systems, locate the unit as close as practical to the liquid supply source, with a short, direct suction pipe. Ensure adequate space is left above and around the unit for operation, maintenance, service and inspection of parts.

In closed systems, where possible, the pumps should be installed immediately downstream of the expansion tank/ make-up connection. This is the point of zero pressure change and is necessary for effective pump operation. Do not install more than one expansion tank connection into any closed hydronic system.

Electric motor driven pumps should not be located in damp or dusty location without special protection.

Airflow into the motor and/or motor fan should not be obstructed.

### A2. Installation

In order to achieve the full added value of the Vertical In-Line pump design it is important that you ensure the pump is affixed to the system piping by the pump flanges and the pump and motor assembly is allowed to float freely with the expansion and contraction of the piping system. Should any vertical in-line pump use supports to the structure, **it is imperative that no pipe strain is imposed on the pump flanges.** Compliant mounts such as springs or "waffle" style isolation pads should be used under the pipe supports if the pump is not truly pipe mounted.

Various installation arrangements are detailed in Figures A1.1 through A1.12.

Vertical In-Line pumps may be installed directly in the system piping with no additional support. Pipe hangers are simply sized for the additional weight of the pumping unit. Many pumps are installed in this manner and are mounted at sufficient height to take zero floor space. (Figure A1.1)

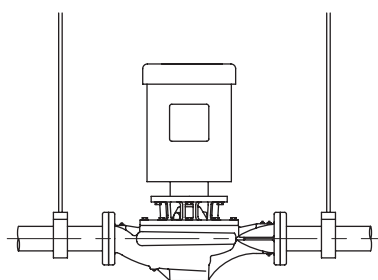

Fig. A1.1 Hanger Supported, Pipe Mounted

Piping for smaller in-line pumps (typically 15 hp and below) is hung close to the ceiling in many mechanical rooms. Larger pumps are often mounted near ground level for ease of maintenance. Figure A1.2 illustrates such an

arrangement with the piping supported at the ceiling and the vertical pump installed with a Taco Suction Diffuser (RSP) and Plus Two Multi-Purpose Valve.

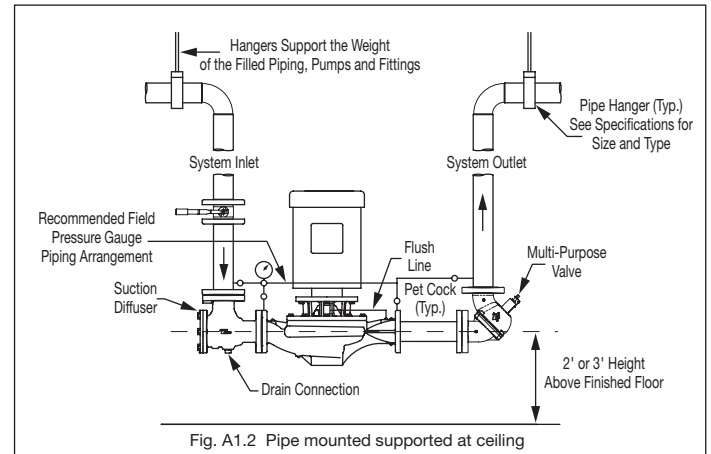

Fig. A1.2 Pipe mounted supported at ceiling

Should additional space saving be required the discharge spool piece and Plus Two Multi-Purpose Valve may be replaced by a long-radius elbow and the Plus Two Multi-Purpose Valve field converted to a straight pattern configuration and installed in the vertical discharge pipe. (Figure A1.3)

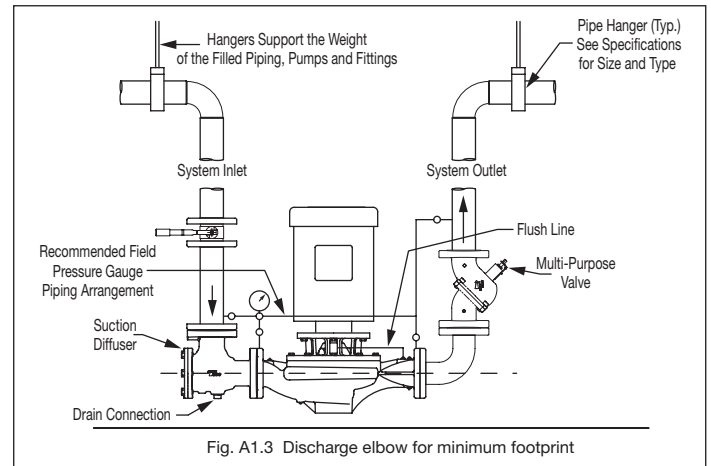

Fig. A1.3 Discharge elbow for minimum footprint

A similar arrangement to Figure A1.2 with additional floor mounted pipe-stools isolated from the structure by 'waffle' style isolation pads under the Suction Diffuser (RSP) and Plus Two Multi-Purpose Valve is illustrated in Figure A1.4.

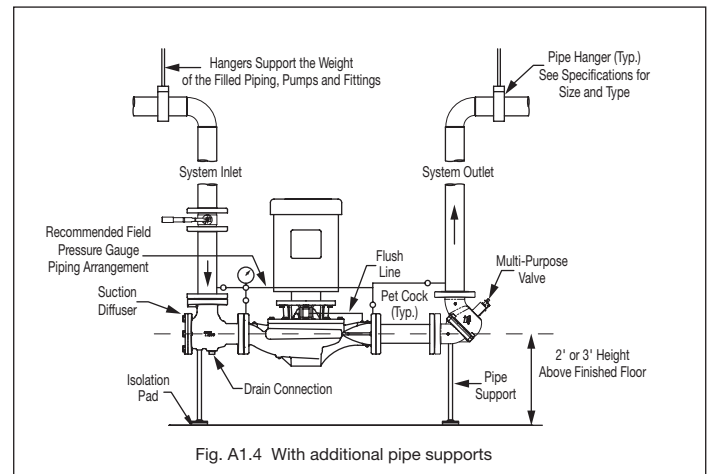

Fig. A1.4 With additional pipe supports

Floor mounted saddle supports (Figure A1.5) are typical for condenser water pumps where cooling tower base is near mechanical room elevation.

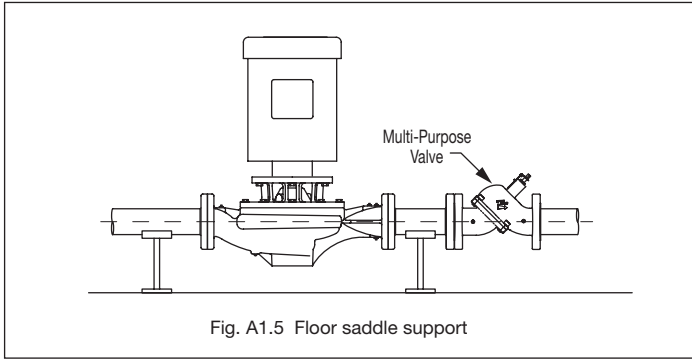

Fig. A1.5 Floor saddle support

Where required, additional floor support may be used as shown in Figure A1.6. Install a “waffle” isolation pad under the pump. **NOTE: The pump should not be rigidly attached to the base/pad structure.**

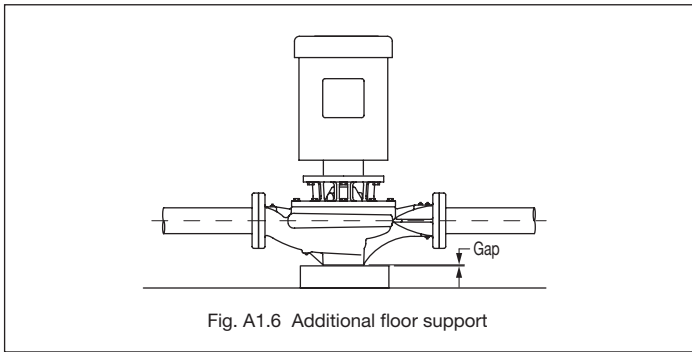

Fig. A1.6 Additional floor support

Stanchion plates at the pump suction and discharge ports may be supplied for installation convenience. Isolation pads must be used under the legs and monitored as pipe hangers are adjusted to ensure the pump flanges are not supporting the piping. Bolting to the floor or housekeeping pad is not recommended. If the stanchions are bolted down the bolts must be isolated from the stanchion or inertia base and flexible pipe connectors used (Figure A1.7).

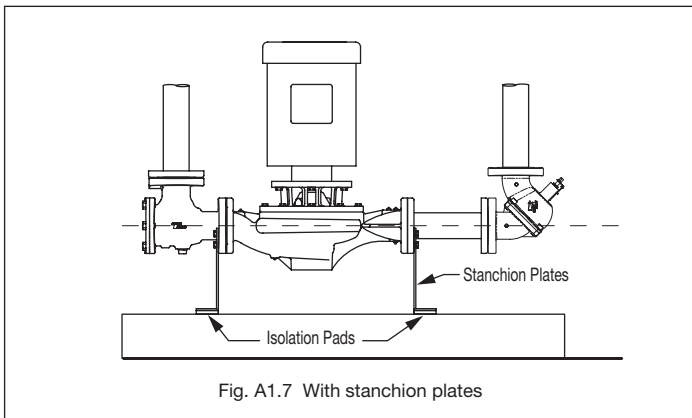

Fig. A1.7 With stanchion plates

An installation with stanchion plates for seismically active regions is illustrated in Figure A1.8. Seismically rated isolation pads or snubbers with bolts isolated from the stanchion plates are installed to restrain the pump during a seismic event. Pipe hangers carry the weight of the equipment as seismic components are designed only to restrain the equipment during a seismic event.

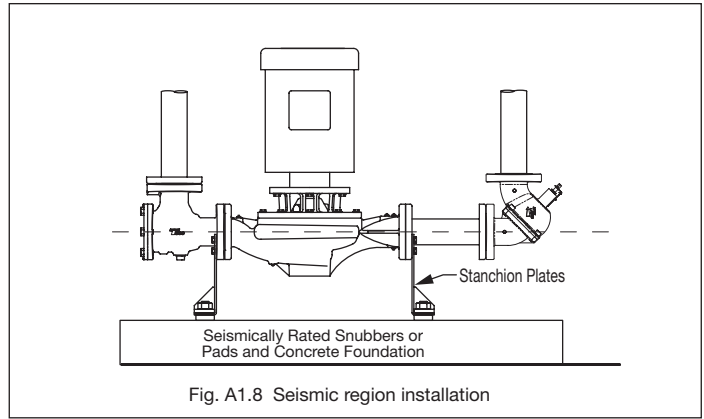

Fig. A1.8 Seismic region installation

Close coupled KV In-line pumps up to 15hp (254 frames) / 11kW may be installed with the shaft horizontal (Figure A1.9).

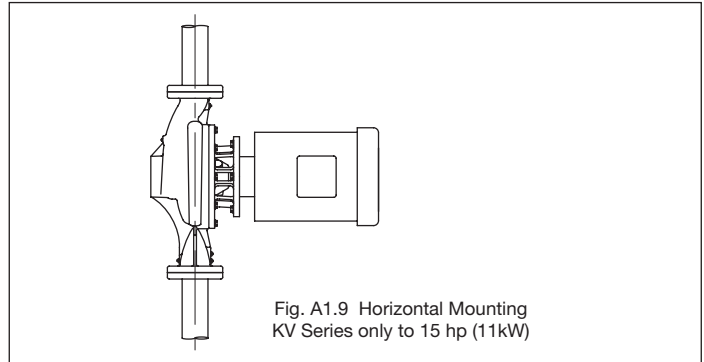

Fig. A1.9 Horizontal Mounting KV Series only to 15 hp (11kW)



**Caution: Do not support, suspend or brace motor and/or bracket. Support provided by casing is sufficient for structural integrity of the pump. Under no circumstances should any part of the bracket or motor be covered with insulation. Observe all applicable electrical and mechanical codes.**

In systems utilizing grooved pipe, flange adapter locking devices or welded flanges at the pump should be used to prevent the possibility of pipe mounted pumps rotating in the piping (Figure A1.10).

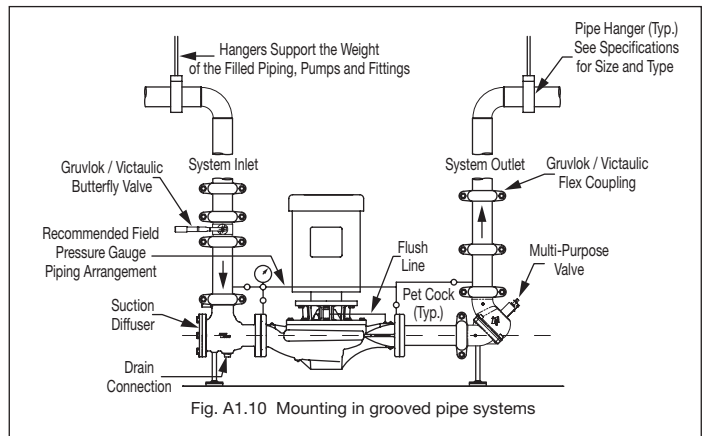
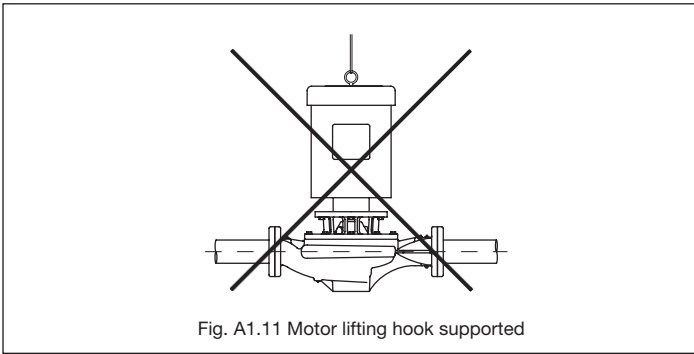
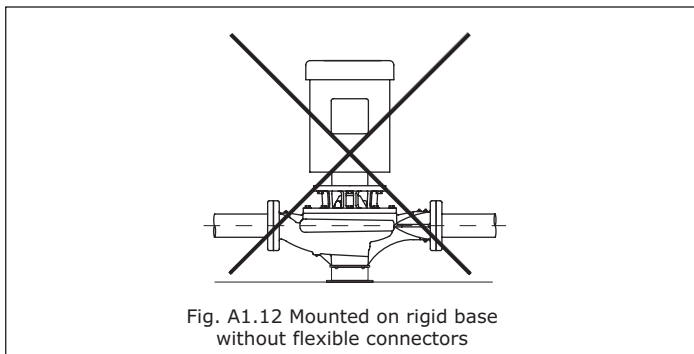

Fig. A1.10 Mounting in grooved pipe systems

**DO NOT** support the unit by the motor eye bolts (Figure A1.11) or by any other part of the motor.



Connecting the pump to a permanent rigid base (Figure A1.12) is not recommended unless isolated from the piping by flexible connectors and the base isolated from the building structure on an inertia base. (Figure A1.12 is generally acceptable when using plastic piping.)



## PUMP PIPING - GENERAL

**NEVER** connect any pump to piping, unless extra care is taken to measure and align the piping flanges well. Always start piping from pump. Use as few bends as possible and preferably long radius elbows.

Do not use flexible connectors on the suction or discharge of a vertical in-line pump, unless the pump is rigidly mounted to a foundation. Ensure piping exerts no strain on pump as this could distort the casing causing breakage or early failure due to pump misalignment. All connecting pipe flanges must be square to the pipe work and parallel to the pump flanges.

Suction and discharge pipes may be increased or decreased at pump nozzle to suit pump capacity and particular conditions of installation. Use eccentric reducers on suction connection with flat side uppermost.

Lay out the suction line with a continual rise towards the pump without high points, thus eliminating possibility of air pockets that may prevent the pump from operating effectively.

## PROBLEM ANALYSIS

### A. No Discharge

1. Pump not primed.
2. Speed too low.
3. System head too high.
4. Suction lift higher than pump is designed.
5. Impeller completely clogged.
6. Incorrect direction of rotation.
7. Air leak in suction line.

### B. Insufficient Discharge Flow

1. Air leak in suction line.
2. Speed too low.
3. System head higher than anticipated.
4. Insufficient NPSH. Suction lift too high. Check gauges. Also check for clogged suction line or screen.
5. Impeller partially plugged.
6. Mechanical defects.
  - a. Worn wear rings
  - b. Impeller damaged.
  - c. Incorrect direction of rotation.

### C. Insufficient Discharge Pressure

1. Speed too low.
2. System head less than anticipated.
3. Air in system.
4. Mechanical defects.
  - a. Worn wear rings.
  - b. Impeller damaged.
  - c. Impeller diameter too small.
  - d. Incorrect direction of rotation.

### D. Loss of Suction

1. Leak in suction line.
2. Suction lift too high.

3. Insufficient NPSH.

4. Air in system.
5. Casing gasket defective.

### E. Excessive Power Consumption

1. Speed too high.
2. System head lower than rating.
3. Specific gravity of liquid too high.
4. Mechanical defects.
  - a. Shaft bent.
  - b. Rotating elements bind.
  - c. Worn wear ring.

### F. Vibration

1. Air leak in suction line.
2. Air in system.
3. Impeller partially plugged.
4. Foundation not rigid.
5. Mechanical defects.
  - a. Damaged impeller.
  - b. Motor bearings worn.
  - c. Rotor out of balance.
  - d. Shaft bent.

### G. Motor Runs Hot

1. Speed too high.
2. Specific gravity of liquid too high.
3. Mechanical defects.
  - a. Shaft bent.
  - b. Rotating elements bind.
  - c. Defective motor.
  - d. Voltage lower than rating.

## LIMITED WARRANTY STATEMENT

Taco, Inc. will repair or replace without charge (at the company's option) any commercial pump product or part which is proven defective under normal use within one (1) year from the date of start-up or one (1) year and six (6) months from date of shipment (whichever occurs first).

Motors provided on commercial pumps are not covered by this warranty, and are warranted by the motor manufacturer. For complete details on motor warranty returns, the purchaser should contact the motor manufacturer's local service repair center or contact the motor manufacturer directly.

Seals provided on commercial pumps are not covered by this warranty.

In order to obtain service under this warranty, it is the responsibility of the purchaser to promptly notify the local Taco stocking distributor or Taco in writing and promptly deliver the subject product or part, delivery prepaid, to the stocking distributor. For assistance on warranty returns, the purchaser may either contact the local Taco stocking distributor or Taco. If the subject product or part contains no defect as covered in this warranty, the purchaser will be billed for parts

and labor charges in effect at time of factory examination and repair.

Any Taco product or part not installed or operated in conformity with Taco instructions or which has been subject to misuse, misapplication, the addition of petroleum-based fluids or certain chemical additives to the systems, or other abuse, will not be covered by this warranty.

If in doubt as to whether a particular substance is suitable for use with a Taco product or part, or for any application restrictions, consult the applicable Taco instruction sheets or contact Taco at [401-942-8000].

Taco reserves the right to provide replacement products and parts which are substantially similar in design and functionally equivalent to the defective product or part. Taco reserves the right to make changes in details of design, construction, or arrangement of materials of its products without notification.

**TACO OFFERS THIS WARRANTY IN LIEU OF ALL OTHER EXPRESS WARRANTIES. ANY WARRANTY IMPLIED BY LAW INCLUDING**

**WARRANTIES OF MERCHANTABILITY OR FITNESS IS IN EFFECT ONLY FOR THE DURATION OF THE EXPRESS WARRANTY SET FORTH IN THE FIRST PARAGRAPH ABOVE.**

**THE ABOVE WARRANTIES ARE IN LIEU OF ALL OTHER WARRANTIES, EXPRESS OR STATUTORY, OR ANY OTHER WARRANTY OBLIGATION ON THE PART OF TACO.**

**TACO WILL NOT BE LIABLE FOR ANY SPECIAL, INCIDENTAL, INDIRECT OR CONSEQUENTIAL DAMAGES RESULTING FROM THE USE OF ITS PRODUCTS OR ANY INCIDENTAL COSTS OF REMOVING OR REPLACING DEFECTIVE PRODUCTS.**

This warranty gives the purchaser specific rights, and the purchaser may have other rights which vary from state to state. Some states do not allow limitations on how long an implied warranty lasts or on the exclusion of incidental or consequential damages, so these limitations or exclusions may not apply to you.

 **Taco Comfort Solutions**® A Taco Family Company

Taco, Inc., 1160 Cranston Street, Cranston, RI 02920 | Tel: (401) 942-8000 | FAX: (401) 942-2360

Taco (Canada), Ltd., 8450 Lawson Road, Suite #3, Milton, Ontario L9T 0J8 | Tel: (905) 564-9422 | FAX: (905) 564-9436

Visit our web site: [www.TacoComfort.com](http://www.TacoComfort.com) | Printed in USA | ©2019 Taco, Inc.

