



KS Series Pump | Submittal Data

Vertical Split Coupled Pumps

Submittal No: 301-17191 | Model: 1213B | RPM: 1450 - 50 Hz | Effective: June 1, 2026 | Supersedes: December 22, 2022

JOB: _____

REPRESENTATIVE: _____

ENGINEER: _____

CONTRACTOR: _____

PRODUCT DATA

ITEM NO. _____ MODEL NO. 1213B

IMPELLER DIAMETER _____ HORSEPOWER _____

GPM _____ VOLTAGE _____

HEAD/FT _____ RPM 1450

WEIGHT _____ PUMP/MOTOR _____

SUPPORT STAND OPTION YES NO

(Ductile Iron ASTM A536-84 Grade 65-45-12)

DIMENSIONS

Model No. | 1213B

Flange Size (Suction x Discharge) | 12 x 12 (305 x 305)

HORSEPOWER	40	50	60	75	100	125	150	200	
MOTOR FRAME	TEFC	324CZ	326CZ	364CZ	365CZ	405CZ	444TC	445TC	447TC
	ODP	324CZ	326CZ	364CZ	365CZ	404CZ	405CZ	444TC	445TC
WEIGHT WITHOUT OPTIONAL STAND LBS (KG)	3009 (1365)		3335 (1513)		3706 (1681)		4348 (1972)		5321 (2414)
WEIGHT WITH OPTIONAL STAND LBS (KG)	3320 (1506)		3646 (1654)		4017 (1822)		4659 (2113)		5662 (2568)
FLANGE SIZE ASA	12 (305)								
A*	ANSI CLASS 125: 30.25 (768)								
	ANSI CLASS 250: 31.00 (787)								
B*	ANSI CLASS 125: 24.25 (616)								
	ANSI CLASS 250: 25.00 (635)								
C	18.87 (479)								
D	51.26 (1302)				55.21 (1402)				
E MAX	31.07 (789)	32.57 (827)	34.40 (874)	35.29 (896)	38.53 (979)		43.49 (1104)		52.50 (1333)
F	11.24 (285)								
G	16.66 (423)								
J DIA MAX	17.35 (441)		19.25 (489)		21.42 (544)		24.56 (624)		
K MAX	14.12 (359)		14.97 (380)		18.65 (474)		20.75 (527)		21.71 (551)
L	30.78 (782)		31.63 (803)		35.31 (897)		37.41 (950)		
M	16.61 (422)								
N	8.00 (203)								
P	28.00 (711)								
Q	1.13 (29)								
R	24.00 (610)								
S	4								
T	5/8-11 UNC-2B								

OPERATING SPECIFICATIONS

FLANGE	PRESSURE	TEMPERATURE
ANSI Class 125	175 PSIG* (1210 KPA)	250°F (120°C)
ANSI Class 250	300 PSIG** (2070 KPA)	250°F (120°C)

Motors: All NEMA Standard (CZ or TC Frame)

* In accordance with ANSI Standard B16.1 Class 125

** In accordance with ANSI Standard B16.1 Class 250

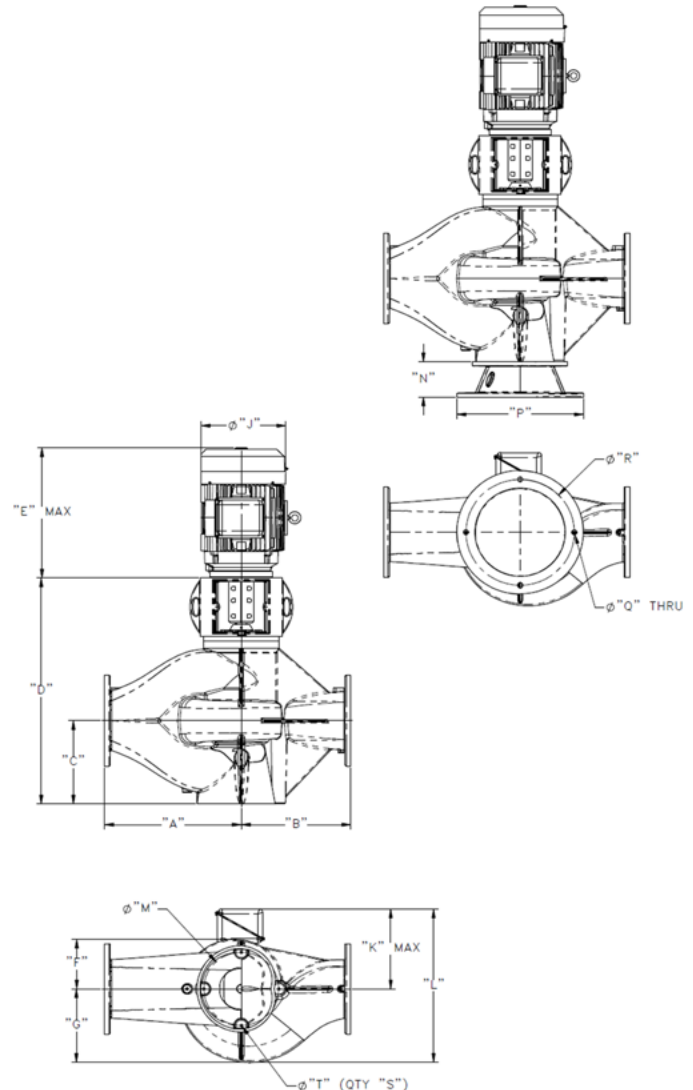

*A & B Dimensions apply for all pump sizes.

English dimensions are in inches. Metric dimensions are in millimeters. Metric data is presented in (). Do not use for construction purposes unless certified.

MATERIALS OF CONSTRUCTION

	BRONZE FITTED		
	STANDARD PUMP CONSTRUCTION		OPTIONAL
	125# Flange	250# Flange	125# or 250#
Casing	Cast Iron ASTM A48/ A48M-03 Class 30A	Ductile Iron ASTM A536-84 Grade 65-45-12	N/A
Impeller	Bronze ASTM B584 ALLOY C83600 or C84400	Bronze ASTM B584 ALLOY C83600 or C84400	N/A
Wear Ring	Cast Iron	Cast Iron	Bronze ASTM B584-98A C92200
Shaft	Stainless Steel TYPE 416"™" or 410"™" ASTM A582	Stainless Steel TYPE 416"™" or 410"™" ASTM A582	N/A
Coupling	Aluminum Alloy 6061-T6	Aluminum Alloy 6061-T6	N/A
Mechanical Seal	Ceramic/EPT	Ceramic/EPT	Tungsten Carbide/EPT or Silicon- Carbide/EPT
Seal Flush Line	Copper & Brass C3600	Copper & Brass C3600	N/A

N/A = Not available

Revised: 05/31/2017

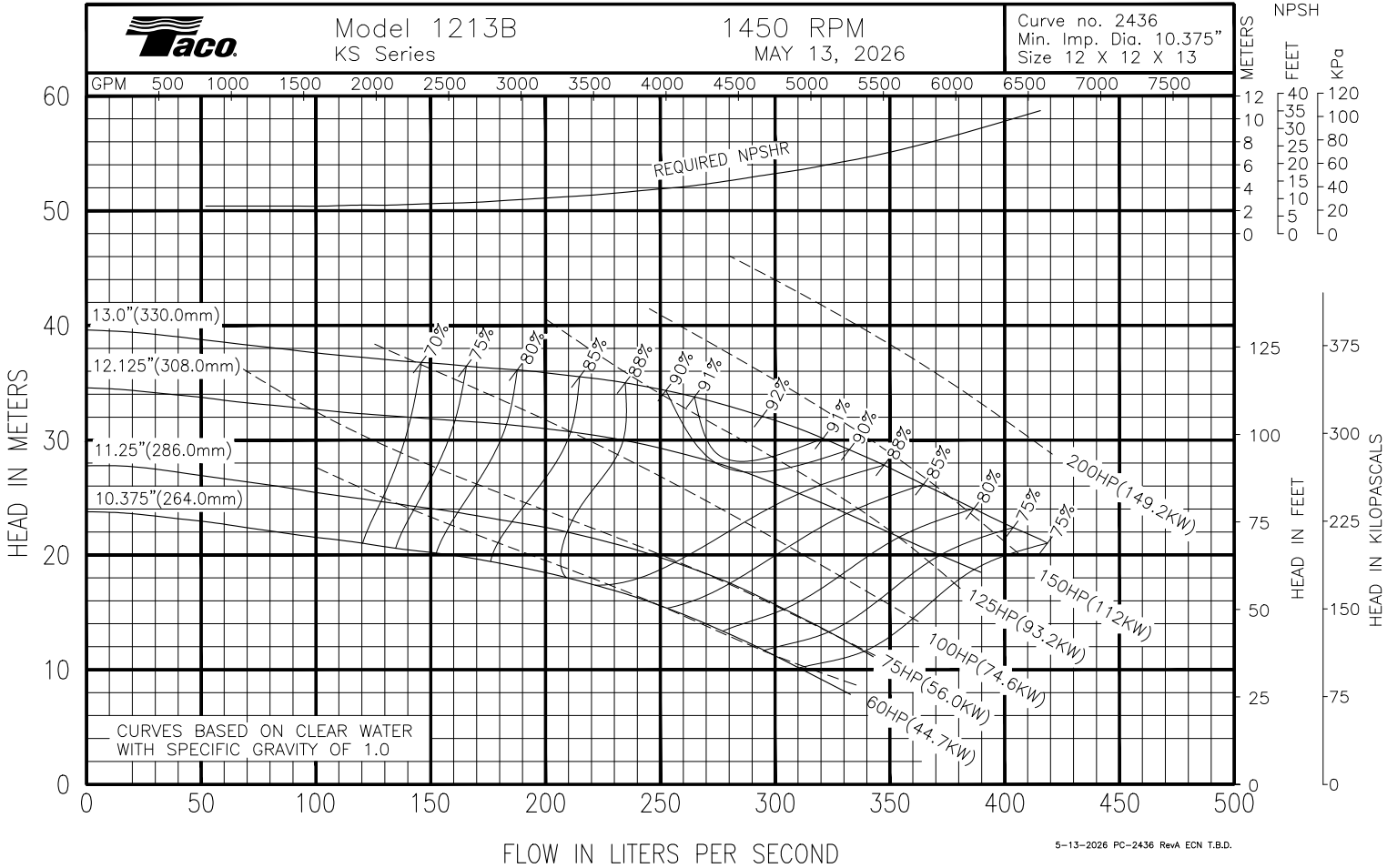

COMMENTS