

Taco Booster Submittal Information

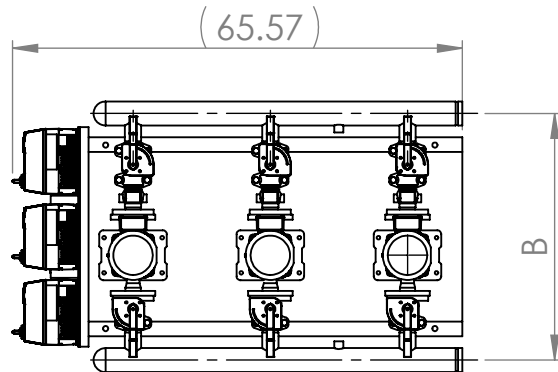
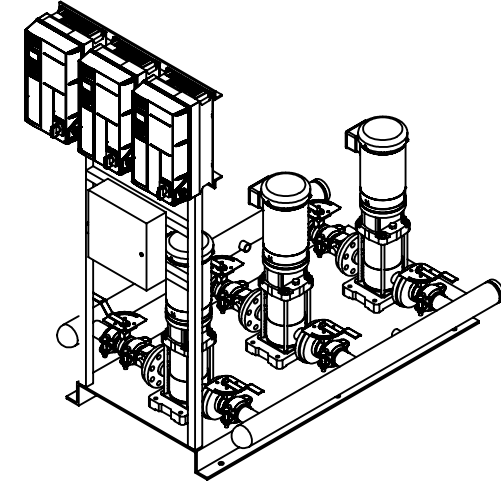
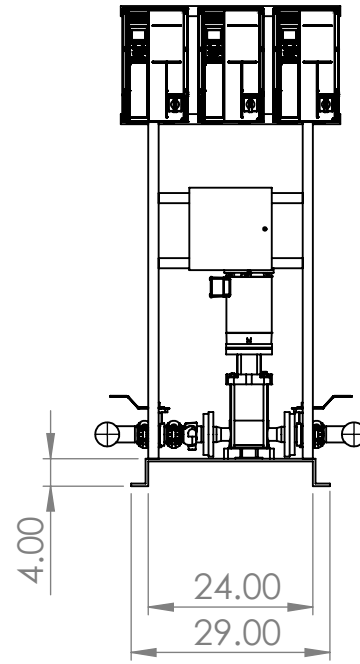
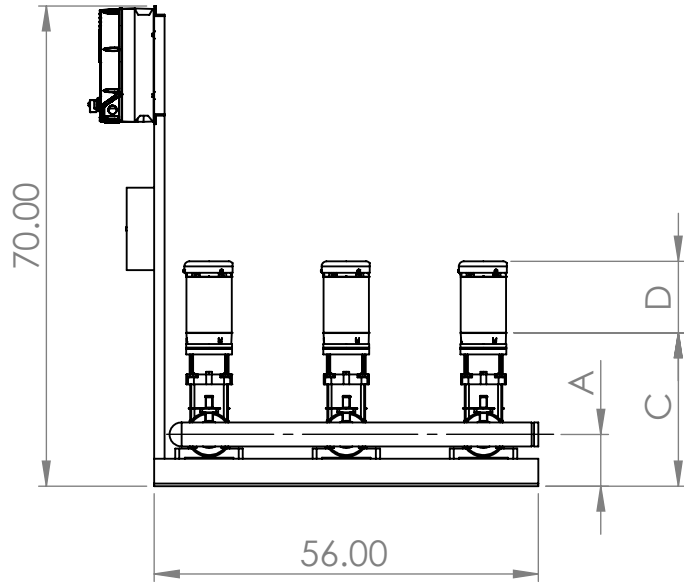

Pump Model	Header Dia.	A	B		Cmin	Cmax	Dmin	Dmax
			150#	300#				
1VR	2	7.0	33.4	35.3	12.3	33.5	11.1	11.1
3VR					31.7	13.1		
6VR					12.6	41.8		16.1
1VR	3	7.0	36.4	38.3	12.3	33.5	11.1	11.1
3VR					31.7	13.1		
6VR					12.6	41.8		16.1
10VR	2	7.5	27.7	32.9	13.7	29.9	11.1	20.9
15VR					16.3	43.8		19.8
20VR					13.7	29.9		20.9
10VR	3/4	7.5	28.2	33.4	13.7	29.9	11.1	20.9
15VR					16.3	43.8		19.8
20VR					13.7	29.9		20.9
10VR	6	7.5	30.3	35.5	13.7	29.9	11.1	20.9
15VR					16.3	43.8		19.8
20VR					13.7	29.9		20.9
30VR	-	8.1	39.2	41.8	17.9	48.9	13.7	25.0
45VR	-	8.1	39.2	41.8	17.9	48.9	13.7	25.0
45VR	-	9.5	46.1	42.7	26.7	47.0	15.2	27.6
65VR	-	9.5	46.1	42.7	26.7	47.0	15.2	27.6
95VR	-	9.5	46.6	43.2	29.0	44.5	17.9	27.6

Booster Info Section	
Project:	
Rep.:	
Model:	
Pump Details:	
Total Package Flow (USGPM):	
Total Package Head (ft):	
Sequence of Operation:	
Header Size:	
Motor Enclosure:	
Motor Electrics:	
Integrated Drive Controller Enclosure: UL type	
UL/CSA Labelled	
Dual DC-Link chokes (5% AC line reactor)	
Protocols (Standard): BACnet, Modbus RTU, N2 Metasys, FLN Apogee, FC Protocol	

NOTES:

1. Not to be used for construction/piping unless certified
2. Control Panel arrangement/design may vary
3. Dimensions are approx.
4. Maximum operating pressure is

Drafter Remarks:

MODIFICATION	REV	DATE	DRW BY

Model:			
DRW BY:	DATE:	CHKD BY:	DATE:
J.D	2/10/2026	N/A	N/A
TOLERANCES UNLESS OTHERWISE SPECIFIED			
Dec: ±0.06	Frac: ±1/16	Angle: ±1/2°	SCALE: NTS
REV	SIZE	TAG:	
C	A4		

	Taco Canada LTD. 8450 Lawson road Unit 3 Milton, ON, L9T0J8
	<small>THIS DRAWING AND THE INFORMATION DEPICTED THEREIN IS THE PROPERTY OF TACO CANADA. COPIES ARE ISSUED IN STRICT CONFIDENCE AND SHALL NOT BE REPRODUCED, OR COPIED OR USED AS THE BASIS FOR THE MANUFACTURE OR SALE OF PRODUCTS WITHOUT PRIOR WRITTEN PERMISSION OF TACO CANADA.</small>
SHEET 1 OF 1	WEIGHT: