

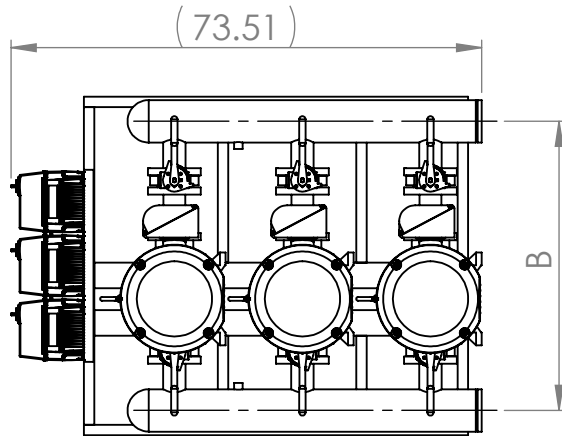

Taco Booster Submittal Information

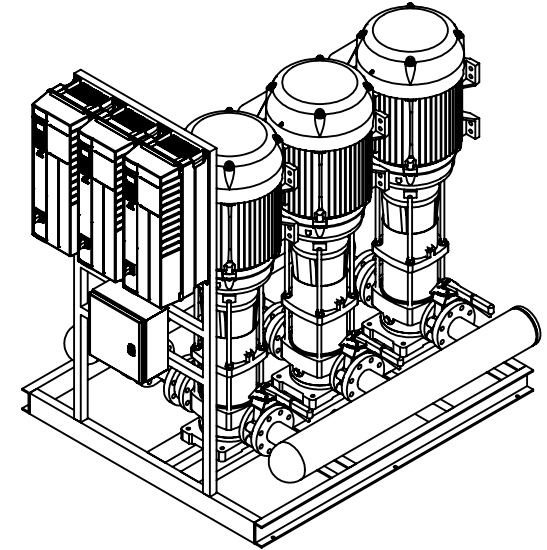
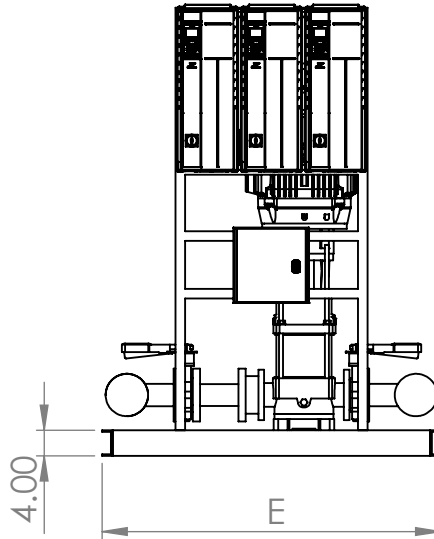
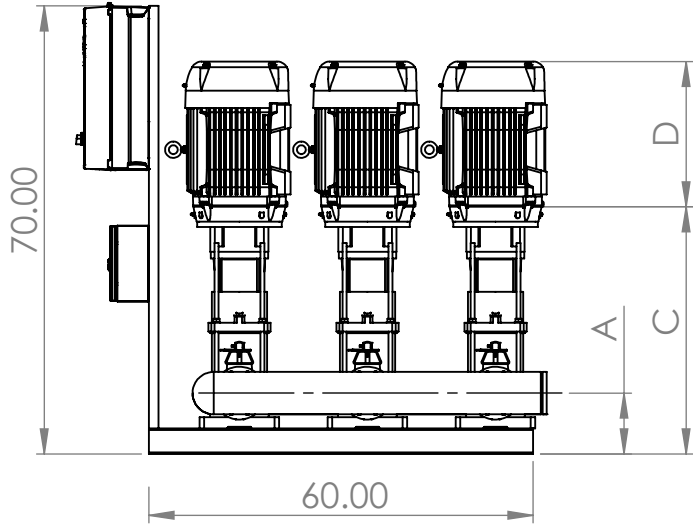

Pump Model	Header Dia.	A	B		Cmin	Cmax	Dmin	Dmax	E	
			150#	300#					150#	300#
1VR	2	7	33.4	35.3	12.3	33.5	11.1	11.1	53.6	55.1
3VR					31.7	13.1				
6VR					41.8	16.1				
1VR	3	7	36.4	38.3	12.3	33.5	11.1	11.1	53.6	55.1
3VR					31.7	13.1				
6VR					41.8	16.1				
10VR	2	7.5	27.7	32.9	16.3	43.8	11.1	20.9	47.1	53.6
15VR					40	19.8				
20VR					13.7	29.9				
10VR	3/4	7.5	28.2	33.4	16.3	43.8	11.1	20.9	47.1	53.6
15VR					40	19.8				
20VR					13.7	29.9				
10VR	6	9.5	30.3	35.5	16.3	43.8	11.1	20.9	63.1	65.6
15VR					40	19.8				
20VR					13.7	29.9				
30VR	-	8.1	39.2	41.8	17.9	48.9	13.7	25	57.6	60.1
45VR	-	-	42.2	26.7	47	-	15.2	-	-	60.6
65VR	-	9.5	40	42.7	29	44.5	-	27.6	63.1	65.6
95VR	-	-	40.5	43.2	29	40.9	17.9	-	-	-

Booster Info Section	
Project:	
Rep.:	
Model:	
Pump Details:	
Total Package Flow (USGPM):	
Total Package Head (ft):	
Sequence of Operation:	
Header Size:	
Motor Enclosure:	
Motor Electrics:	
Integrated Drive Controller Enclosure: UL type	
UL/CSA Labelled	
Dual DC-Link chokes (5% AC line reactor)	
Protocols (Standard): BACnet, Modbus RTU, N2 Metasys, FLN Apogee, FC Protocol	

NOTES:

1. Not to be used for construction/piping unless certified
2. Control Panel arrangement/design may vary
3. Dimensions are approx.
4. Maximum operating pressure is

Drafter Remarks:

MODIFICATION	REV	DATE	DRW BY

Model:	
DRW BY:	J.D
DATE:	2/10/2026
CHKD BY:	N/A
DATE:	N/A
TOLERANCES UNLESS OTHER SPECIFIED	
Dec: ±0.06	Ang: ±1/2
REV	C
SIZE	A4
TAG:	

Taco Canada LTD.
 8450 Lawson road Unit 3
 Milton, ON,
 L9T0J8

THIS DRAWING AND THE INFORMATION DEPICTED THEREIN IS THE PROPERTY OF TACO CANADA. COPIES ARE ISSUED IN STRICT CONFIDENCE AND SHALL NOT BE REPRODUCED, OR COPIED OR USED AS THE BASIS FOR THE MANUFACTURE OR SALE OF PRODUCTS WITHOUT PRIOR WRITTEN PERMISSION OF TACO CANADA.

SHEET 1 OF 1

WEIGHT: