

Taco Booster Submittal Information

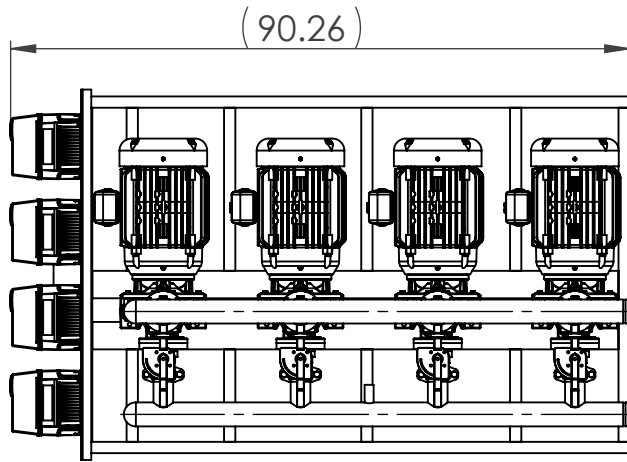
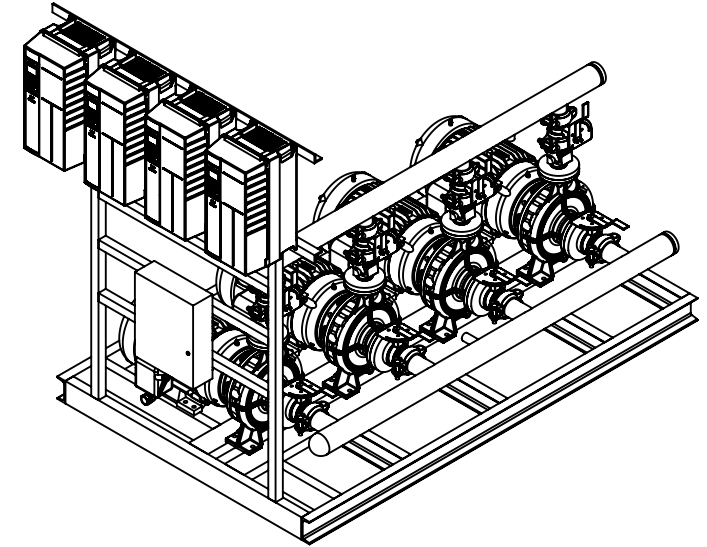
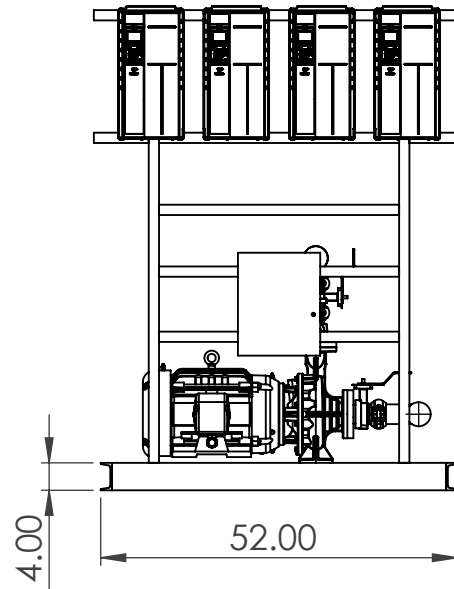
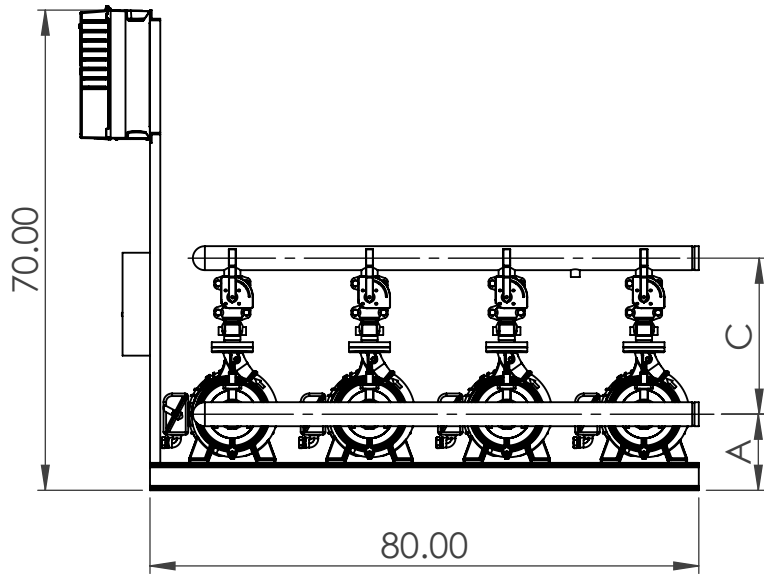

| Pump Model | A | B | | C | |
|------------|------|------|------|-------|------|
| | | 150# | 300# | 150 # | 300# |
| CI1206 | 9.2 | 11.7 | 11.9 | 20.6 | 20.9 |
| CI1207 | 10.3 | 11.7 | 11.9 | 21.6 | 21.9 |
| CI1209 | 11.1 | 15.4 | 15.7 | 23.5 | 23.7 |
| CI1506 | 9.2 | 14.6 | 14.9 | 21.8 | 22.0 |
| CI1507 | 10.3 | 14.3 | 14.6 | 21.3 | 21.5 |
| CI1509 | 11.1 | 14.6 | 14.9 | 23.5 | 23.8 |
| CI2007 | 10.3 | 15.1 | 15.4 | 18.2 | 18.5 |
| CI2009 | 11.1 | 15.0 | 15.3 | 20.2 | 20.5 |
| CI2506 | 10.3 | 13.0 | 13.4 | 21.5 | 21.8 |
| CI2507 | 11.1 | 13.9 | 14.2 | 21.1 | 21.4 |

| Booster Info Section | |
|---|--|
| Project: | |
| Rep.: | |
| Model: | |
| Pump Details: | |
| Total Package Flow (USGPM) | |
| Total Package Head (ft): | |
| Sequence of Operation: | |
| Header Size: | |
| Motor Enclosure: | |
| Motor Electrics: | |
| Integrated Drive Controller Enclosure: UL type | |
| UL/CSA Labelled | |
| Dual DC-link chokes (5% AC line reactor) | |
| Protocols (Standard): BacNet, Modbus RTU, N2 Metasys, FLN Apogee, FC Protocol | |

NOTES:

1. Not to be used for construction/piping unless certified
2. Control Panel arrangement/design may vary
3. Dimensions are approx.
4. Maximum operating pressure is

Drafter Remarks:

| MODIFICATION | REV | DATE | DRW BY |
|--------------|-----|------|--------|
| | | | |

| | | | |
|-----------------------------------|-------------|-------------|------------|
| Model: | | | |
| DRW BY: | DATE: | CHKD BY: | DATE: |
| WT | 08/18/2022 | N/A | N/A |
| TOLERANCES UNLESS OTHER SPECIFIED | | | |
| Dec: ±0.06 | Frac: ±1/16 | Angle: ±1/2 | SCALE: NTS |
| REV | SIZE | TAG: | |
| A | A4 | | |



Taco Canada LTD.
8450 Lawson road Unit 3
Milton, ON,
L9T0J8

THIS DRAWING AND THE INFORMATION DEPICTED THEREIN IS THE PROPERTY OF TACO CANADA. COPIES ARE ISSUED IN STRICT CONFIDENCE AND SHALL NOT BE REPRODUCED, OR COPIED OR USED AS THE BASIS FOR THE MANUFACTURE OR SALE OF PRODUCTS WITHOUT PRIOR WRITTEN PERMISSION OF TACO CANADA.

SHEET 1 OF 1 WEIGHT: