



# Submittal Data Information

## PAX Expansion Tanks

(Certified by NSF to NSF/ANSI 61-G for Potable Water Applications)

401-084P

SUPERSEDES: December 1, 2014

EFFECTIVE: July 25, 2018

JOB \_\_\_\_\_ ENGINEER \_\_\_\_\_ CONTRACTOR \_\_\_\_\_ REP. \_\_\_\_\_

ITEM NO.	LOCATION	MODEL NO.	QUANTITY	PRE-CHARGE *	WORKING PRESSURE **

\* Unless otherwise specified, standard pre-charge of 40 psi (276 kPa).

**SPECIFICATIONS**

- Designed and constructed per ASME Code Section VIII, Div. 1.
- Construction: Carbon Steel with exterior red oxide primer finish
- Standard Design Pressure and Temperature: 150 psi @ 240°F (136 kPa @ 116°C) Max.
- Registered with the National Board of Pressure Vessel Manufacturers
- U-1A Data Report
- Bladder type for permanent separation of air and water.
- Water expands into bladder, air pre-charge on shell side.
- Bladder – Heavy Duty Butyl, removable for inspection.
- System Connection Materials 304 Stainless Steel
- **For VERTICAL Installation ONLY**
- Models certified to NSF/ANSI 61-G are required to be installed on the cold water side of the hot water heater.

• **Optional Design Pressures and Temperatures**

- 175 psi @ 240°F (1207 kPa @ 116°C)

• **Additional Options**

- [ A ] Anchor Clips
- [ B ] Bulls Eye Sight Glass

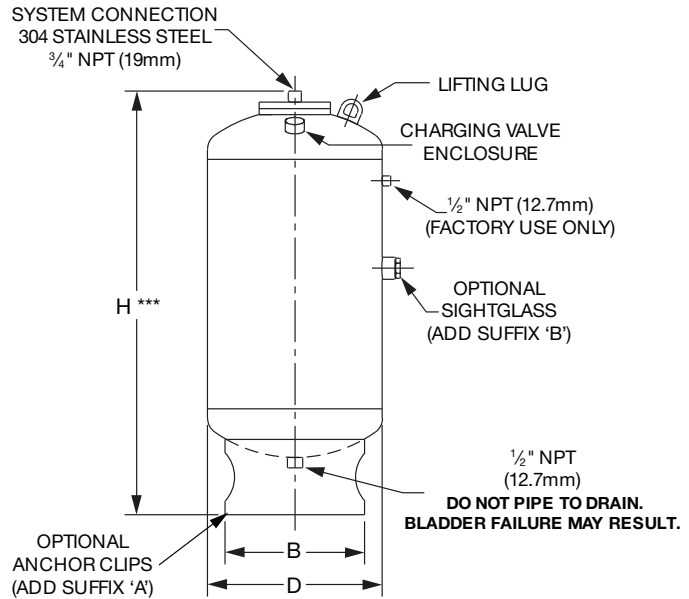

MODEL NUMBER	TANK VOLUME		ACCEPTANCE VOLUME		H HEIGHT ***		B DIAMETER		D DIAMETER		SHIPPING WEIGHT **		SYSTEM CONNECTION SIZE	
	GAL.	liter	GAL.	liter	INCH	mm	INCH	mm	INCH	mm	LBS.	kg	Imperial	metric
PAX30-150P	8	30	5	19	24 <sup>3</sup> / <sub>4</sub>	629	12	305	14	356	90	41	3/4" NPT	19 mm
PAX42-150P	11	42	5	19	29 <sup>3</sup> / <sub>4</sub>	756	12	305	14	356	105	48	3/4" NPT	19 mm
PAX84-150P	22	83	12	45	41 <sup>1</sup> / <sub>4</sub>	1048	12	305	16	406	150	68	3/4" NPT	19 mm
PAX130-150P	34	129	19	72	52 <sup>1</sup> / <sub>2</sub>	1334	12	305	16	406	200	91	3/4" NPT	19 mm
PAX170-150P	45	170	24	91	65 <sup>3</sup> / <sub>4</sub>	1670	12	305	16	406	240	109	3/4" NPT	19 mm
PAX215-150P	57	216	31	117	57 <sup>7</sup> / <sub>8</sub>	1470	16	406	20	508	250	113	3/4" NPT	19 mm
PAX254-150P	67	254	34	129	67 <sup>1</sup> / <sub>4</sub>	1708	16	406	20	508	280	127	3/4" NPT	19 mm
PAX300-150P	79	299	43	163	56 <sup>1</sup> / <sub>2</sub>	1435	20	508	24	610	300	136	3/4" NPT	19 mm
PAX350-150P	92	348	43	163	63 <sup>5</sup> / <sub>8</sub>	1616	20	508	24	610	330	150	3/4" NPT	19 mm
PAX425-150P	112	424	61	231	76 <sup>3</sup> / <sub>8</sub>	1940	20	508	24	610	380	172	3/4" NPT	19 mm
PAX500-150P	132	500	61	231	84 <sup>7</sup> / <sub>8</sub>	2156	20	508	24	610	425	193	3/4" NPT	19 mm

\*\* Weight shown is for 150 psi models only. Consult factory for shipping weight of higher design pressure models.\*\*

\*\*\* Allow 18" minimum clearance above tank for piping system connection.

COMMENTS: \_\_\_\_\_