

Installation, Operation, and Maintenance Manual

SUPERSEDES: January 15, 2014

EFFECTIVE: June 5, 2018

Plant ID: 001-4209

Table of Contents

1 SAFETY REQUIREMENTS.....	2	11 START-UP PROCEDURE	37
2 GENERAL INSTALLATION REQUIREMENTS.....	2	11.1 Check Points Before First Start	37
2.1 Receiving Pump.....	2	11.2 Check Motor Rotation	37
2.2 Location	2	11.3 Start Pump.....	37
2.3 Foundation.....	2	11.4 Verify Flow.....	38
3 MAINTENANCE	2	12 SYSTEM BALANCING	39
3.1 Routine Inspections	2	12.1 About SelfSensing ProBalance	39
3.2 Close Coupled Pumps	3	12.2 My Personal Menu for ProBalance	40
3.3 Close Coupled Motors	3	12.3 Balancing Procedure	41
3.4 Mechanical Seal.....	3	12.4 Additional Settings.....	49
4 DIS-ASSEMBLY AND RE-ASSEMBLY.....	3	13 MENUS.....	50
4.1 General	3	14 WARNINGS AND ALARMS	61
4.2 Dis-Assembly	3	14.1 Supplemental Warning and Alarm Settings ..	70
4.3 Re-Assembly	3	15 CASING/IMPELLER WEAR RING CLEARANCES	73
5 PUMP PIPING - GENERAL.....	4	16 SKS PUMP PROBLEM ANALYSIS	74
6 APPLICATION.....	4	17 SPECIFICATIONS	75
7 MECHANICAL INSTALLATION	4	17.1 Power-dependent Specifications.....	75
7.1 Location	4	17.2 Connection Tightening Torques.....	77
7.2 VFD Mounting to Pump	4	A SET-UP FOR STANDBY PUMP ALTERNATION .	78
7.3 VFD Mounting to Wall	6	B ON-SITE DRIVE MOUNTING TO WALL OR PUMP	83
7.4 Pump Piping – Detailed	6		
8 ELECTRICAL CONNECTIONS.....	9		
8.1 Exploded Views	9		
8.2 Electrical Installation	10		
8.3 Grounding Requirements.....	12		
8.4 Typical Terminal Wiring Configurations	18		
9 USER INTERFACE.....	28		
9.1 Local Control Panel	28		
9.2 Backup and Copying Parameter Settings	30		
9.3 Password Protection	31		
10 PUMP CONTROL SET-UPS.....	34		
10.1 SelfSensing Description.....	34		
10.2 Set-up Menu	34		
10.3 Variable Flow Control (Flow Compensation) ..	35		
10.4 Constant Flow Control	35		
10.5 Constant Pressure Control.....	36		
10.6 Sequencing (Standby Pump Alternation)	36		



1 SAFETY REQUIREMENTS



CAUTION: These instructions should be read completely prior to installation of the equipment. A copy of these instructions should be retained on file for future reference.



WARNING: Electrical shock hazard. Disconnect **ALL** power sources when installing or servicing this equipment to prevent electrical shock or equipment damage.

This pump is intended for the circulation of water or other suitable HVAC media. It is not intended for hazardous, corrosive, or flammable liquids.

Pump must not be operated until all piping and/or electrical connections are in place.

Proper care and suitable equipment should be used to move and install this heavy equipment.

Care should be taken when installing pipe systems to avoid placing an excessive load on the pump unions.

Refer to motor installation instructions to determine proper terminal connections in order to obtain correct pump rotation.

When the system piping is used as an earth bonding path for the building electrical services (check local codes), the pump should not be relied upon as part of the circuit. A properly installed bridging connection should be provided.

If electrical connection is to be made using any means other than rigid conduit, proper strain relief must be provided (min 100N tension).

Pump should be installed according to local electrical and safety codes using appropriate size wire and suitable over current protection. It should use a lockable isolator or circuit breaker conforming to applicable electrical codes.

It is recommended that the pump be fitted with a suitable “emergency stop” per the requirements of applicable electrical codes.

2 GENERAL INSTALLATION REQUIREMENTS

2.1 Receiving Pump

Inspect for shipping damage. If a shortage or damage occurs, contact carrier immediately.

2.2 Location

Install vertically with motor up. Consult factory for horizontal mounting.

Pump should be accessible for inspection and repair work, head room must be provided for the use of hoist or tackle as necessary.

Lift pump by slinging through motor eye bolts and securing through pump adapter.

NOTE: In no case should any part of motor be covered with insulation.

2.3 Foundation

The pump must always be supported.

Pumps with smaller motors may be suspended in the piping, provided the piping is supported adjacent to the pump.

For pumps with larger motors, the pump should be attached to a support utilizing the tapped hole or holes in the bottom of the pump casing.

NOTE: Piping loads shall not be applied to the pump.

Pump must be allowed to move with piping movement. Expansion of piping must be taken into account when piping and suitable devices should be employed. Do not rigidly connect the pump to the floor.

NOTE: Provide vibration isolation pads under floor mounted supports. Do not support unit by the motor eye-bolts.

3 MAINTENANCE

3.1 Routine Inspections

Routine inspections should be made on a regular basis. Inspections made while pump is running should reveal potential failures.

- Inspect motor bearings for any sign of temperature rise. Temperature should not exceed 160°F. Temperature rise may indicate the early stages of bearing problems.
- Listen for any unusual noise:
 1. Air trapped in pump.
 2. Hydraulic noise.
 3. Mechanical noise in motor and/or pump.
- Check suction gauge reading and confirm that it is normal.

- Check discharge gauge reading and confirm that it is normal. If gauge readings are abnormal find out why.

NOTE: Suction and discharge gauges should read the same with pump stopped.

3.2 Close Coupled Pumps

The pump section is attached directly to the motor shaft and does not contain bearings.

3.3 Close Coupled Motors

The motor must be lubricated in accordance with the manufacturer's recommendations. Do not over lubricate the motor bearings as this could cause premature bearing failure.

3.4 Mechanical Seal

The mechanical seal is the "John Crane" Type 21 General Purpose Seal for the 175 psig pressure rating.

A "John Crane" Type 2 General Purpose Seal is used for the 300 psig pressure rating.

4 DIS-ASSEMBLY AND RE-ASSEMBLY

4.1 General

If the pump has been maintained and serviced properly, breakdowns requiring pump disassembly should occur only rarely.

- If a problem occurs, the cause should be determined, if possible, before dis-assembling. (See "Problem Analysis")
- If the pump is being dis-assembled, all parts must be carefully handled, avoid heavy blows and shocks.
- All parts must be carefully cleaned and inspected for wear. Recondition or replace parts where necessary.

4.2 Dis-Assembly

Drain liquid from casing by removing drain plug.



CAUTION: Allow pump to cool and secure suction and discharge valves before working on pump!

Remove re-circulation line.

Remove bolts holding cover/adaptor to casing, pry cover/adaptor and motor assembly from casing.

Remove impeller bolt in a counterclockwise direction. Remove impeller and key.

In all cases of mechanical seal arrangement, after removing the sleeve and its seal assembly, the seal rotating element may be drawn off the shaft sleeve.

NOTE: Apply silicone grease on the OD of the sleeve in the area between the seal and the end of the sleeve. This will help removal of the old seal. The stationary element is to be removed from the cover.

All parts must be cleaned and inspected for wear. Replace parts where necessary.

4.3 Re-Assembly

Be certain that all parts to be replaced are free from burrs, with screw threads and connecting faces clear and free from damage.

Insert stationary element of seal into cover adapter, slip cover-adaptor over shaft and engage rabbit of motor.

Note: Do not touch the seal surfaces because this may result in leakage. Do not contaminate seal faces with fingerprints.

Lubricate smaller OD of shaft sleeve with silicone grease. Do not use petroleum oil or grease.

Place spring on shaft sleeve to abut against sleeve shoulder. Slide rotary seal on sleeve until it contacts spring.

Slide the shaft sleeve on the shaft, larger bore first. Be certain the O-ring is correctly seated in the groove.

Assemble impeller key and impeller on shaft. Refit with new impeller washer on impeller bolt and tighten carefully. Be certain that the impeller rotates freely by hand.

Apply a few spots of gasket adhesive to gasket surface of cover. Place a new casing gasket against gasket surface and press against adhesive.

Assemble cover-adaptor complete with motor into casing. Insure that gasket is seated correctly. Install hex-headed cap screws into casing tapings and tighten uniformly.

Reconnect re-circulation line and drain plug.

5 PUMP PIPING - GENERAL



CAUTION: NEVER connect any pump to piping, unless extra care is taken to measure and align the piping flanges well. Always start piping from pump. Use as few bends as possible and preferably long radius elbows.

Do not use flexible connectors on the suction or discharge of a vertical in-line pump, unless the pump is rigidly mounted to a foundation. Ensure piping exerts no strain on pump as this could distort the casing causing breakage or early failure due to pump misalignment. All connecting pipe flanges must be square to the pipe work and parallel to the pump flanges.

Suction and discharge pipes may be increased or decreased at pump nozzle to suit pump capacity and particular conditions of installation. Use eccentric reducers on suction connection with flat side uppermost.

Lay out the suction line with a continual rise towards the pump without high points, thus eliminating possibility of air pockets that may prevent the pump from operating effectively.

6 APPLICATION

Working Pressure:	175 psig
Optional Working Pressure:	300 psig
Temperature:	250°F Standard 300°F Hi Temperature

7 MECHANICAL INSTALLATION

7.1 Location

In open systems, locate the unit as close as practical to the liquid supply source, with a short, direct suction pipe. Ensure adequate space is left above and around the unit for operation, maintenance, service and inspection of parts.

In closed systems, where possible, the pumps should be installed immediately downstream of the expansion tank/ make-up connection. This is the point of zero pressure change and is necessary for effective pump operation. Do not install more than one expansion tank connection into any closed hydronic system.

Electric motor driven pumps should not be located in damp or dusty location without special protection.

Airflow into the motor and/or motor fan should not be obstructed.

7.2 VFD Mounting to Pump

For instructions on mounting the VFD directly to the pump, see the diagrams and notes on the following page.

Figure 7-1: VFD Mounting to Pump

1. Items specified on this drawing are specifically for the SKV or SKS product series.
2. Assemble safety strap onto isolation mount stud to produce orientation shown in the assembly drawing.
3. Apply 'Loctite' to isolation mount stud threads (1 place) on all 4x parts.
4. Assemble threaded stud with 'Loctite' into bar bracket until surfaces are in contact without gaps.
5. Use strap wrench for isolation mounts. Screw mount into bar bracket (#2) until the rubber face is flush against the bar. Torque the mount 1/4 of a full turn.
6. Support VFD & assemble onto 4 isolation mounts simultaneously, assemble lockwashers & nuts, torque to specifications "C", remove VFD support.
7. Assemble the motor so the feet are angled between 22.5° to 45° offset from the flanges, as shown below.
8. Assemble the motor so the VFD and motor conduit box are hanging over the outlet volute.
9. * = all "D" bolt connections are SAE J429 grade #2 steel - nickel plated.

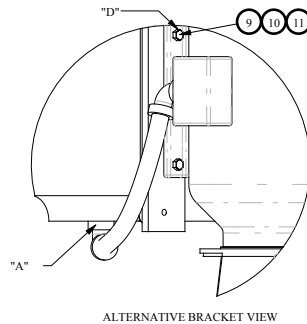
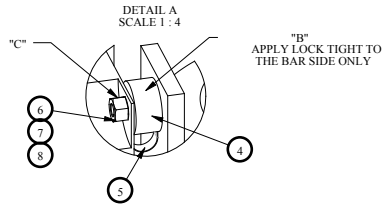
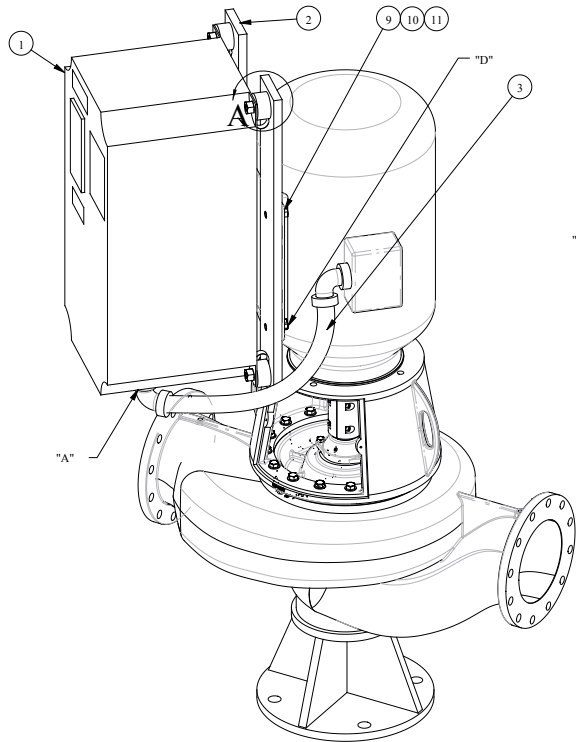

TORQUE REQUIREMENTS				
ALL TORQUE VALUES ARE +/- 15%				
SIZE	"A" MOTOR POWER WIRES TO VFD (In-lbs / Nm)	"B" VIBRATION MOUNT TO BAR BRACKET (In-lbs / Nm)	VIBRATION MOUNT THREAD SIZE	"C" VFD NUT TO VIBRATION MOUNT (Ft-lbs / Nm)
A5	5 / 0.6	SEE NOTE #7	M6 X 1	4.3 / 5.8
B1	16 / 1.8		M8 X 1.25	11.3 / 15.3
B2	40 / 4.5		M8 X 1.25	11.3 / 15.3
C1	89 / 10		M8 X 1.25	11.3 / 15.3
C2	124 / 14		M8 X 1.25	11.3 / 15.3
			M8 X 1.25	11.3 / 15.3

TORQUE REQUIREMENTS		
ALL TORQUE VALUES ARE +/- 15%		
MOTOR SIZE	BOLT SIZE	"D" MOTOR BOLT TO BAR BRACKET (FT-LBS / NM)*
143-145	5/16 X 18	11.5 / 15.6
182-215	3/8 X 16	20 / 27
254-286	1/2 X 13	49 / 66
324-365	5/8 X 11	98 / 133
404-449	3/4 X 10	173 / 235

SKV or SKS BOM Assembly		
ITEM #	DESCRIPTION	QTY
1	VFD	1
2	BAR BRACKET	2
3	WIRE HARNESS - MOTOR POWER	1
4	VIBRATION ISOLATION MOUNT	4
5	SAFETY STRAP	4
6	NUT (VFD)	4
7	LOCK WASHER (VFD)	4
8	WASHER (VFD)	4
9	SCREW (MOTOR)	4
10	LOCK WASHER (MOTOR)	4
11	WASHER (MOTOR)	4
N/A	"LOCTITE" (242; P/N 24231)	N/A

7.3 VFD Mounting to Wall

7.3.1 Lifting

- Check the weight of the unit to determine a safe lifting method.
- Ensure that the lifting device is suitable for the task.
- If necessary, plan for a hoist, crane, or forklift with the appropriate rating to move the unit.
- For lifting, use hoist rings on the unit, when provided.

7.3.2 Mounting

- Mount the unit vertically.
- The frequency converter allows side by side installation.
- Ensure that the strength of the mounting location will support the unit weight.
- Mount the unit to a solid flat surface or to the optional back plate to provide cooling airflow (see Figure 7-2 and Figure 7-3).
- Improper mounting can result in overheating and reduced performance.
- Use the slotted mounting holes on the unit for wall mounting, when provided.

Figure 7-2: Proper Mounting with Back Plate

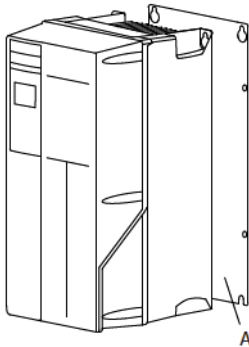

Item A is a back plate properly installed for required airflow to cool the unit.

Figure 7-3: Proper Mounting with Railings

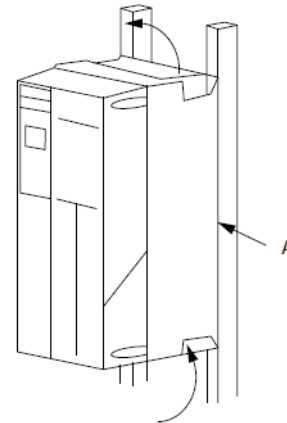

NOTE: Back plate is required when mounted on railings.

7.3.3 Tightening Torques

See “17.2 Connection Tightening Torques” on page 77 for proper tightening specifications.

7.4 Pump Piping – Detailed

In order to achieve the full added value of the Vertical In-Line pump design, it is important that you ensure the pump is affixed to the system piping by the pump flanges and the pump and motor assembly is allowed to float freely with the expansion and contraction of the piping system. Should any vertical in-line pump use supports to the structure, it is imperative that no pipe strain is imposed on the pump flanges. Compliant mounts such as springs or “waffle”-style isolation pads should be used under the pipe supports if the pump is not truly pipe mounted.

Various installation arrangements are detailed in the figures that follow.

Figure 7-4: Hanger Supported, Pipe Mounted

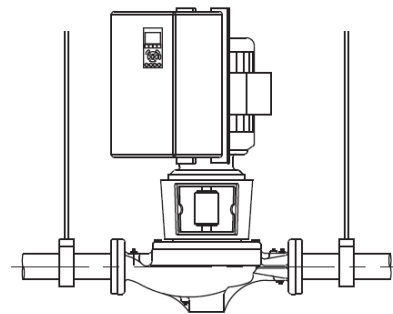

Vertical In-Line pumps may be installed directly in the system piping with no additional support. Pipe hangers are simply sized for the additional weight of the pumping unit. Many pumps are installed in this manner and are mounted at sufficient height to take zero floor space. (Figure 7-4)

Piping for smaller in-line pumps (typically 15 hp and below) is hung close to the ceiling in many mechanical rooms. Larger pumps are often mounted near ground level for ease of maintenance. Figure 7-5 illustrates such an arrangement with the piping supported at the ceiling and the vertical pump installed with a Taco Suction Diffuser (RSP) and Plus Two Multi-Purpose Valve.

Figure 7-5: Pipe Mounted, Supported at Ceiling

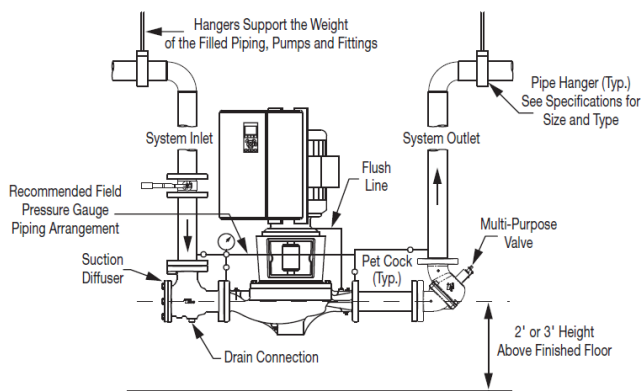

Should additional space saving be required, the discharge spool piece and Plus Two Multi-Purpose Valve may be replaced by a long-radius elbow and the Plus Two Multi-Purpose Valve field converted to a straight pattern configuration and installed in the vertical discharge pipe (Figure 7-6).

Figure 7-6: Discharge Elbow for Minimum Footprint

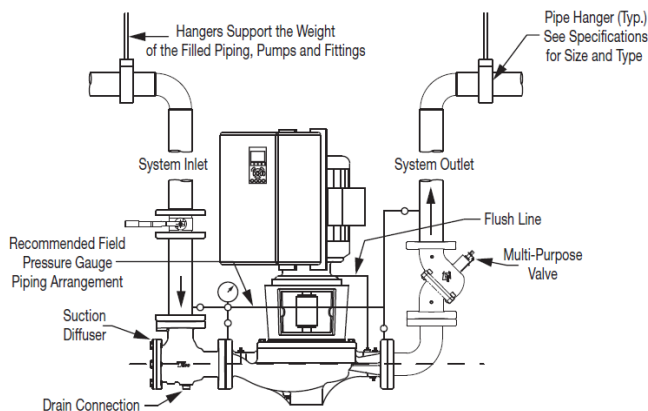

A similar arrangement to Figure 7-5 with additional floor mounted pipe-stools isolated from the structure by 'waffle' style isolation pads under the Suction Diffuser (RSP) and Plus Two Multi-Purpose Valve is illustrated in (Figure 7-7).

Figure 7-7: With Additional Pipe Supports

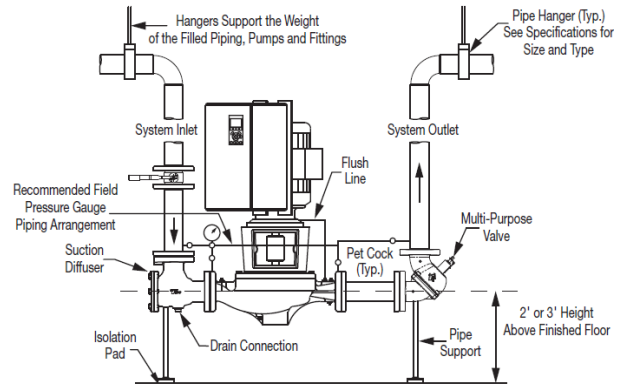

Floor mounted saddle supports (Figure 7-8) are typical for condenser water pumps where cooling tower base is near mechanical room elevation.

Figure 7-8: Floor Saddle Support

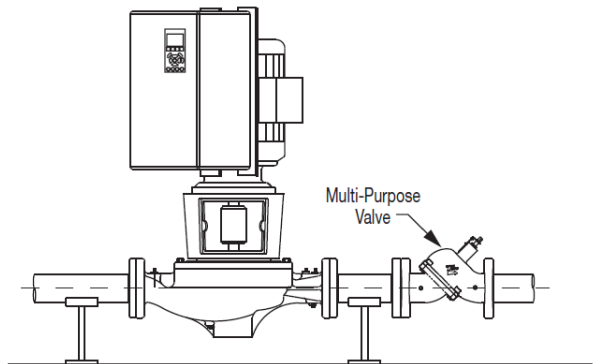

Where required, additional floor support may be used as shown in Figure 7-9. Install a "waffle" isolation pad under the pump. **NOTE:** The pump should not be rigidly attached to the base/pad structure.

Figure 7-9: Additional Floor Support

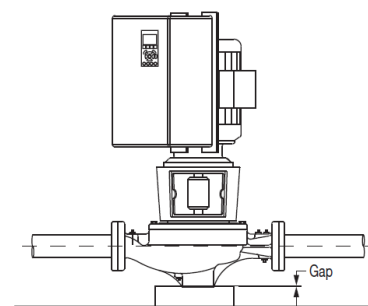

Stanchion plates at the pump suction and discharge ports may be supplied for installation convenience. Isolation pads must be used under the legs and monitored as pipe hangers are adjusted to ensure the pump flanges are not supporting the piping. Bolting to the floor or housekeeping pad is not recommended. If the stanchions are bolted down the bolts must be isolated from the stanchion or inertia base and flexible pipe connectors used (Figure 7-10).

Figure 7-10: With Stanchion Plates

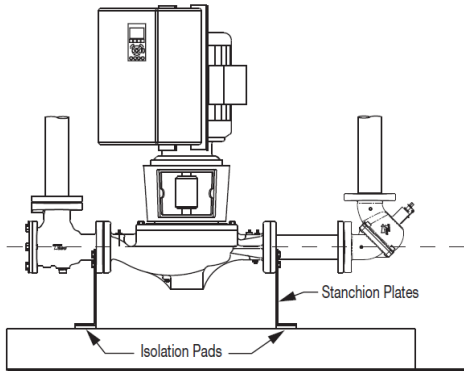

An installation with stanchion plates for seismically active regions is illustrated in Figure 7-11. Seismically rated isolation pads or snubbers with bolts isolated from the stanchion plates are installed to restrain the pump during a seismic event. Pipe hangers carry the weight of the equipment as seismic components are designed only to restrain the equipment during a seismic event.

Figure 7-11: Installation in Seismically Active Region

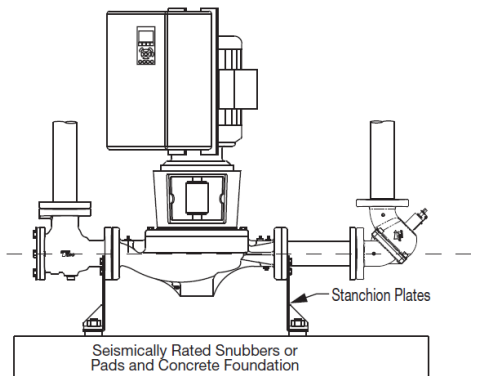

In systems utilizing grooved pipe, flange adapter locking devices or welded flanges at the pump should be used to prevent the possibility of pipe mounted pumps rotating in the piping (Figure 7-12).

Figure 7-12: Mounting in Grooved Pipe Systems

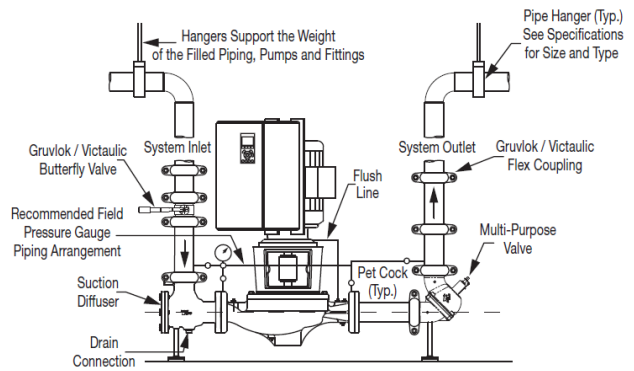

DO NOT support the unit by the motor eye bolts (Figure 7-13) or by any other part of the motor.

Figure 7-13: Motor Lifting Hook Supported

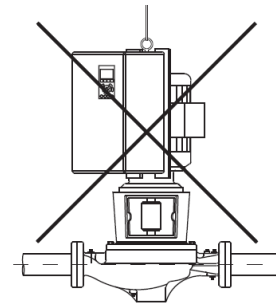

Connecting the pump to a permanent rigid base (Figure 7-14) is not recommended unless isolated from the piping by flexible connectors and the base isolated from the building structure on an inertia base. (Figure 7-14 is generally acceptable when using plastic piping.)

Figure 7-14: Mounted on Rigid Base without Flexible Connectors

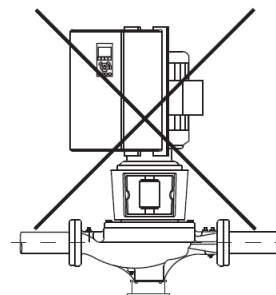

8 ELECTRICAL CONNECTIONS

8.1 Exploded Views

Figure 8-1: Exploded View A Size

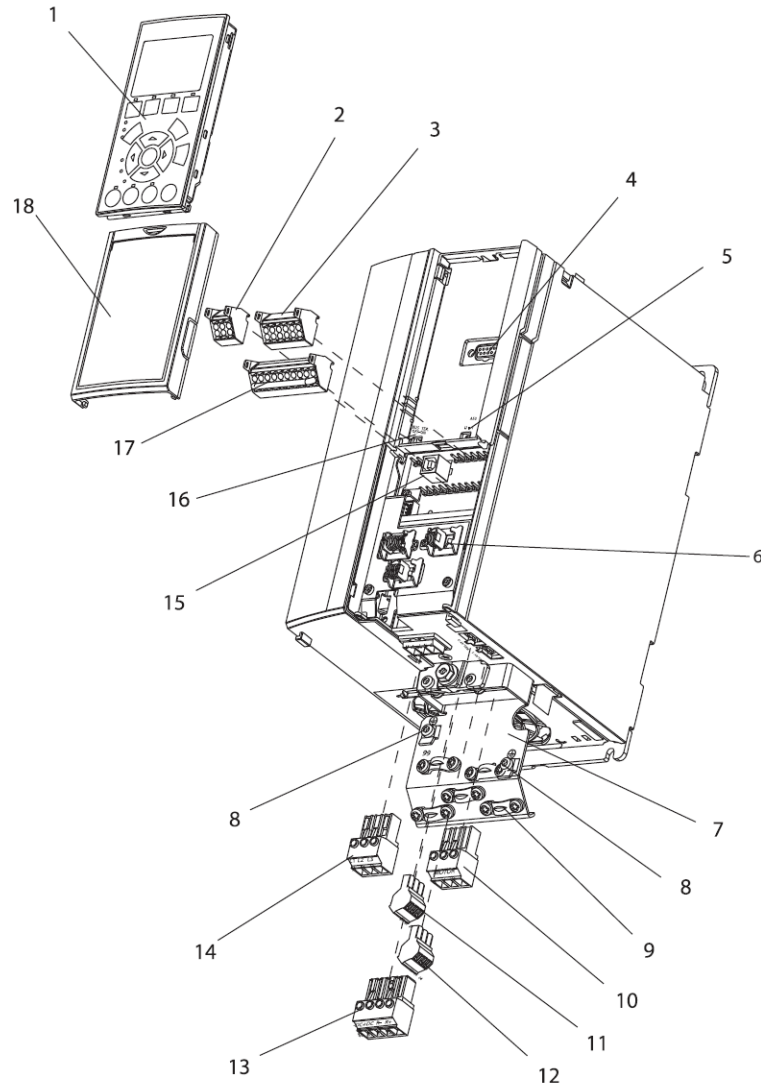

1	LCP	10	Motor output terminals 96 (U), 97 (V), 98 (W)
2	RS-485 serial bus connector (+68, -69)	11	Relay 1 (01, 02, 03)
3	Analog I/O connector	12	Relay 2 (04, 05, 06)
4	LCP input plug	13	Brake (-81, +82) and load sharing (-88, +89) terminals
5	Analog switches (A53), (A54)	14	Line power input terminals 91 (L1), 92 (L2), 93 (L3)
6	Cable strain relief / PE ground	15	USB connector
7	Decoupling plate	16	Serial bus terminal switch
8	Grounding clamp (PE)	17	Digital I/O and 24 V power supply
9	Shielded cable grounding clamp and strain relief	18	Control cable coverplate

Figure 8-2: Exploded View B and C Sizes

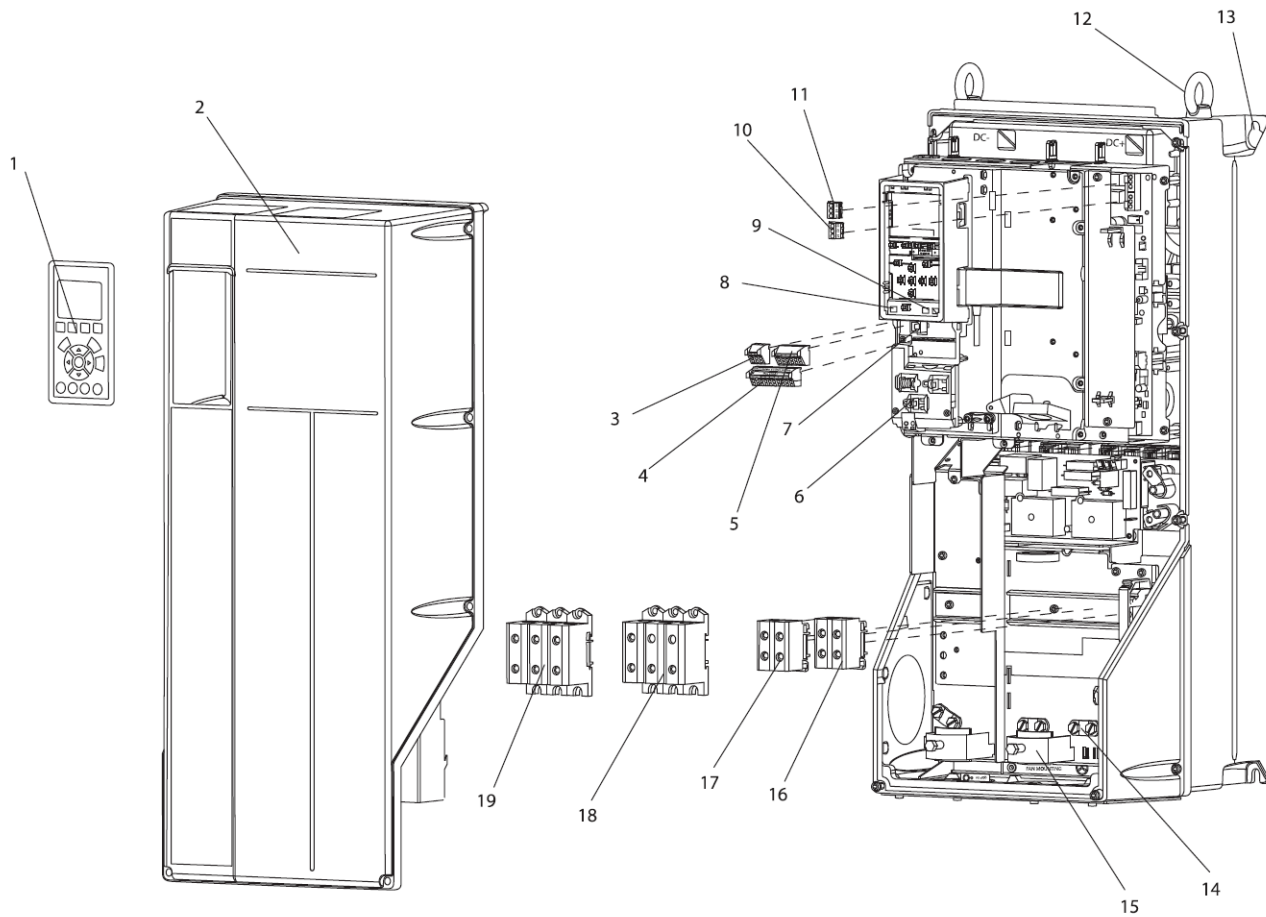

1	LCP	11	Relay 2 (04, 05, 06)
2	Cover	12	Lifting ring
3	RS-485 serial bus connector	13	Mounting slot
4	Digital I/O and 24 V power supply	14	Grounding clamp (PE)
5	Analog I/O connector	15	Cable strain relief / PE ground
6	Cable strain relief / PE ground	16	Brake terminal (-81, +82)
7	USB connector	17	Load sharing terminal (DC bus) (-88, +89)
8	Serial bus terminal switch	18	Motor output terminals 96 (U), 97 (V), 98 (W)
9	Analog switches (A53), (A54)	19	Line power input terminals 91 (L1), 92 (L2), 93 (L3)
10	Relay 1 (01, 02, 03)		

8.2 Electrical Installation

This section contains detailed instructions for wiring the adjustable frequency drive. The following tasks are described.

- Wiring the motor to the adjustable frequency drive output terminals
- Wiring the AC line power to the adjustable frequency drive input terminals
- Connecting control and serial communication wiring
- After power has been applied, checking input and motor power; programming control terminals for their intended functions

Figure 8-3 shows a basic electrical connection.

Figure 8-3: Basic Wiring Schematic Drawing

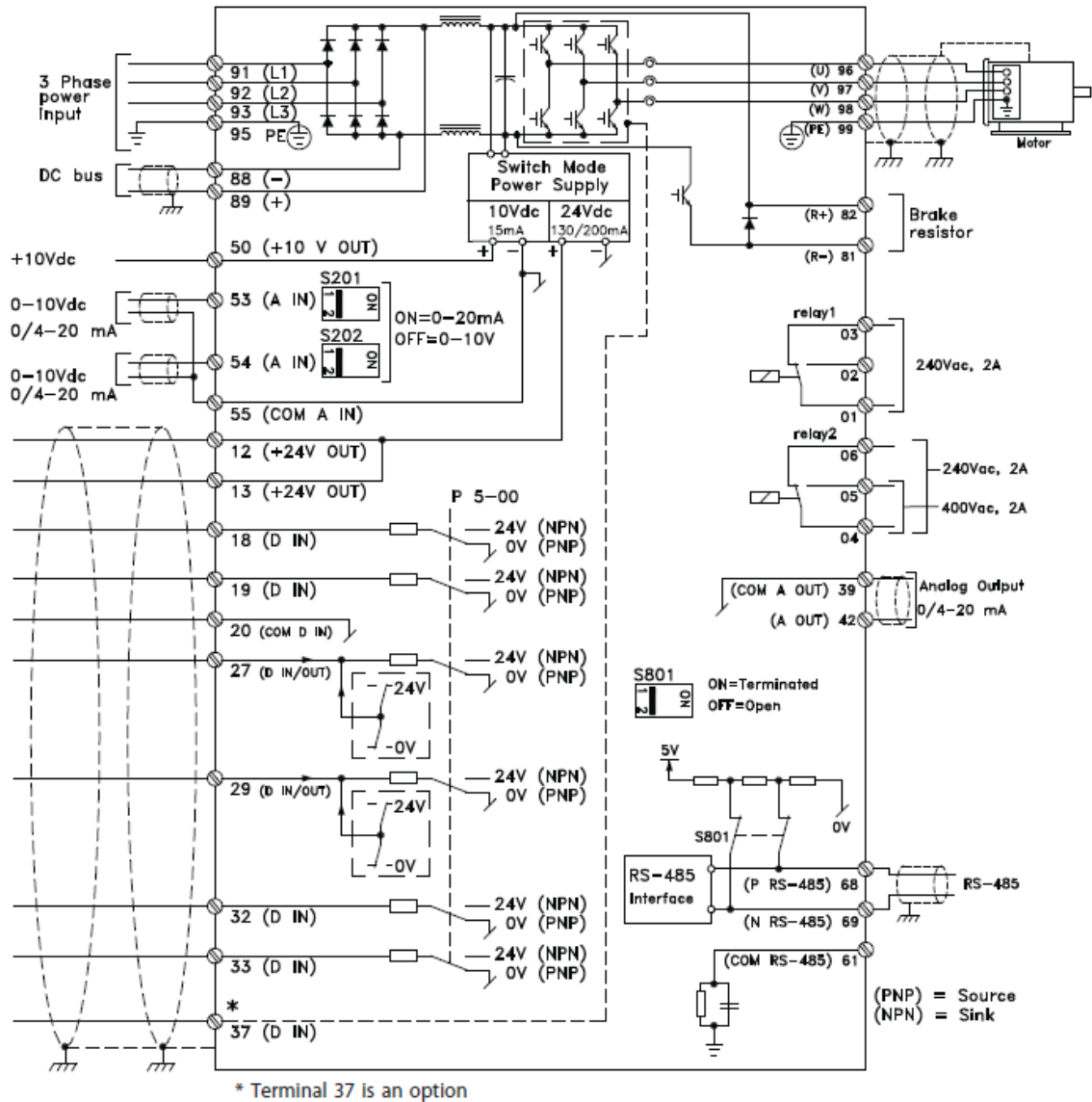

DANGER: EQUIPMENT HAZARD! Rotating shafts and electrical equipment can be hazardous. All electrical work must conform to national and local electrical codes. It is strongly recommended that installation, start-up, and maintenance be performed only by trained and qualified personnel. Failure to follow these guidelines could result in death or serious injury.



CAUTION: WIRING ISOLATION! Run input power, motor wiring and control wiring in three separate metallic conduits or use separated shielded cable for high frequency noise isolation. Failure to isolate power, motor and control wiring could result in less than optimum adjustable frequency drive and associated equipment performance.

For your safety, comply with the following requirements:

- Electronic controls equipment is connected to hazardous AC line voltage. Extreme care should be taken to protect against electrical hazards when applying power to the unit.
- Run motor cables from multiple adjustable frequency drives separately. Induced voltage from output motor cables run together can charge equipment capacitors even with the equipment turned off and locked out.

8.2.1 Overload and Equipment Protection

- An electronically activated function within the adjustable frequency drive provides overload protection for the motor. The overload calculates the level of increase to activate timing for the trip (controller output stop) function. The higher the current draw, the quicker the trip response. The overload provides Class 20 motor protection. See “14 Warnings and Alarms” on page 61 for details on the trip function.
- Because the motor wiring carries high frequency current, it is important that wiring for line power, motor power, and control is run separately. Use metallic conduit or separated shielded wire. Failure to isolate power, motor, and control wiring could result in less than optimum equipment performance. See Figure 8-4.

Figure 8-4: Proper Electrical Installation Using Flexible Conduit

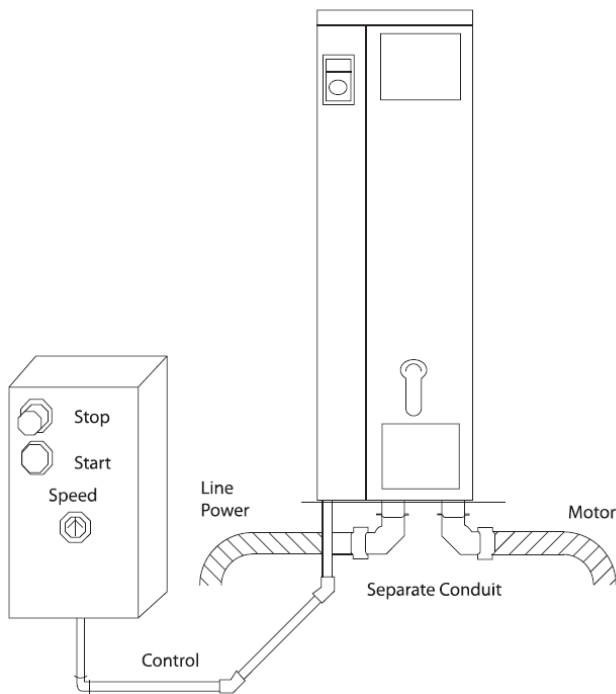

All adjustable frequency drives must be provided with short-circuit and overcurrent protection. Input fusing is required to provide this protection, see Figure 9.2.3. If not factory supplied, fuses must be provided by the installer as part of installation.

Figure 8-5: Adjustable Frequency Drive Fuses

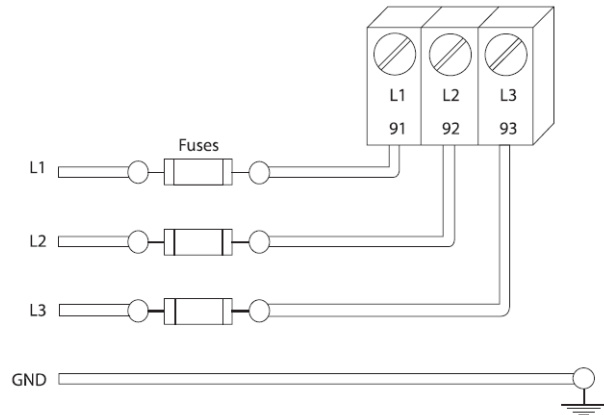

Wire Type and Ratings

- All wiring must comply with local and national regulations regarding cross-section and ambient temperature requirements.
- Danfoss recommends that all power connections be made with a minimum 167°F [75 °C] rated copper wire.

8.3 Grounding Requirements



DANGER: GROUNDING HAZARD! For operator safety, it is important to ground adjustable frequency drive properly in accordance with national and local electrical codes as well as instructions contained within these instructions. Ground currents are higher than 3.5 mA. Failure to ground the adjustable frequency drive properly could result in death or serious injury.

NOTE: It is the responsibility of the user or certified electrical installer to ensure correct grounding of the equipment in accordance with national and local electrical codes and standards.

- Follow all local and national electrical codes to ground electrical equipment properly.
- Proper protective grounding for equipment with ground currents higher than 3.5 mA must be established, see *Leakage Current (>3.5 mA)*.
- A dedicated ground wire is required for input power, motor power and control wiring.

- Use the clamps provided with on the equipment for proper ground connections.
- Do not ground one adjustable frequency drive to another in a “daisy chain” fashion.
- Keep the ground wire connections as short as possible.
- Use of high-strand wire to reduce electrical noise is recommended.
- Follow the motor manufacturer wiring requirements.

8.3.1 Leakage Current (>3.5 mA)

Follow national and local codes regarding protective grounding of equipment with a leakage current > 3.5 mA. Adjustable frequency drive technology implies high frequency switching at high power. This will generate a leakage current in the ground connection. A fault current in the adjustable frequency drive at the output power terminals might contain a DC component which can charge the filter capacitors and cause a transient ground current. The ground leakage current depends on various system configurations including RFI filtering, shielded motor cables, and adjustable frequency drive power EN/IEC61800-5-1 (Power Drive System Product Standard) requires special care if the leakage current exceeds 3.5mA.

Grounding must be reinforced in one of the following ways:

- Ground wire of at least 0.0155 in² [10mm²]
- Two separate ground wires both complying with the dimensioning rules

See EN/IEC61800-5-1 and EN50178 for further information.

8.3.2 Using RCDs

Where residual current devices (RCDs), also known as ground leakage circuit breakers (ELCBs), are used, comply with the following:

- Use RCDs of type B only which are capable of detecting AC and DC currents
- Use RCDs with an inrush delay to prevent faults due to transient ground currents
- Dimension RCDs according to the system configuration and environmental considerations

8.3.3 Grounding Using Shielded Cable

Grounding clamps are provided for motor wiring (see Figure 8-6).

Figure 8-6: Grounding with Shielded Cable

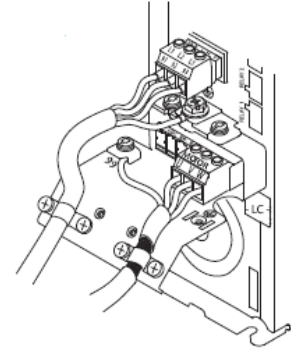

8.3.4 Grounding Using Conduit



DANGER: GROUNDING HAZARD! Do not use conduit connected to the adjustable frequency drive as a replacement for proper grounding. Ground currents are higher than 3.5 mA. Improper grounding can result in personal injury or electrical shorts.

Dedicated grounding clamps are provided (See Figure 8-7).

Figure 8-7: Grounding with Conduit

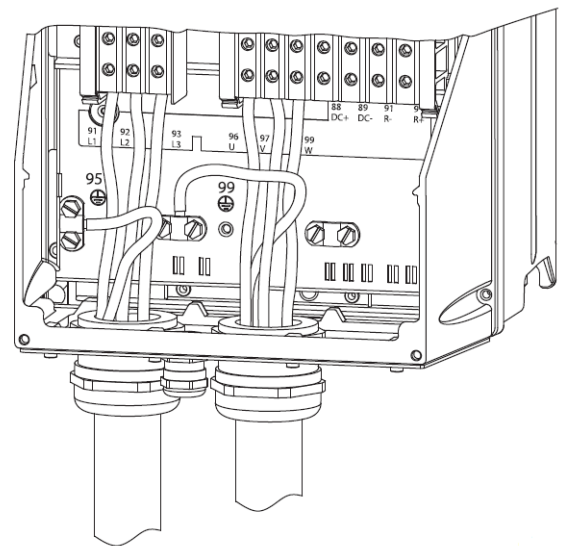

1. Use a wire stripper to remove the insulation for proper grounding.
2. Secure the grounding clamp to the stripped portion of the wire with the screws provided.
3. Secure the grounding wire to the grounding clamp provided.

8.3.5 Motor Connection



DANGER: INDUCED VOLTAGE! Run output motor cables from multiple adjustable frequency drives separately. Induced voltage from output motor cables run together can charge equipment capacitors even with the equipment turned off and locked out. Failure to run output motor cables separately could result in death or serious injury.

- For maximum wire sizes, see “17.1 Power-dependent Specifications” on page 75.
- Comply with local and national electrical codes for cable sizes.
- Motor wiring knockouts or access panels are provided at the base of IP21 and higher (NEMA1/12) units
- Do not install power factor correction capacitors between the adjustable frequency drive and the motor
- Do not wire a starting or pole-changing device between the adjustable frequency drive and the motor.
- Connect the 3-phase motor wiring to terminals 96 (U), 97 (V), and 98 (W).
- Ground the cable in accordance with grounding instructions provided.
- Follow the motor manufacturer wiring requirements

The three following figures represent line power input, motor, and grounding for basic adjustable frequency drives. Actual configurations vary with unit types and optional equipment.

Figure 8-8: Motor, Line Power and Ground Wiring for A-Frame Sizes

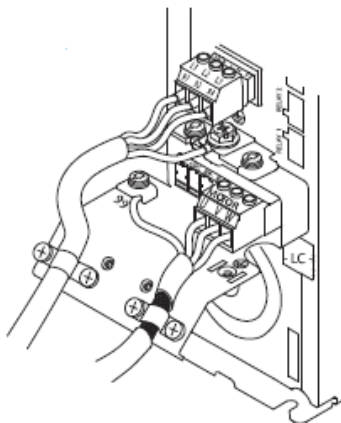

Figure 8-9: Motor, Line Power and Ground Wiring for B-Frame Sizes and Above Using Shielded Cable

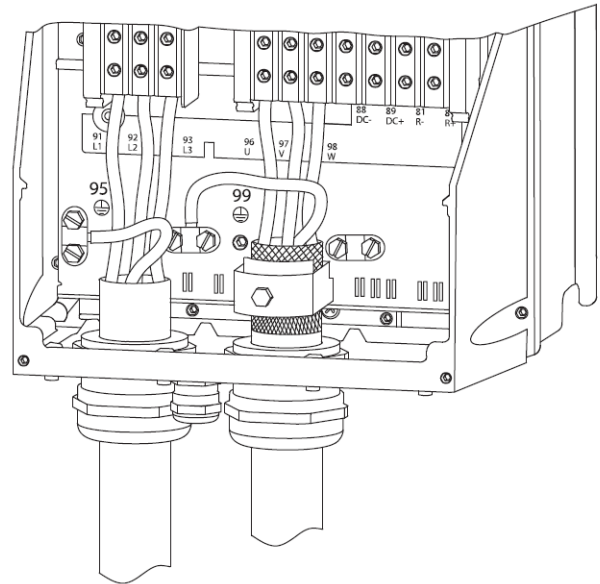
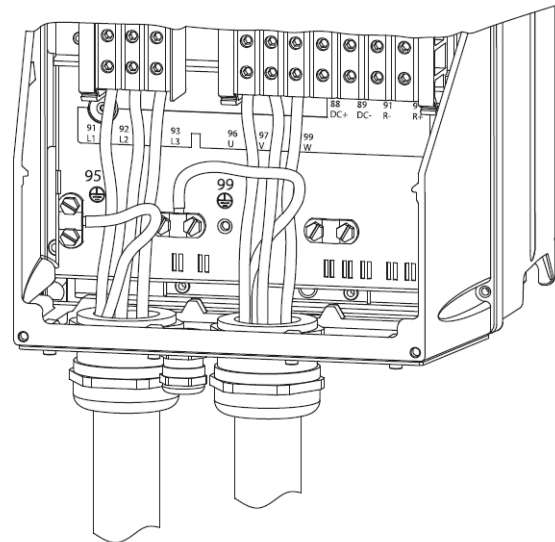

Figure 8-10: Motor, Line Power and Ground Wiring B-Frame Sizes and Above Using Shielded Cable or Conduit



8.3.6 AC Line Power Connection

Size wiring based upon the input current of the adjustable frequency drive.

- Comply with local and national electrical codes for cable sizes.
- Connect 3-phase AC input power wiring to terminals L1, L2, and L3 (see Figure 8-11).

- Depending on the configuration of the equipment, input power will be connected to the line power input terminals or the input disconnect.

Figure 8-11: Connecting to AC Line Power

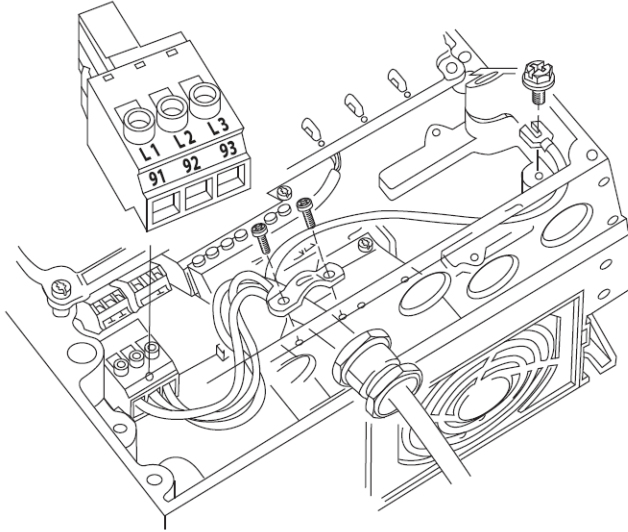

- Ground the cable in accordance with grounding instructions provided in “8.3 Grounding Requirements” on page 12.
- All adjustable frequency drives may be used with an isolated input source as well as with ground reference power lines. When supplied from an isolated line power source (IT line power or floating delta) or TT/TN-S line power with a grounded leg (grounded delta), set 14-50 RFI 1 to OFF. When off, the internal RFI filter capacitors between the chassis and the intermediate circuit are isolated to avoid damage to the intermediate circuit and to reduce ground capacity currents in accordance with IEC 61800-3.

8.3.7 Control Wiring

Isolate control wiring from high power components in the adjustable frequency drive.

If the adjustable frequency drive is connected to a thermistor, for PELV isolation, optional thermistor control wiring must be reinforced/ double insulated. A 24 VDC supply voltage is recommended.

Access

Remove access coverplate with a screwdriver. See “Figure 8-12: Control Wiring Access for A2, A3, B3, B4, C3 and C4 Enclosures” on page 15.

Or remove front cover by loosening attaching screws. See “Figure 8-13: Control Wiring Access for A4, A5, B1, B2, C1 and C2 Enclosures” on page 15.

Figure 8-12: Control Wiring Access for A2, A3, B3, B4, C3 and C4 Enclosures

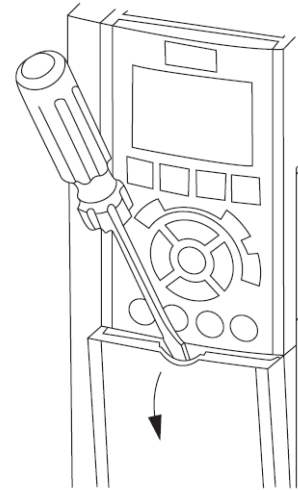
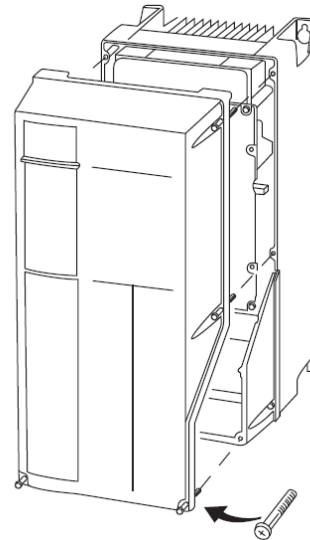

Figure 8-13: Control Wiring Access for A4, A5, B1, B2, C1 and C2 Enclosures



Please see the table below before tightening the covers.

Table 1: Tightening Torques for Covers (Nm)

Frame	IP20	IP21	IP55	IP66
A4/A5	-	-	2	2
B1	-	*	2.2	2.2
B2	-	*	2.2	2.2
C1	-	*	2.2	2.2
C2	-	*	2.2	2.2
* No screws to tighten - Does not exist				

Control Terminal Types

Figure 8-14 shows the removable adjustable frequency drive connectors.

Figure 8-14: Control Terminal Locations

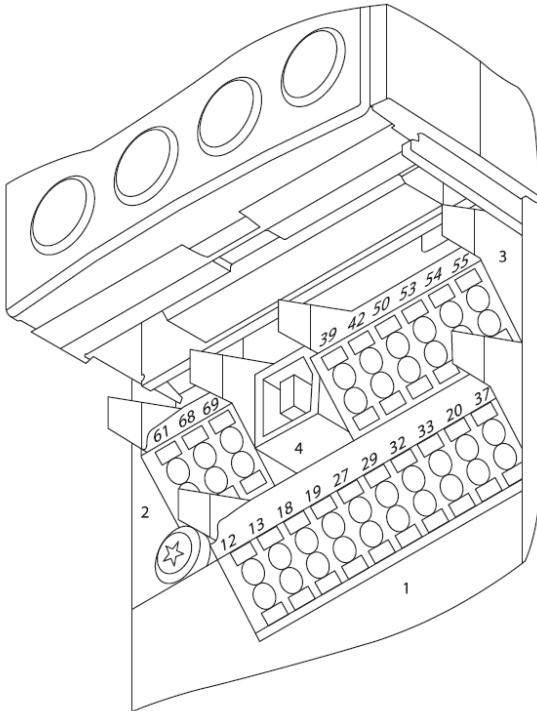

- Connector 1 provides four programmable digital inputs terminals, two additional digital terminals programmable as either input or output, a 24V DC terminal supply voltage, and a common for optional customer supplied 24V DC voltage.
- Connector 2 terminals (+)68 and (-)69 are for an RS-485 serial communications connection.
- Connector 3 provides two analog inputs, one analog output, 10V DC supply voltage, and commons for the inputs and output.
- Connector 4 is a USB port available for use with the MCT-10 Set-up Software.
- Also provided are two Form C relay outputs that are in various locations depending upon the adjustable frequency drive configuration and size.

Wiring to Control Terminals

Control terminal connectors can be unplugged from the adjustable frequency drive for ease of installation, as shown in Figure 8-15.

Figure 8-15: Unplugging Control Terminals

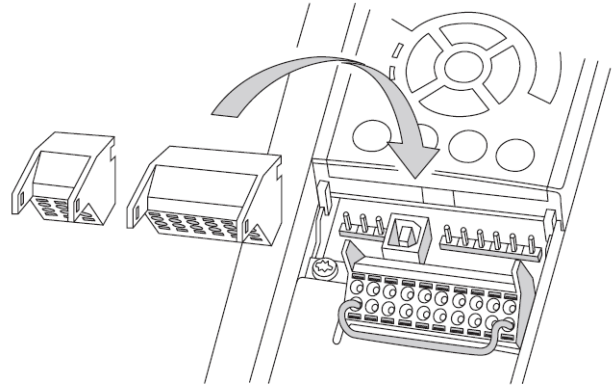

1. Open the contact by inserting a small screwdriver into the slot above or below the contact, as shown in Figure 8-16.
2. Insert the bared control wire into the contact.
3. Remove the screwdriver to fasten the control wire into the contact.
4. Ensure the contact is firmly established and not loose. Loose control wiring can be the source of equipment faults or less than optimal operation.

Figure 8-16: Connecting Control Wiring

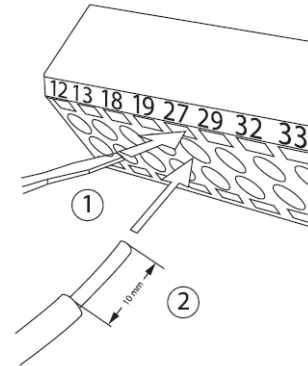

Using Shielded Control Cables

Correct Shielding

The preferred method in most cases is to secure control and serial communication cables with shielding clamps provided at both ends to ensure best possible high frequency cable contact.

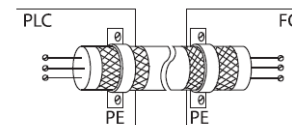

50/60 Hz ground loops

With very long control cables, ground loops may occur. To eliminate ground loops, connect one end of the shield-to-ground with a 100 nF capacitor (keeping leads short).

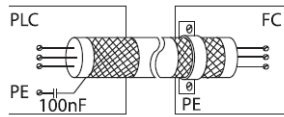

Avoid EMC noise on serial communication

To eliminate low-frequency noise between adjustable frequency drives, connect one end of the shield to terminal 61. This terminal is connected to ground via an internal RC link. Use twisted-pair cables to reduce interference between conductors.

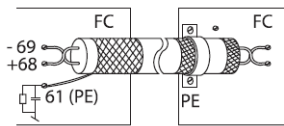

Control Terminal Functions

Adjustable frequency drive functions are commanded by receiving control input signals.

- Each terminal must be programmed for the function it will be supporting in the parameters associated with that terminal.
- It is important to confirm that the control terminal is programmed for the correct function. See “9 User Interface” on page 28 for details on accessing parameters..
- The default terminal programming is intended to initiate adjustable frequency drive functioning in a typical operational mode.

Jumper Terminals 12 and 27

A jumper wire may be required between terminal 12 (or 13) and terminal 27 for the adjustable frequency drive to operate when using factory default programming values.

- Digital input terminal 27 is designed to receive an 24VDC external interlock command. In many applications, the user wires an external interlock device to terminal 27.
- When no interlock device is used, wire a jumper between control terminal 12 (recommended) or 13 to terminal 27. This provides an internal 24 V signal on terminal 27.
- No signal present prevents the unit from operating.
- When the status line at the bottom of the LCP reads “AUTO REMOTE COASTING” or “Alarm 60 External Interlock” is displayed, this indicates that the unit is ready to operate but is missing an input signal on terminal 27.

- When factory installed optional equipment is wired to terminal 27, do not remove that wiring.

Terminal 53 and 54 Switches

- Analog input terminals 53 and 54 can select either voltage (0 to 10V) or current (0/4–20mA) input signals
- Remove power to the adjustable frequency drive before changing switch positions.
- Set switches A53 and A54 to select the signal type. U selects voltage, I selects current.
- The switches are accessible when the LCP has been removed (see Figure 8-17). Note that some option cards available for the unit may cover these switches and must be removed to change switch settings. Always remove power to the unit before removing option cards.
- Terminal 53 default is for a speed reference signal in open-loop set in 16-61 Terminal 53 Switch Setting
- Terminal 54 default is for a feedback signal in closed-loop set in 16-63 Terminal 54 Switch Setting

Figure 8-17: Location of Terminals 53 and 54 Switches

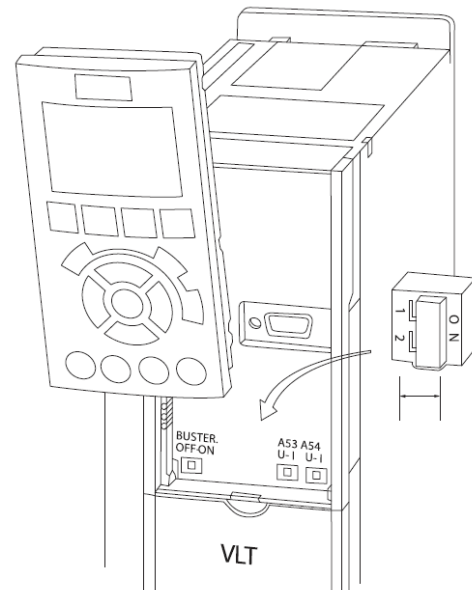

8.4 Typical Terminal Wiring Configurations

The unit connection blocks are shown in “Figure 8-14: Control Terminal Locations” on page 16.

Table 2: Control Terminal Information

	Terminal number	Parameter	Default setting	Description
Relay Outputs	01, 02, 03	5-40 Relay 1	[160] No Alarm	Form C Relay Output. Used for AC or DC voltages and either resistive or inductive loads. see the following section on relay wiring for contact current and voltage ratings.
	04, 05, 06	5-40 Relay 2	[5] Running	
Connector 1	12, 13	-	+24 V DC	24 V DC supply voltage. Maximum output current is 200 mA total for all 24 V loads. Intended for digital inputs, external transducers.
	18	5-10	[8] Start	Start/Stop digital input signal for the drive. Connect input to 24 V to start. Open the input to stop the drive.
	19	5-11	[0] No Operation	Digital input (not used)
	27	5-12	[0] No Operation	Digital input (not used)
	29	5-13	[0] No Operation	Digital input (not used)
	32	5-14	[0] No Operation	Digital input (not used)
	33	5-15	[0] No Operation	Digital input (not used)
	20	-	Common	Common for digital inputs and reference for 24 V supply
Connector 2	61	-	Shield Connection	Integrated RC filter for cable shield. ONLY for connecting the shield when experiencing EMC problems.
	68	8-3	+	RS485 Interface (+)
	69	8-3	-	RS485 Interface (-)
Connector 3	39	-	AO Common	Common for analog output
	42	6-50	4-20mA Motor Freq	Analog output. Default setting is 4-20mA signal (500 ohms maximum) based on motor speed.
	50	-	+10 V DC	10 V DC analog supply voltage. 15mA max.
	53	6-1	[0] No Operation	Analog input 53.
	54	6-2	[0] No Operation	Analog input 54.
	55	-	AI Common	Common for analog input.

Figure 8-18: Control Terminal Connectors 1-4 and Relay Output Locations

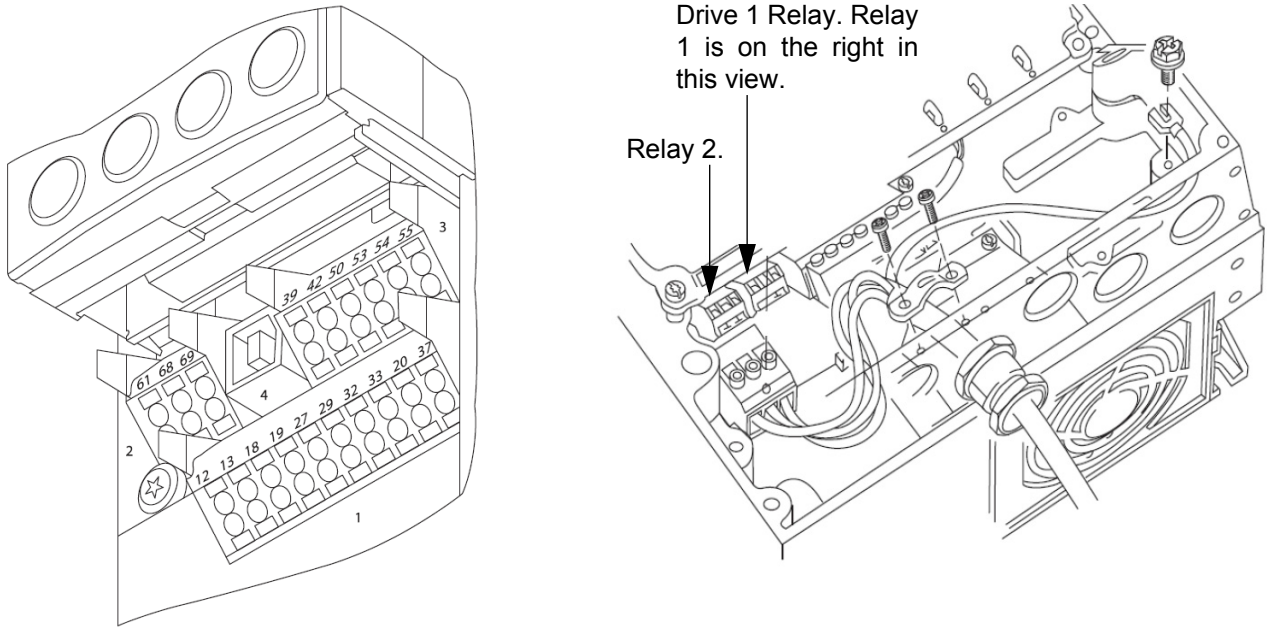

8.4.1 Factory default set-up

This configuration makes use of the controller factory default settings for input/output. The factory default settings are configured for Set-up 1, SelfSensing system curve control without an external transducer. No parameters need to be changed to use this configuration. Set-up 3, SelfSensing constant flow control, uses the same default settings.

Set-ups can be changed by modifying the parameter 0-10 Active Set-up.

NOTE: The factory default settings require a start signal wired to DI18 (see below).

Comm Port			I/O Analog						I/O Digital								
61	68	69	39	42	50	53	54	55	12	13	18	19	27	29	32	33	20
SHLD	+	-	COM	AOUT	+10V	A IN	A IN	COM	+24V	+24V	D IN	D IN	D IN	D IN	D IN	D IN	COM
<input type="checkbox"/>	<input type="checkbox"/>	<input type="checkbox"/>	<input type="checkbox"/>	<input type="checkbox"/>	<input type="checkbox"/>	<input type="checkbox"/>	<input type="checkbox"/>	<input type="checkbox"/>	<input type="checkbox"/>	<input type="checkbox"/>	<input type="checkbox"/>	<input type="checkbox"/>	<input type="checkbox"/>	<input type="checkbox"/>	<input type="checkbox"/>	<input type="checkbox"/>	<input type="checkbox"/>
<input type="radio"/>	<input type="radio"/>	<input type="radio"/>	<input type="radio"/>	<input type="radio"/>	<input type="radio"/>	<input type="radio"/>	<input type="radio"/>	<input type="radio"/>	<input type="radio"/>	<input type="radio"/>	<input type="radio"/>	<input type="radio"/>	<input type="radio"/>	<input type="radio"/>	<input type="radio"/>	<input type="radio"/>	<input type="radio"/>
<input type="radio"/>	<input type="radio"/>	<input type="radio"/>	<input type="radio"/>	<input type="radio"/>	<input type="radio"/>	<input type="radio"/>	<input type="radio"/>	<input type="radio"/>	<input type="radio"/>	<input type="radio"/>	<input type="radio"/>	<input type="radio"/>	<input type="radio"/>	<input type="radio"/>	<input type="radio"/>	<input type="radio"/>	<input type="radio"/>
<input type="checkbox"/>	<input type="checkbox"/>	<input type="checkbox"/>	<input type="checkbox"/>	<input type="checkbox"/>	<input type="checkbox"/>	<input type="checkbox"/>	<input type="checkbox"/>	<input type="checkbox"/>	<input type="checkbox"/>	<input type="checkbox"/>	<input type="checkbox"/>	<input type="checkbox"/>	<input type="checkbox"/>	<input type="checkbox"/>	<input type="checkbox"/>	<input type="checkbox"/>	<input type="checkbox"/>

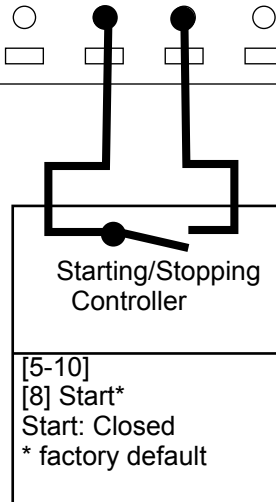

8.4.2 Relay Outputs

As shown above, each unit has two form C programmable relay outputs. The relay terminals can be found on the controller in various locations according to the frame size.

Figure 8-19: Wiring the Relay Terminals

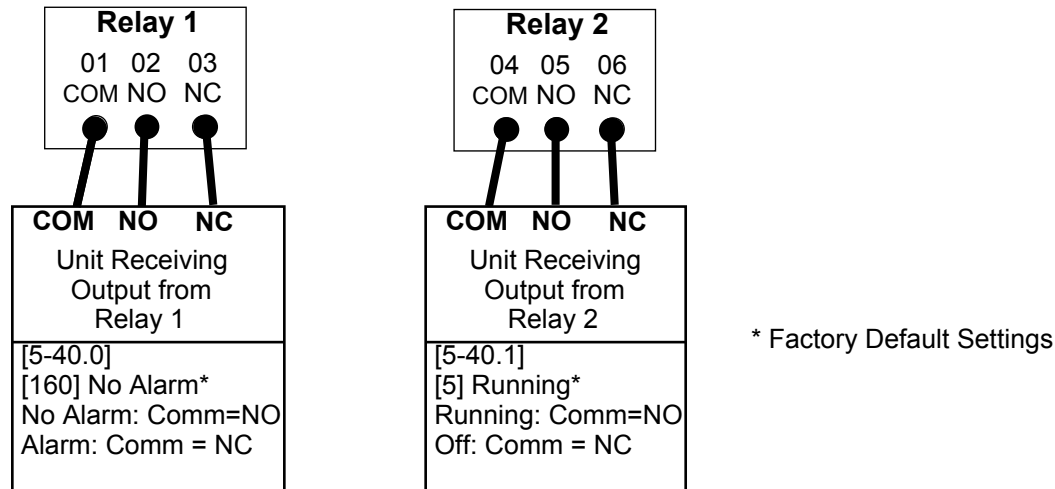

Table 3: Relay Terminal Specifications

Programmable relay outputs	2
Relay 01 Terminal number	1–3 (break), 1–2 (make)
Maximum terminal load (AC-1) on 1–3 (NC), 1–2 (NO) (Resistive load)	240 V AC, 2A
Maximum terminal load (AC-15) (Inductive load @ $\cos\phi$ 0.4)	240 V AC, 0.2A
Maximum terminal load (DC-1) on 1–2 (NO), 1–3 (NC) (Resistive load)	60 V DC, 1A
Maximum terminal load (DC-13) (Inductive load)	24 V DC, 0.1A
Relay 02 Terminal number	4–6 (break), 4–5 (make)
Maximum terminal load (AC-2) on 4–5 (NO) (resistive load)	400 V AC, 2A
Maximum terminal load (AC-15) (Inductive load @ $\cos\phi$ 0.4)	240 V AC, 0.2A
Maximum terminal load (DC-1) on 4–5 (NO) (Resistive load)	80 V DC, 2A
Maximum terminal load (DC-13) on 4–5 (NO) (Inductive load)	24 V DC, 0.1A
Maximum terminal load (AC-1) on 4–6 (NC) (Resistive load)	240 V AC, 2A
Maximum terminal load (AC-15) on 4–6 (NC) (Inductive load @ $\cos\phi$ 0.4)	240 V AC, 0.2A
Maximum terminal load (DC-1) on 4–6 (NC) (Resistive load)	50 V DC, 2A
Maximum terminal load (DC-13) on 4–6 (NC) (Inductive load)	24 V DC, 0.1A
Minimum terminal load on 1–3 (NC), 1–2 (NO), 4–6 (NC), 4–5 (NO)	24 V DC 10mA, 24 V AC 20mA
Environment according to EN 60664–1	overvoltage category III/pollution degree 2

8.4.3 Adding Transducer Input

This configuration adds a transducer for closed loop control or external monitoring. Use Set-up 4 for pressure control (Delta P) using a wired pressure transducer.

NOTE: Analog input configuration switches must be set before using the analog input, as shown in Figure 8-21.

Figure 8-20: Terminal Wiring for 4–20mA Sensor

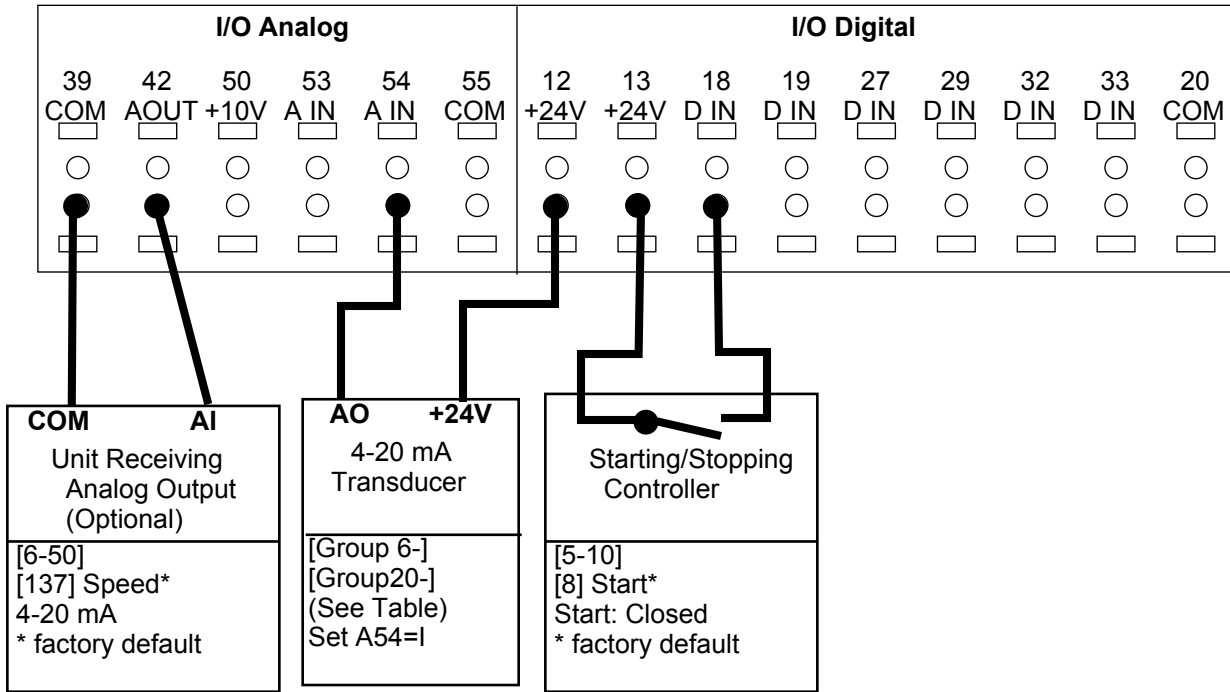
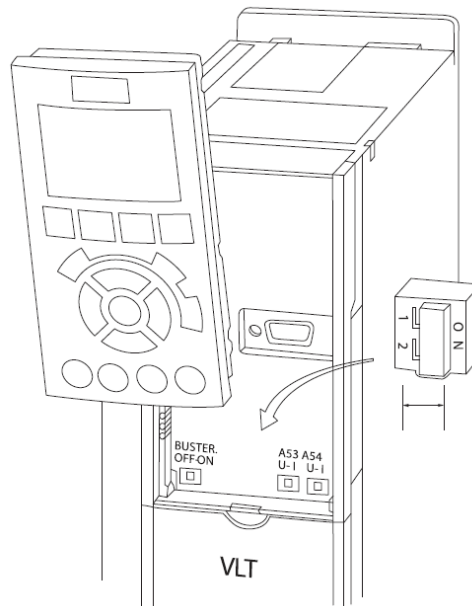
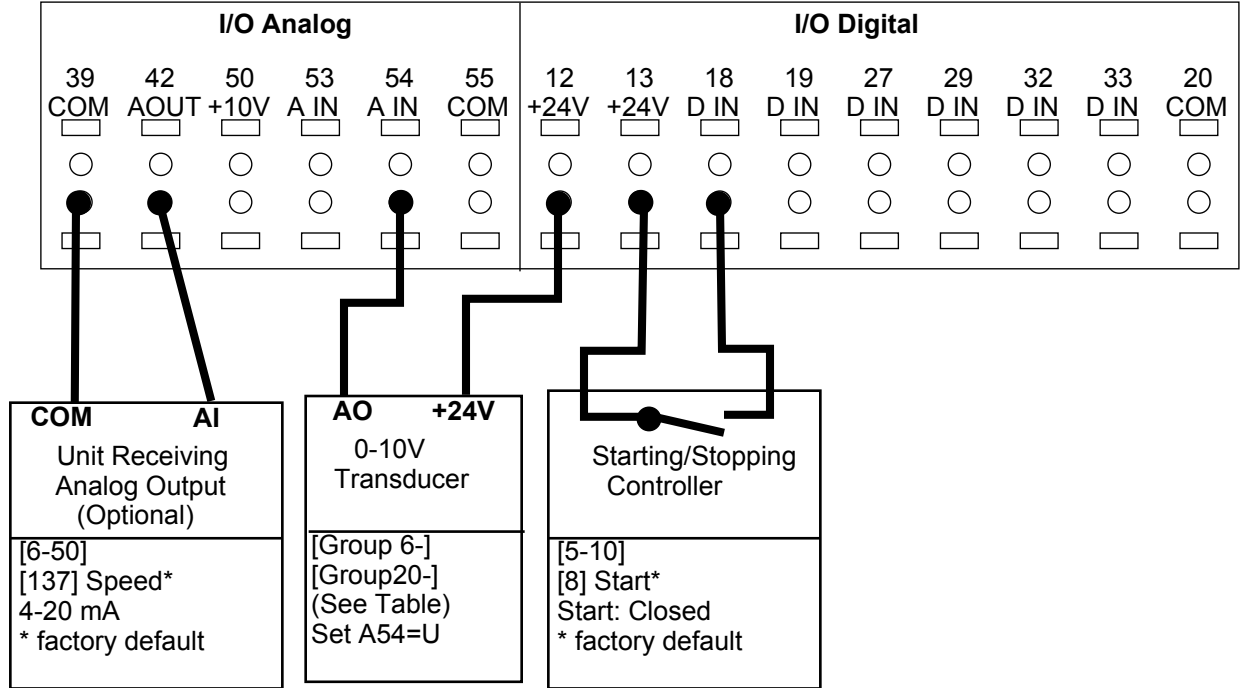

Figure 8-21: Location of Terminals 53 and 54 Switches



The following wiring scheme is used with Set-up 4 as shown in “10.1 SelfSensing Description” on page 34.

Figure 8-22: Terminal Wiring for 0–10V Sensor



To configure the controller for closed loop control based on the input from an external transducer, use the following parameters:

Table 4: Settings for a Wired Sensor for Input

Parameter number	Description	Set to
0–10	Active Set-up	For wired pressure transducer, choose Set-up 4.
6-24*	Terminal 54 Low Ref./Feedb. Value	Minimum transducer input value. For example, for a 0–100 PSI transducer, set to 0. For live 0 function set feedback to 1V or 10 PSI. Note: Live 0 does not work if minimum is set to 0.
6-25*	Terminal 54 High Ref./Feedb. Value	Maximum transducer input value. For example, for a 0–100 PSI transducer, set to 100.
6-27*	Terminal 54 Live Zero	Enabled
20-00	Feedback 1 Source	Analog Input 54*
20-12	Reference/Feedback	Set as appropriate for application. For example, set to PSI when using a pressure transducer. The default value for this setting is PSI.
20-13	Minimum Reference/Feed-back	Minimum transducer input value. For example, for a 0–100 PSI transducer, set to 0 PSI.
20-14	Maximum Reference/Feed-back	Maximum transducer input value. For example, for a 100 PSI transducer, set to 100 PSI.

* To use AI 53, set parameters 6–14, 6–15, 6–17 and set 20–00 to “Analog Input 53.”

To set up the controller with a transducer that is intended for external monitoring, as opposed to feedback to the controller, set the following parameters:

Table 5: Settings for a Wired Sensor for External Monitoring

Parameter number	Description	Set to
0-24	Display Line 3 Large	Ext. 1 Feedback [Unit]
21-14	Ext. 1 Feedback Source	Analog Input 54*
21-10	Ext. 1 Ref./Feedback Unit	Select as appropriate for application. For example, set to PSI when using a pressure transducer.
21-11	Ext. 1 Minimum Reference	Minimum transducer input value. For example, for a 0–60 PSI transducer, set to 0 PSI.
21-12	Ext. 1 Maximum Reference	Maximum transducer input value. For example, for a 60 PSI transducer, set to 60 PSI.
6-24*	Terminal 54 Low Ref./Feedb. Value	Minimum transducer input value. For example, for a 0–60 PSI transducer, set to 0 PSI.
6-25*	Terminal 54 High Ref./Feedb. Value	Maximum transducer input value. For example, for a 60 PSI transducer, set to 60 PSI.
6-27*	Terminal 54 Live Zero	Disabled

* To use AI 53, set parameters 6-14, 6-15, 6-17 and set 20-00 to “Analog Input 53.”

8.4.4 Speed control with external potentiometer

This configuration allows an external potentiometer to control the speed of the motor. To use this set-up, the analog input must be configured as a voltage input.

The following wiring scheme is used with Set-up 2 as shown in “10.1 SelfSensing Description” on page 34.

Figure 8-23: Terminal Wiring for Potentiometer used as External Speed Reference

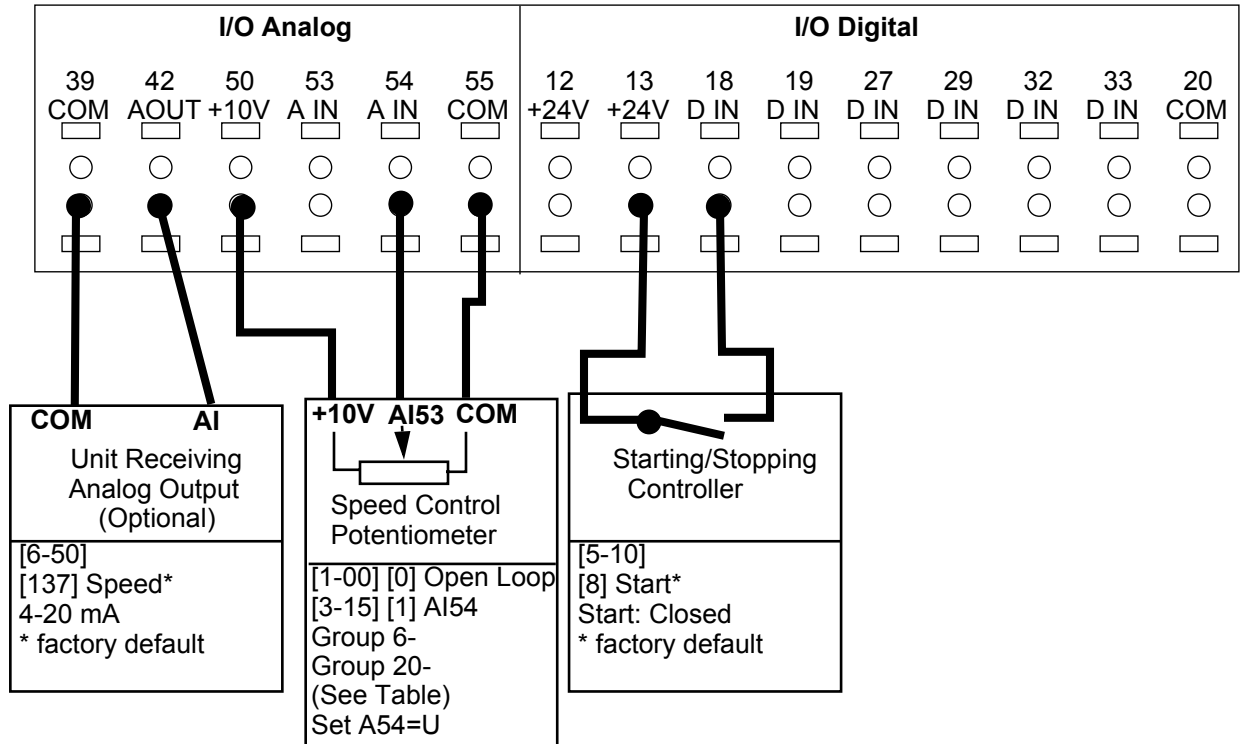

To set up the controller for speed control with an external potentiometer, set the following parameters:

Parameter number	Description	Set to
1-00	Configuration Mode	Open Loop
3-15	Reference 1 Source	Analog Input 54
6-20	Terminal 54 Low Voltage*	0 V
6-21	Terminal 54 High Voltage*	10 V
6-24	Terminal 54 Low Ref./Feedb. Value	0
6-25	Terminal 54 High Ref./Feedb. Value	Maximum motor speed. For example, 2950 Hz.
6-27	Terminal 54 Live Zero	Disabled.
20-00	Feedback 1 Source	No Function

* Set switch A54 = U

8.4.5 Control from external PLC/BMS through Analog Input

This set-up allows an external control source such as a PLC or BMS controller to provide: a) the process variable, b) the setpoint or c) a speed reference. The output from the external control device can be either a voltage or current signal. The analog input configuration switches must be set to the correct type of output signal. The drawing below shows the connections for this configuration.

This wiring scheme is used with Set-up 2, as shown in “10.1 SelfSensing Description” on page 34.

Figure 8-24: Terminal Wiring for External Control Source

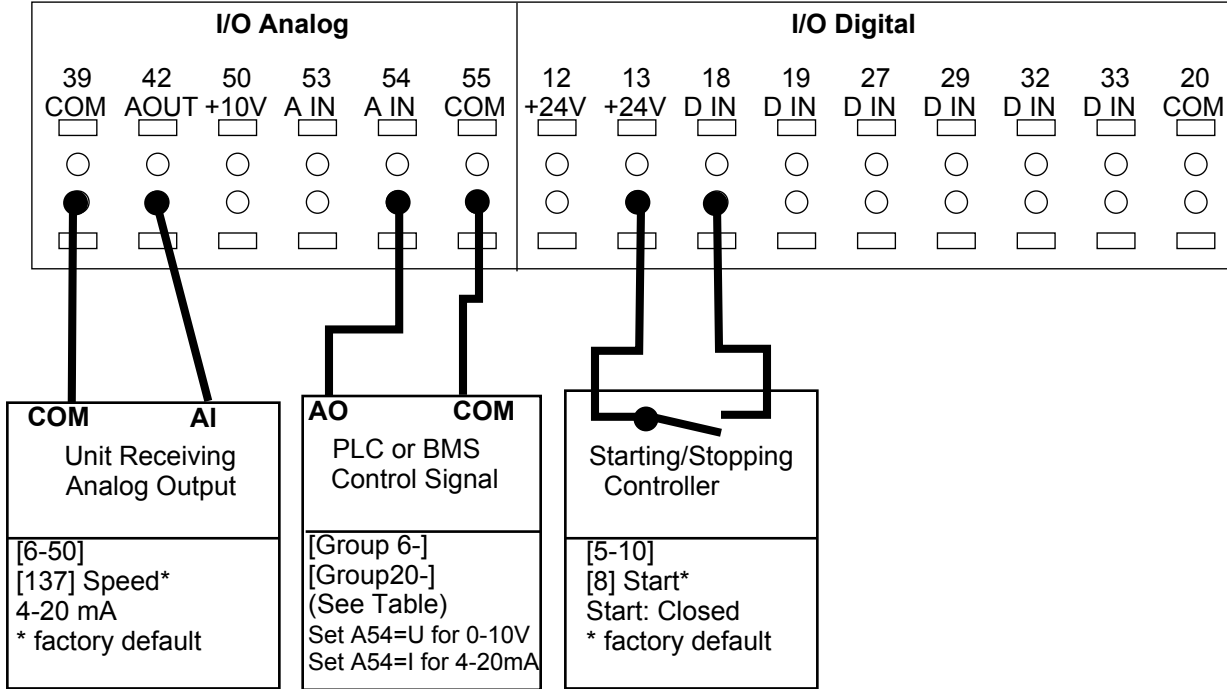

Table 6: Parameter Configuration for Use of an External Control Signal

Parameter Number	Parameter Description	For process variable from BMS/PLC*	For setpoint from BMS/ PLC**	For speed reference from BMS/PLC***
1-00	Configuration Mode	Closed Loop	Closed Loop	Open Loop
3-15	Reference 1 Source	No Function	Analog Input 54*	Analog Input 54*
6-24	Terminal 54 Low Ref./Feedb. Value	Minimum value of process variable. For example, for a 0-60PSI transducer, set to 0.	Minimum reference/setpoint value. For example, for a 0-60PSI DP transducer, set to 0.	Minimum motor speed. For example, 0 RPM.
6-25	Terminal 54 High Ref./Feedb. Value	Maximum value of process variable. For example, for a 60PSI transducer, set to 60.	Maximum reference/setpoint value. For example, for a 60PSI DP transducer, set to 60.	Maximum motor speed. For example, 2950 RPM.
6-27	Terminal 54 Live Zero	Enabled	Enabled	Disabled
20-00	Feedback 1 Source	Analog Input 54	Select as appropriate for application. This can be any selection except the setting of parameter 3-15.	No Function
20-12	Reference/Feedback Unit	Select as appropriate for application. For example, set to PSI when using pressure feedback.	Select as appropriate for application. For example, set to PSI when using pressure reference.	NA
20-14	Maximum Reference/Feedback	Maximum transducer feedback value. For example, for a 60PSI transducer, set to 60 PSI.	Maximum reference/setpoint value. For example, for a 60PSI transducer, set to 60 PSI.	NA

* To use AI 53, configure parameters 6-14, 6-15, 6-17 and set 20-00 to Analog Input 53

8.4.6 Control From External PLC/BMS Using Communications Port

The controller can be controlled from a BMS or PLC through the communications port. In this configuration, the BMS or PLC overrides the setpoint to control the drive. Control cables must be braided screened/shielded and the screen must be connected to the metal cabinet of the controller using two cable clamps (one at each end). The bus connections must be terminated by turning the BUS TER switch to the on position. This switch can be found under the LCP, when the LCP is detached.

This wiring scheme is used with Set-up 2, as shown in “10.1 SelfSensing Description” on page 34.

Figure 8-25: Terminal Connections for External Control via Communications Port

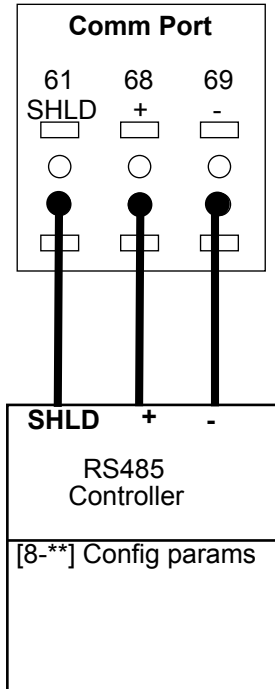

Table 7: Parameter settings for Modbus RTU and BACnet protocols

Parameter Number	Parameter Description	Protocol	
		Modbus RTU	BACnet
8-02	Control Source	FC Port	FC Port
8-30	Protocol	Modbus RTU	BACnet
8-31	Address	1	1
8-32	Baud Rate	19200	9600
8-33	Parity/Stop bit	Even Parity, 1 Stop bit	No Parity, 1 Stop bit
8-34	Estimated cycle time	0 ms	0 ms
8-35	Minimum Response Delay	10 ms	10 ms
8-36	Maximum Response Delay	5000 ms	5000 ms
8-37	Maximum Inter-Char Delay	0.86 ms	25 ms

The parameters above show a typical scenario used for Modbus RTU or BACnet protocols. The parameters must be set as appropriate for the devices on the network. 8-32 *Baud Rate* and 8-33 *Parity/Stop Bit* should be set to match the other devices on the network. For specific communication set-up information for Modbus RTU, refer to the document number MG92B102. For specific communication set-up information for BACnet, see documents MG14C102 and MG11D202. These documents can be downloaded from www.danfoss.com.

9 USER INTERFACE

9.1 Local Control Panel

The local control panel (LCP) is the combined display and keypad on the front of the unit. The LCP is the user interface to the adjustable frequency drive.

The LCP has several user functions.

- Start, stop, and control speed when in local control
- Display operational data, status, warnings and cautions
- Programming adjustable frequency drive functions
- Manually reset the adjustable frequency drive after a fault when auto-reset is inactive

LCP Layout

The LCP is divided into four functional groups (see Figure 9-1).

Figure 9-1: LCP

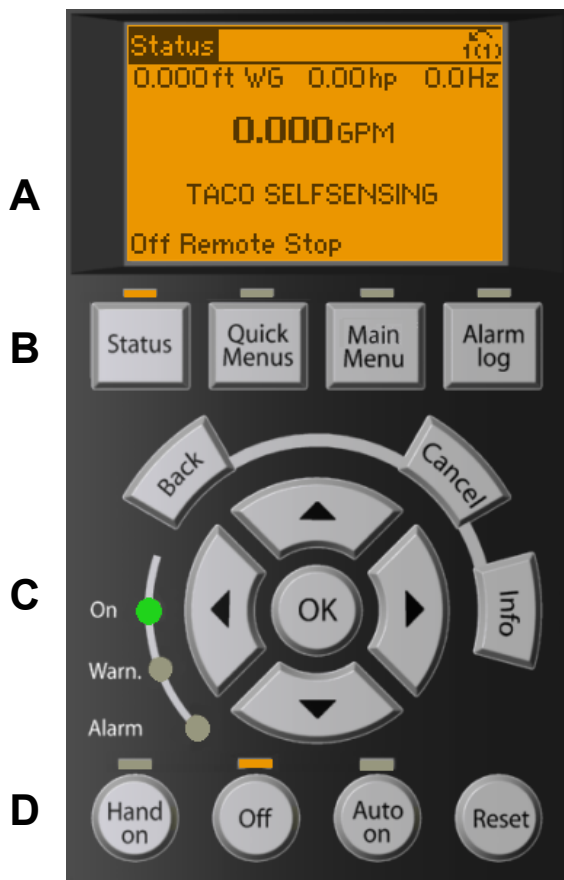

a. Display area

- Display menu keys for changing the display to show status options, programming, or error message history.
- Navigation keys for programming functions, moving the display cursor, and speed control in local operation. Also included are the status indicators.
- Operational mode keys and reset.

Setting LCP Display Values

The display area is activated when the adjustable frequency drive receives power from AC line voltage, a DC bus terminal, or an external 24V supply.

The information displayed on the LCP can be customized for user application.

- Each display readout has a parameter associated with it.
- Options are selected in the quick menu Q3-13 Display Settings.
- Display 2 has an alternate larger display option.
- The adjustable frequency drive status at the bottom line of the display is generated automatically and is not selectable.

Display	Parameter number	Default setting
1.1	0-20	Head
1.2	0-21	Motor Horsepower
1.3	0-22	Motor Hz
2	0-23	GPM

Figure 9-2: Status Display

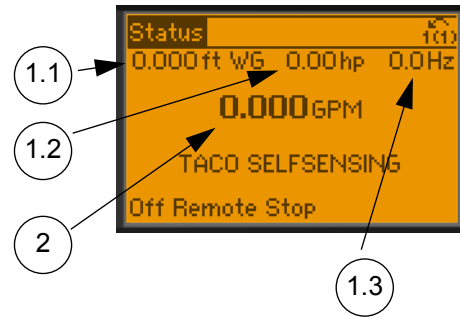

Display Menu Keys

Menu keys are used for menu access for parameter set-up, toggling through status display modes during normal operation, and viewing fault log data.



Key	Function
Status	Press to show operational information. <ul style="list-style-type: none"> • In Auto mode, press and hold to toggle between status readout displays. • Press repeatedly to scroll through each status display. • Press and hold [Status] plus [▲] or [▼] to adjust the display brightness. • The symbol in the upper right corner of the display shows the direction of motor rotation and which set-up is active. This is not programmable.
Quick Menu	Allows access to programming parameters for initial set-up instructions and many detailed application instructions. <ul style="list-style-type: none"> • Press to access <i>Q2 Quick Set-up</i> for sequenced instructions to program the basic adjustable frequency drive set-up. • Press to access <i>Q3 Function Set-ups</i> for sequenced instructions to program applications • Follow the sequence of parameters as presented for the function set-up.
Main Menu	Allows access to all programming parameters. <ul style="list-style-type: none"> • Press twice to access top level index. • Press once to return to the last location accessed. • Press and hold to enter a parameter number for direct access to that parameter.
Alarm Log	Displays a list of current warnings, the last 10 alarms, and the maintenance log. <ul style="list-style-type: none"> • For details about the adjustable frequency drive before it entered the alarm mode, select the alarm number using the navigation keys and press [OK].

Navigation Keys

Navigation keys are used for programming functions and moving the display cursor. The navigation keys also provide speed control in local (hand) operation. Three adjustable frequency drive status indicators are also located in this area.

Figure 9-3: Navigation Keys

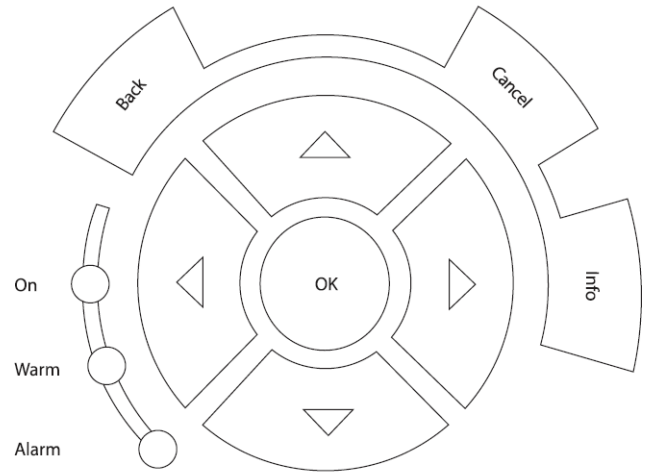

Key	Function
Back	Reverts to the previous step or list in the menu structure.
Cancel	Cancels the last change or command as long as the display mode has not changed.
Info	Press for a definition of the function being displayed.
Navigation Keys	Use the four navigation arrows to move between items in the menu.
OK	Use to access parameter groups or to enable a choice.

Light	Indicator	Function
Green	ON	The ON light activates when the adjustable frequency drive receives power from AC line voltage, a DC bus terminal, or an external 24 V supply.
Yellow	WARN	When warning conditions are met, the yellow WARN light comes on and text appears in the display area identifying the problem.
Red	ALARM	A fault condition causes the red alarm light to flash and an alarm text is displayed.

Operation Keys

Operation keys are found at the bottom of the control panel.

Figure 9-4: Operation Keys

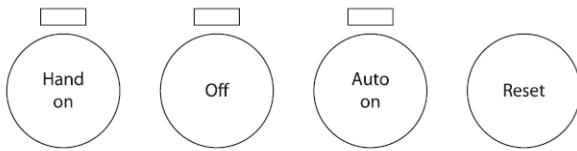

Key	Function
Hand On	Press to start the adjustable frequency drive in local control. <ul style="list-style-type: none"> • Use the navigation keys to control adjustable frequency drive speed. • An external stop signal by control input or serial communication overrides the local hand on.
Off	Stops the motor but does not remove power to the adjustable frequency drive.
Auto On	Puts the system in remote operational mode. <ul style="list-style-type: none"> • Responds to an external start command by control terminals or serial communication • Speed reference is from an external source
Reset	Resets the adjustable frequency drive manually after a fault has been cleared.

9.2 Backup and Copying Parameter Settings

Programming data is stored internally in the adjustable frequency drive.

- The data can be uploaded into the LCP memory as a storage backup.
- Once stored in the LCP, the data can be downloaded back into the adjustable frequency drive.
- Initialization of the adjustable frequency drive to restore factory default settings does not change data stored in the LCP memory.



DANGER: UNINTENDED START! When adjustable frequency drive is connected to AC line power, the motor may start at any time. The adjustable frequency drive, motor, and any driven equipment must be in operational readiness. Failure to be in operational readiness when the adjustable frequency drive is connected to AC line power could result in death, serious injury, equipment, or property damage.

7. Apply power to the unit. Default parameter settings are restored during start-up. This may take slightly

Uploading Data to the LCP

1. Press [OFF] to stop the motor before uploading or downloading data.
2. Go to *0-50 LCP Copy*.
3. Press [OK].
4. Select All to LCP.
5. Press [OK]. A progress bar shows the uploading process.
6. Press [Hand On] or [Auto On] to return to normal operation.

Downloading Data from the LCP

1. Press [OFF] to stop the motor before uploading or downloading data.
2. Go to *0-50 LCP Copy*.
3. Press [OK].
4. Select All from LCP.
5. Press [OK]. A progress bar shows the downloading process.
6. Press [Hand On] or [Auto On] to return to normal operation.

Restoring Default Settings



CAUTION: Initialization restores the unit to factory default settings. Any programming, motor data, localization, and monitoring records will be lost. Uploading data to the LCP provides a backup prior to initialization.

Restoring the adjustable frequency drive parameter settings back to default values is done by initialization of the adjustable frequency drive. Initialization can be through *14-22 Operation Mode* or manually.

- Initialization using *14-22 Operation Mode* does not change adjustable frequency drive data such as operating hours, serial communication selections, personal menu settings, fault log, alarm log, and other monitoring functions.
- Using *14-22 Operation Mode* is generally recommended.
- Manual initialization erases all motor, programming, localization, and monitoring data and restores factory default settings.

Recommended Initialization

1. Press [Main Menu] twice to access parameters.
2. Scroll to *14-22 Operation Mode*.
3. Press [OK].
4. Scroll to Initialization.
5. Press [OK].
6. Remove power to the unit and wait for the display to turn off.
 - longer than normal.
8. Press [Reset] to return to operation mode.

Manual Initialization

1. Remove power to the unit and wait for the display to turn off.
2. Press and hold [Status], [Main Menu], and [OK] at the same time and apply power to the unit.

Factory default parameter settings are restored during start-up. This may take slightly longer than normal.

Manual initialization does not reset the following adjustable frequency drive information:

- 15-00 Operating Hours
- 15-03 Power-ups
- 15-04 Over Temps
- 15-05 Over Volts

9.3 Password Protection

9.3.1 Enable Password Protection for Main Menu

1. Press [Main Menu].



2. Select 0-** Operation / Display by pressing [OK].

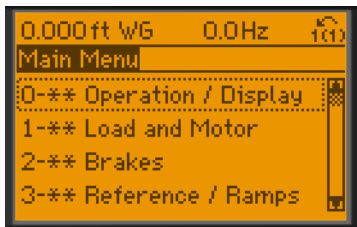

3. Scroll Down to parameter 0-6* Password.

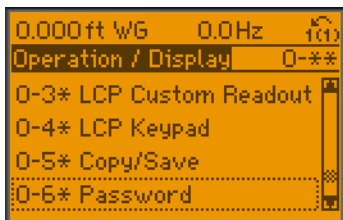

4. Press [OK].



5. Scroll down to parameter 0-61 Access to Main Menu w/o Password.



6. Press [OK].



7. Change parameter 0-61 to "[2] LCP: No Access."



8. Press [OK].



The Main Menu is now password protected. The default password is 100.

9.3.2 Disable Main Menu Password

1. Follow steps 1-6 in section 9.3.1 above.
2. Change parameter 0-61 to "[0] Full Access."



3. Press [OK].



The Main Menu Password is now disabled.

9.3.3 Change Password for Main Menu

1. Follow steps 1-4 in section 9.3.1 above.
2. Scroll down  to parameter 0-60 Main Menu Password.

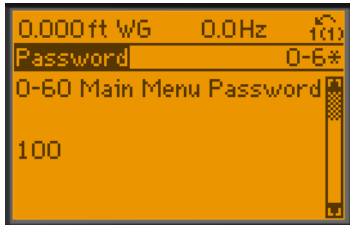

3. Press [OK].



4. Adjust/Edit the password using the arrow keys.

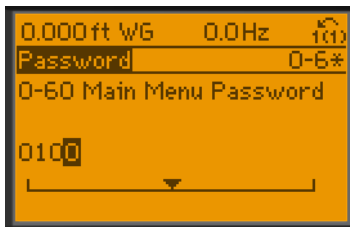

5. Press [OK].



The Main Menu password is now changed.

9.3.4 Enable Password Protection for My Personal Menu

1. Press [Main Menu].



2. Select 0-** Operation / Display by pressing [OK].

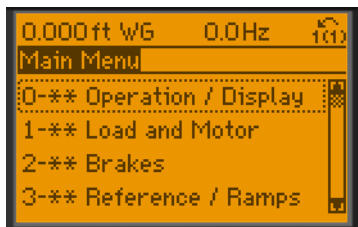

3. Scroll Down  to parameter 0-6* Password.

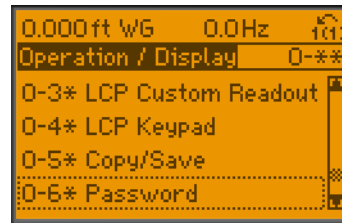

4. Press [OK].



5. Scroll down  to parameter 0-66 Access to Personal Menu w/o Password.



6. Press [OK].



7. Change parameter 0-66 to "[1] LCP: Read Only."

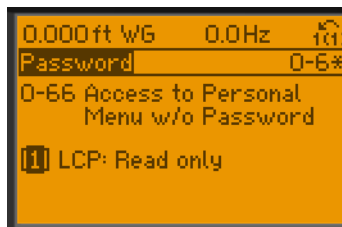

8. Press [OK].



The My Personal Menu is now password protected. The default password is 200.

9.3.5 Disable Password Protection for My Personal Menu

1. Follow steps 1-3 in in section 9.3.4 above.
2. Change parameter 0-66 to "[0] Full Access."
3. Press [OK].



The Personal Menu password protection is now disabled.

9.3.6 Change Password for Personal Menu

1. Follow steps 1-4 in section 9.3.4 above.
2. Scroll down  to parameter *0-65 Personal Menu Password*.



3. Press [OK].



4. Adjust/Edit the password using the arrow keys.

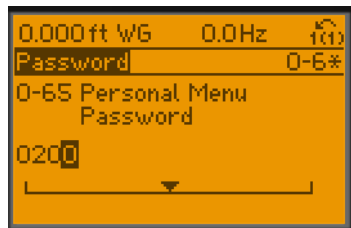

5. Press [OK].



The Personal Menu Password is now changed.

10 PUMP CONTROL SET-UPS

10.1 SelfSensing Description





The Taco SelfSensing pump is a Taco pump equipped with a variable frequency drive (VFD) with SelfSensing control technology. SelfSensing control is an innovative concept in circulating pumps. Pump performance and characteristic curves are embedded in the memory of the speed controller during manufacture. This data includes power, speed, head and flow across the flow range of the pump. During operation, the power and speed of the pump are monitored, enabling the controller to establish the hydraulic performance and position in the pumps head-flow characteristic.

These measurements enable the pump to continuously identify the head and flow at any point in time, giving accurate pressure control without the need for external feedback signals. Patented software technology within the controller ensures trouble-free operation in all conditions.

Incorporating the pump’s hydraulic data into the controller and removing sensors results in true integration of all components and removes the risk of sensor failure.

10.2 Set-up Menu

The controller has 4 different system set-ups:

Set-up	Description	Instructions
Set-up 1 	SelfSensing Variable Flow Control	Section 10.3 (Wiring: Section 8.4.2)
Set-up 2 	Standby / BAS System Input	Section 8.4.5
Set-up 3 	SelfSensing Constant Flow Control	Section 10.4 (Wiring: Section 8.4.2)
Set-up 4 	Delta P Control, 0-10V Input (Wire Pressure Transducer)	Section 8.4.3

10.2.1 Set-up Change Procedure

To change the set-up, follow the steps below.

1. If the pump is enabled, press the [Off] button and ensure the motor has stopped.



2. View the display to confirm the current set-up.



3. Press the [Quick Menu] button.



4. Press the [OK] button to enter “My Personal Menu.”



5. Scroll down  to Parameter 0-10 Active Set-up and press OK.





6. Change Active Set-up from “Set-up 1” to “Set-up 3” and press OK.

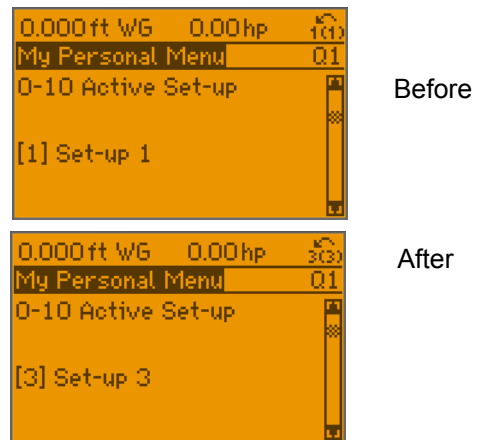

- a. Parameter 0-10 Active Set-up.



- b. You will know the change has happened when you see  change to .

10.3 Variable Flow Control (Flow Compensation)

Under Variable Flow Control (otherwise known as Flow Compensation mode), the controller is set to control the pump speed according to a 'control curve' between max and min flow (see Figure 10-1 below). This mode should be used for system distribution pumps. It is widely recognised that fitting a differential pressure sensor at the most remote load, across the supply piping and return piping encompassing the valve & coil set, is the benchmark scheme for energy efficiency.

Figure 10-1: Variable Flow Graph

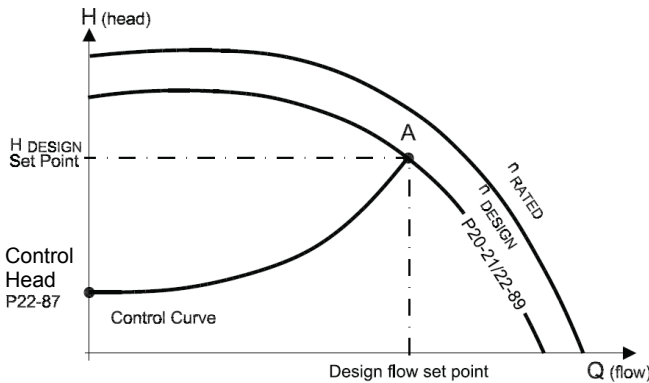

SelfSensing pumps can replicate this control without the need for the remote sensor. As the flow required by the system is reduced, the pump automatically reduces the head developed according to the pre-set control curve. In other words, the pump follows the control curve.

It is often found that using a remote differential pressure sensor to sense the pressure across a remote load could theoretically result in loads close to the pump being under-pumped. The situation would be where the load at a loop extremity is satisfied and the control valve closes while a load close to the pump needs full flow. The probability of this occurring is remote but it is possible. One answer to this is to move the sensor closer to the pump (two-thirds out in the system is a popular recommendation) although physically re-positioning the sensor at a commissioning stage can be a costly exercise. With Self-Sensing pump control it is possible to replicate the moving of a sensor by increasing the Control Head setting.

The design duty head and flow of the pump (provided at time of order) is shown as point 'A' in Figure 10-1 below.

It is not always the case that the design duty point required will fall on the maximum speed of the pump and in the majority of cases (as shown in Figure 10-1 above) it will be at a reduced speed.

The pump will be supplied with point 'A' set as the design duty point provided at the time of order and the minimum head at zero flow (Control Head) will be set as 40% of the design head ' H_{DESIGN} ' as the default.

To change the control curve from the factory settings, follow the startup procedures in "Appendix B: On-site Drive Mounting to Wall or Pump" on page 83.

10.4 Constant Flow Control

SelfSensing pumps can be configured to maintain a constant pump flow in a system. This control setting is ideal for primary systems such as boiler or chiller loops that require a constant flow.

10.4.1 For Central Plant, Constant Flow Boiler/Chiller

If this pump was ordered for a central plant constant flow boiler/chiller, you do not need to go through the balancing procedures below. Ensure the drive is already in Set-up 3 (SelfSensing Constant Flow Mode) and is therefore already self-balancing.

Figure 10-2: Constant Flow Graph

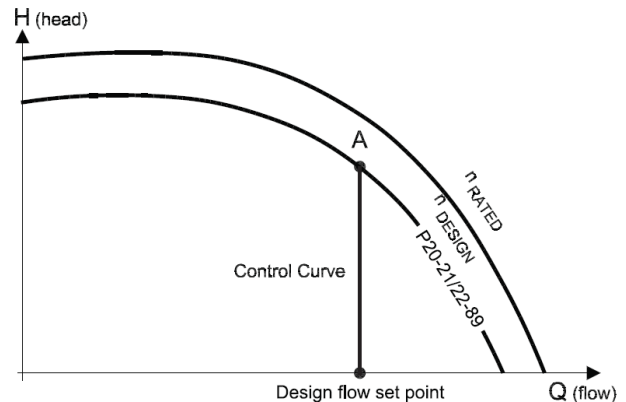

10.4.2 Settings for Constant Flow Control

To set the pump to constant flow mode and adjust the flow rate, follow steps 1-12 in section 12.3.1.

10.5 Constant Pressure Control

SelfSensing pumps can be configured to maintain a constant pump head in a system as the demand varies. This effectively simulates the mounting of a differential pressure sensor at, or near, the pump.

Figure 10-3: Constant Pressure Graph

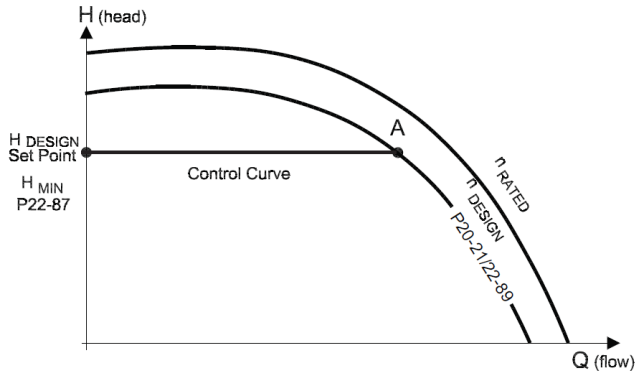

For external sequencer wiring instructions, see “8.4.5 Control from external PLC/BMS through Analog Input” on page 26.

10.5.1 Settings for Constant Pressure Control

To revert to this mode of control simply follow these steps:

1. Set the design head, H_{DESIGN} , value in par. 20-21 (Set-point 1) in the units set in par. 20-12 (Reference/Feedback Unit).
2. Turn off flow compensation by setting par. 22-80 to ‘Disabled’ [0].

10.6 Sequencing (Standby Pump Alternation)

10.6.1 Onboard Pump Sequencer

The SelfSensing pump is equipped with a built-in pump sequencer. The sequencer alternates 2 pumps back and forth according to a time interval. The factory default is 24 hours. The maximum value is 99 hours. If the duty pump has a fault or failure, the duty pump stops and the waiting pump automatically starts.

For detailed connections and settings for the pump’s onboard pump sequencer see “Appendix A: Set-Up for Standby Pump Alternation” on page 78.

10.6.2 External Pump Sequencers

The SelfSensing pump can be sequenced with external pump sequencers.

11 START-UP PROCEDURE

11.1 Check Points Before First Start

Verify that motor is correctly wired for voltage available.

Verify that the pump has been primed. The pump should never be run dry.

NOTE: Extra effort may be required to get the air out of the seal chamber.



WARNING: Make sure power supply to pump motor is locked out before touching motor shaft.

Verify that all rotating parts turn freely.

11.2 Check Motor Rotation

Before running the frequency converter, check the motor rotation. The motor will run briefly at 20Hz or the minimum frequency set in *4-12 Motor Speed Low Limit [Hz]*.

1. Check Motor rotation.
 - a. Press [Quick Menu].
 - b. Scroll to *Q2 Quick Set-up*.
 - c. Press [OK].
 - d. Scroll to *1-28 Motor Rotation Check*.
 - e. Press [OK].
 - f. Scroll to *Enable*.
 - g. The following text appears: "Note! Motor may run in wrong direction."
 - h. Press [OK].
 - i. Follow the on-screen instructions.

NOTE: To change the direction of rotation, remove power to the frequency converter and wait for power to discharge. Reverse the connection of any two of the three motor cables on the motor or frequency converter side of the connection.

11.3 Start Pump



CAUTION: MOTOR START! Ensure that the motor, system, and any attached equipment is ready for start. It is the responsibility of the user to ensure safe operation under any condition. Failure to ensure that the motor, system, and any attached equipment is ready for start could result in personal injury or equipment damage.

5. Press the [OK] button to enter "My Personal

The pump should be stopped if any of the following occur:

- No discharge.
- Insufficient discharge.
- Insufficient pressure.
- Loss of suction.
- Excessive power consumption.
- Vibration.

See "16 SKS Pump Problem Analysis" on page 74 for help in troubleshooting.

2. To navigate on the keypad, use the [OK] and [ARROW] buttons shown below.



3. Ensure the drive is in Set-up 1.



Indicates what set-up the drive is currently in.

4. To change to Set-up 1, press the [Quick Menus] button.



Menu.”



6. Scroll down  to Parameter 0-10 Active Set-up and press OK.



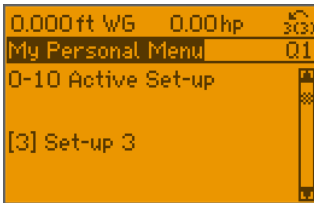

7. Change Active Set-up to “Set-up 1”.
a. Parameter 0-10 Active Set-up.

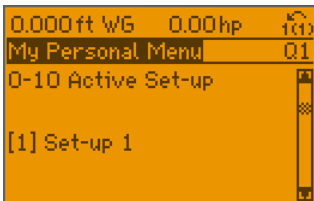

Before



After

b. You will know the change has happened when you see  change to .

8. Press the [Status] button to get back to the main screen.



9. Close the discharge valve before starting pump.



DANGER: MAKE SURE SUCTION VALVE IS OPEN!!

10. Press the [Auto on] button.



11. Once the pump has started, open the discharge valve slowly.



CAUTION: Do not operate pump for prolonged periods with discharge valve closed, to avoid overheating and potentially damaging loads.

12. After the discharge valve is fully open, let the drive ramp up to the design flow point that was specified.

IMPORTANT: Allow the pump enough time to settle out at the specified design flow.

11.4 Verify Flow

The VFD is factory programmed with the Design Pressure Head and Design VFD Speed that were indicated at the time of order.

If this pump was ordered for a system distribution pump (quadratic system curve), it ships in Set-up 1 (it will track a system control curve like the one shown in Figure 10-1).

Follow the steps below to determine whether the pump is producing the required amount of flow.

13. Close zone valves to ensure pump speed slows as demand is reduced. Then open the valves to ensure the pump increases speed until it reaches the desired flow.

14. If the pump is not meeting the desired flow conditions, as shown in the figure below, see “12 System Balancing” on page 39.

Figure 11-1: Over-sized Pump Example

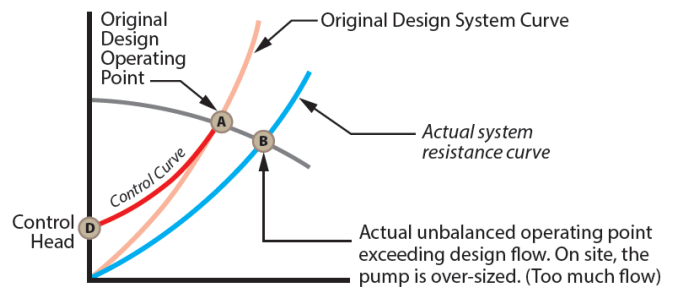

12 SYSTEM BALANCING

12.1 About SelfSensing ProBalance

The pump is equipped with SelfSensing ProBalance™ technology. SelfSensing ProBalance™ technology is a revolutionary system balancing method that utilizes the VFD's SelfSensing capabilities to enable the user to accomplish easy do-it-yourself system balancing.

This guide provides a method to reset the control curve previously discussed in Section 10.2. The goal is to move the adjusted operating point at design flow so that it falls on the actual system resistance curve (Point C in Figure 12-3).

12.1.1 A Visual Guide to Balancing

Below is a graphical guide and overview of the balancing process.

Figure 12-1: Start and Assess

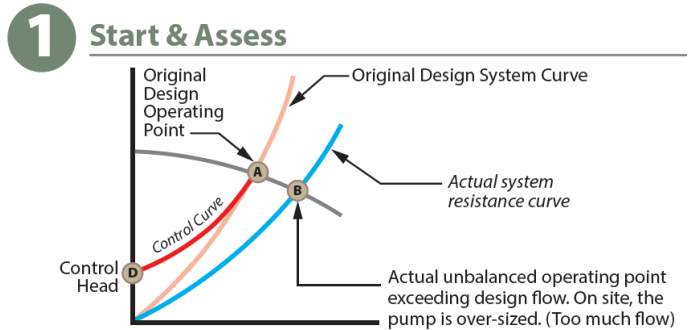

For information about the step above, see sections 11.3 and 11.4.

Figure 12-2: Measure System Resistance

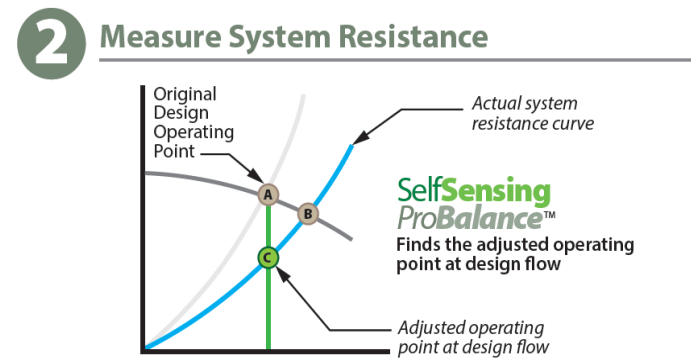

For information about the step above, see section 12.3.1.

Figure 12-3: Reset Control Curve

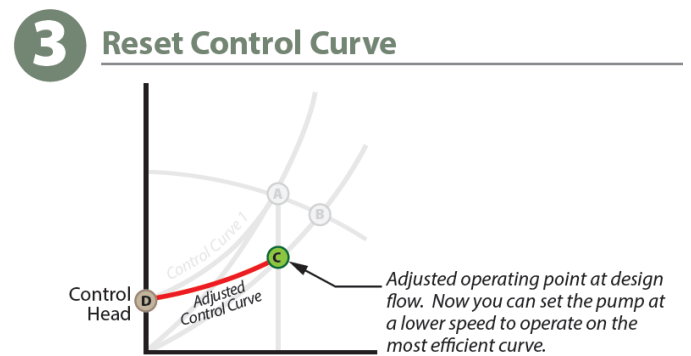

For information about the step above, see section 12.3.2.

12.2 My Personal Menu for ProBalance

The **My Personal Menu** is arranged in order to take you step by step through the SelfSensing ProBalance system balancing process.

Before you begin, it is recommended to acquaint yourself with the **My Personal Menu**.

1. Press the [Quick Menu] button.



2. My Personal Menu appears at the top of the list.



3. Press the [OK] button.



4. Press the down arrow key to scroll down the **My Personal Menu** of parameters.

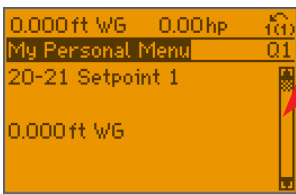

As you press the down arrow key, the scroll bar position moves down as you scroll from one parameter to the next.

5. After you arrive at the parameter you wish to adjust, press the [OK] button.



6. Use the arrow buttons to select/adjust the parameter.



7. Press [OK] when the parameter adjustment is complete.



8. Press the down arrow button  to scroll down to each consecutive parameter in the **My Personal Menu** as you follow the balancing process detailed in Section 12.3.

9. The **My Personal Menu** structure is shown below.

12.2.1 My Personal Menu Structure

Table 8: My Personal Menu

Parameter Number	Description
20-21	Set Point
22-89	Flow at Design Point
0-10	Active Set-up
20-00	Feedback 1 Source
1-00	Configuration Mode
22-86	Speed at Design Point
22-87	Pressure at No-Flow Speed
22-84	Speed at No-Flow [Hz]
20-00	Feedback 1 Source
1-00	Configuration Mode
20-12	Reference/Feedback Unit
20-60	Sensorless Unit
20-21	Set Point
13-20	SL Controller Timer
0-10	Active Set-up
22-80	Flow Compensation
22-81	Square-Linear Curve
4-14	Motor Speed High Limit [Hz]

12.3 Balancing Procedure

12.3.1 Measure System Resistance

Figure 12-4 shows a typical system response at startup. Point A is programmed at the factory per the specification/equipment schedule and the pump is set to stay on the control curve shown in Figure 12-1. However, pumps are typically oversized due to safety factor. Since the actual system resistance is too low for the pump to operate at Point A, after it reaches its max speed (typically 60hz), the pump will 'run out' to the right on the 60hz curve to Point B. The pump will then operate at Point C, which is the adjusted operating point at design flow.

Figure 12-4: Measure System Resistance

Measure System Resistance

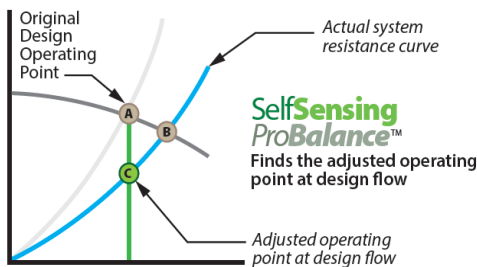

The following procedure shows how to measure the actual system resistance at the intended design flow. (Point C) This point is used later to reprogram the pump to operate along the adjusted control curve shown in Figure 12-3.

1. Ensure the system is filled and all valves are set to 100% open.
2. To navigate on the keypad use the [OK] and [ARROW] buttons shown below.



3. Press the [Off] Button.



4. Ensure the drive is in the set-up you ordered.

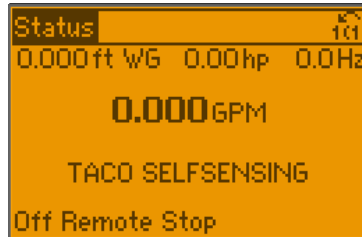

Indicates what set-up the drive is currently in.

5. Press the [Quick Menu] button.



6. Press the [OK] button to enter "My Personal Menu."



7. Scroll down  to Parameter 0-10 Active Set-up and press OK.



8. Change Active Set-up from "Set-up 1" to "Set-up 3" and press OK.



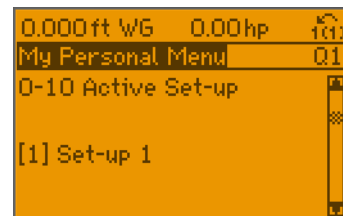

- a. Parameter 0-10 Active Set-up.

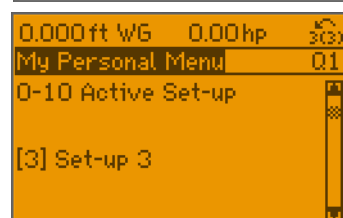

Before



After

- b. You will know the change has happened when you see  change to .

9. Scroll up  to parameter *20-21 Setpoint 1* and press OK.



10. Set the system's flow at design point (flow value that was specified at the time of order is already displayed) and press [OK].



a. Parameter 20-21 Setpoint 1.

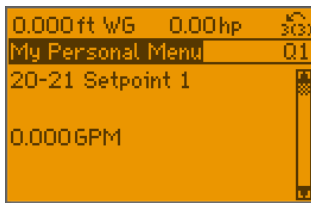

11. Press the [Auto on] button.



12. Press the [Status] button to get back to the main screen.



- a. Let the drive ramp up to the design flow point that was specified.
- b. **IMPORTANT:** Allow the pump enough time to settle out at the specified design flow.
- c. **IMPORTANT:** Record the Hz and ft WG displayed on the top of the LCD.

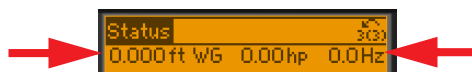

13. Press the [Off] Button.



a. Wait for the pump to come to a complete stop before moving to the next step.

12.3.2 Set Adjusted Operating Point at Design Flow

Figure 12-5: Set Control Curve Max (Point C)

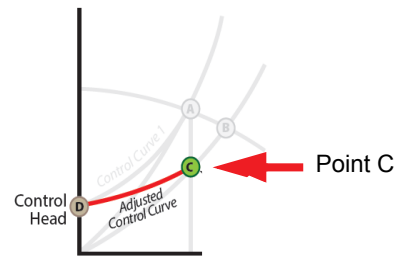

1. Press the [Quick Menu] button.



2. Press the [OK] button to enter "My Personal Menu."



3. Scroll down  to parameter *0-10 Active Set-up* and press OK.



4. Change Active Set-up from "Set-up 3" to "Set-up 1" then press OK.



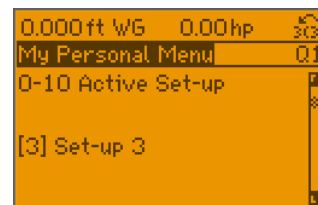

a. Parameter 0-10 Active Set-up.

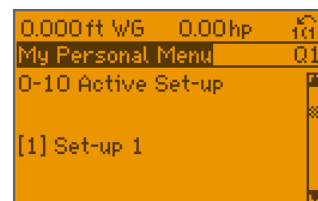

Before



After

b. You will know the change has happened when you see  change to .

5. Scroll down  to parameter *20-00 Feedback Source* and press OK.



6. Change feedback from “Sensorless Pressure” to “No function” then press OK.



a. Parameter 20-00 = Feedback 1 Source.

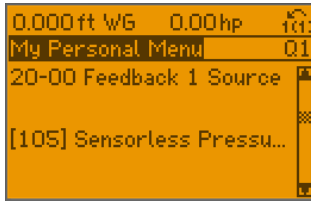

Before

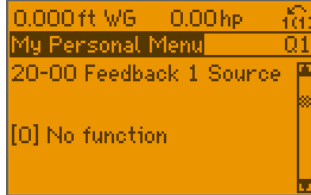

After

7. Scroll down  to parameter *1-00 Configuration Mode* and press OK.



8. Change the Configuration Mode from “Closed Loop” to “Open Loop” then press OK.



a. Parameter 1-00 = Configuration Mode.

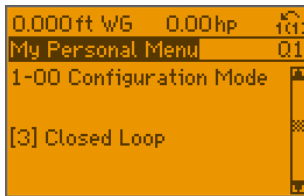

Before

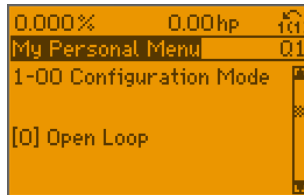

After

9. Scroll down  to parameter *22-86 Speed at Design Point* and press OK.



10. Enter the Hz you recorded in Set-up 3 (from Step 12 above) and press OK.



a. Parameter 22-86 = Speed at Design Point [Hz].

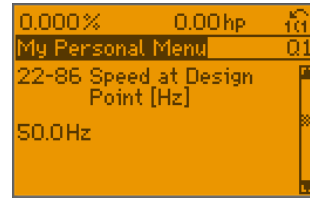

11. Scroll down  to parameter *20-00 Feedback 1 Source* and press OK.



12. Change feedback from “No function” to “Sensorless Pressure” and press OK.



a. Parameter 20-00 = Feedback 1 Source.

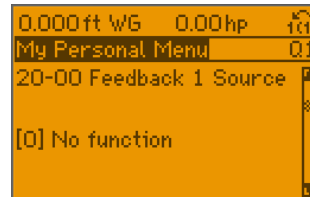

Before

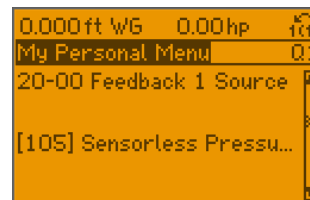

After

13. Scroll down  to parameter *1-00 Configuration Mode* and press OK.



14. Change the Configuration Mode from “Open Loop” to “Closed Loop” and press OK.



a. Parameter 1-00 = Configuration Mode.

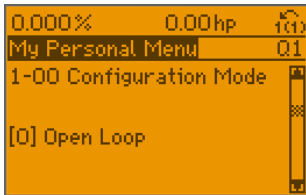

Before

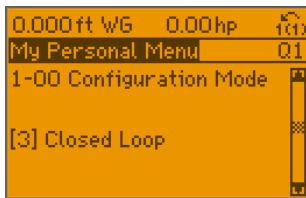

After

15. Scroll down  to parameter 20-12 Reference/Feedback Unit and press OK.



16. Change the Reference/Feedback Unit to ft WG (press the [Down Arrow] button to reach the setting faster). IMPORTANT: Due to the change in parameters, the drive will default back to metric units. It is important to set the units back to ft WG for proper function. Then press OK.



a. Parameter 20-12 = Reference/Feedback Unit to ft Wg.

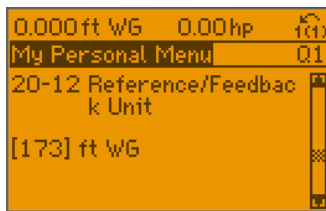

17. Scroll down  to parameter 20-60 Sensorless Unit and press OK.





18. Change Sensorless Unit to GPM (press the [Up Arrow] button to reach the setting faster). IMPORTANT: Due to the change in parameters, the drive will default back to metric units. It is important to

set the units back to GPM for proper function. Then press OK.

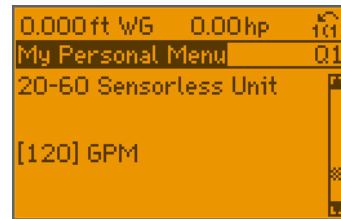

a. Parameter 20-60 = Sensorless Unit to GPM.



19. Scroll down  to parameter 20-21 Setpoint 1 and press OK.



20. Enter the Pressure Head set point (ft WG) that you previously recorded (from Step 12). Then press OK.



a. Parameter 20-21 = Setpoint 1.



21. Press the [Auto on] button to start the pump.



22. Press the [Status] button to get back to the main screen.



23. Press the [Quick Menu] button.



24. Press the [OK] button to enter "My Personal Menu."



25. Scroll down to parameter 22-89 Flow at Design Point and press OK.



a. Parameter 22-89 Flow at Design Point.

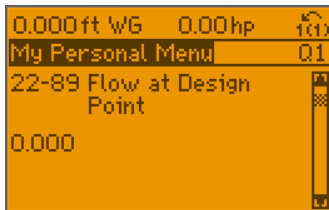

26. Press the [Status] button to get back to the main screen.



27. The programming process is now complete.

12.3.3 Set Control Head

This Step is Optional.

Follow this procedure to reset the control head (Point D). The factory default setting for Point D is 40% of the design head value (point A).

Figure 12-6: Control Head (Control Curve Minimum - Point D)

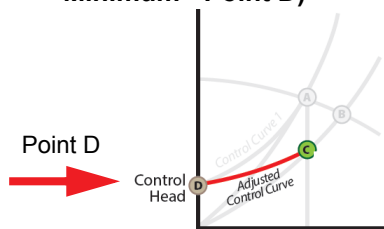

1. Press the [Off] Button.



2. Press the [Quick Menu] button.



3. Press the [OK] button to enter "My Personal Menu."



4. Scroll down to Parameter 0-10 Active Set-up and press OK.



5. Change Active Set-up from "Set-up 1" to "Set-up 3" and press OK.



a. Parameter 0-10 Active Set-up.

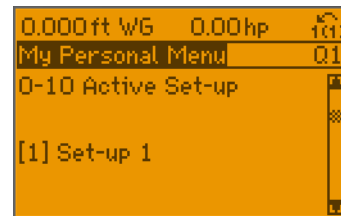

Before

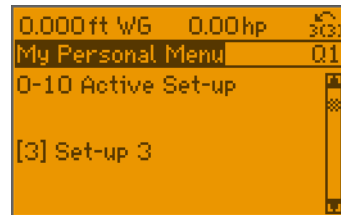

After

b. You will know the change has happened when you see change to .

6. Scroll up to parameter 20-21 Setpoint 1 and press OK.



7. Set the system's flow at design point (flow value that was specified at the time of order is already displayed) and press [OK].



a. Parameter 20-21 Setpoint 1.

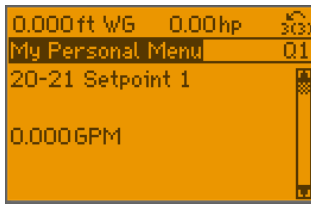

8. Press the [Auto on] button.



9. Press the [Status] button to get back to the main screen.



- a. Let the drive ramp up to the design flow point that was specified.
- b. IMPORTANT: Allow the pump enough time to settle out at the specified design flow.

10. Press the [Off] Button.



- a. Wait for the pump to come to a complete stop before moving to the next step.

11. Press the [Quick Menu] button.



12. Press the [OK] button to enter "My Personal Menu."



13. Scroll down  to parameter 0-10 Active Set-up and press OK.



14. Change Active Set-up from "Set-up 3" to "Set-up 1" then press OK.



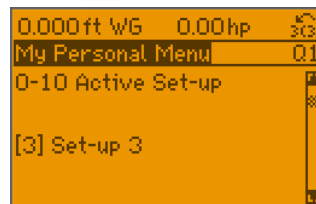

a. Parameter 0-10 Active Set-up.



Before



After

b. You will know the change has happened when you see  change to .

15. Scroll down  to parameter 20-00 Feedback Source and press OK.



16. Change feedback from "Sensorless Pressure" to "No function" then press OK.



a. Parameter 20-00 = Feedback 1 Source.

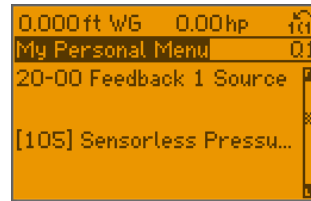

Before

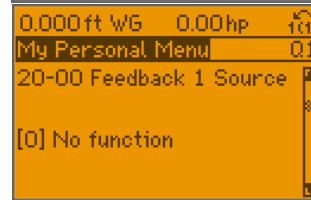

After

17. Scroll down  to parameter 1-00 Configuration Mode and press OK.



18. Change the Configuration Mode from "Closed Loop" to "Open Loop" then press OK.



a. Parameter 1-00 = Configuration Mode.

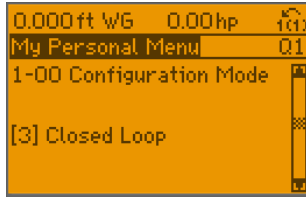

Before

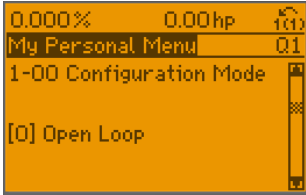

After

19. Scroll down  to parameter 22-87 *Pressure at No-Flow Speed* and press OK.



20. Set the desired Pressure at No-Flow in ft WG (Control Head) then press OK.



a. Parameter 22-87 = Pressure at No-Flow Speed.

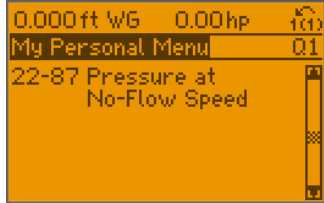

21. Scroll down  to parameter 22-84 *Speed at No-Flow* and press OK.



22. Set the VFD Speed required to produce the desired static pressure head when your system is at No-Flow conditions. The factory default is 40% of Design Pressure Head. Consult the online reference look up table for your specific pump model to determine the relationship between static head pressure and VFD Speed requirements. Then press OK.



a. Parameter 22-84 = Speed at No-Flow.

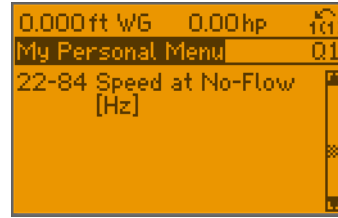

23. Scroll down  to parameter 20-00 *Feedback 1 Source* and press OK.



24. Change feedback from “No function” to “Sensorless Pressure” and press OK.



a. Parameter 20-00 = Feedback 1 Source.

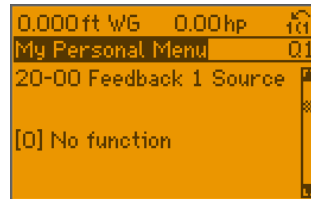

Before

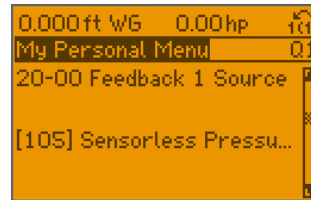

After

25. Scroll down  to parameter 1-00 *Configuration Mode* and press OK.



26. Change the Configuration Mode from “Open Loop” to “Closed Loop” and press OK.



a. Parameter 1-00 = Configuration Mode.

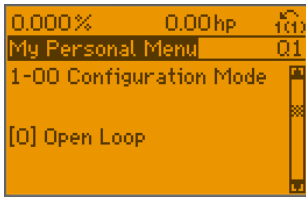

Before

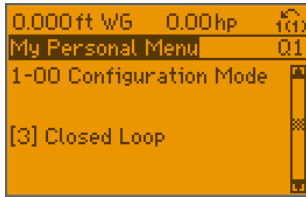

After

27. Scroll down  to parameter 20-12 Reference/Feedback Unit and press OK.



28. Change the Reference/Feedback Unit to ft WG (press the [Down Arrow] button to reach the setting faster). IMPORTANT: Due to the change in parameters, the drive will default back to metric units. It is important to set the units back to ft WG for proper function. Then press OK.



a. Parameter 20-12 = Reference/Feedback Unit to ft Wg.

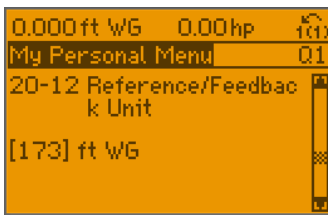

29. Scroll down  to parameter 20-60 Sensorless Unit and press OK.



30. Change Sensorless Unit to GPM (press the [Up Arrow] button to reach the setting faster). IMPORTANT: Due to the change in parameters, the drive will default back to metric units. It is important to set the units back to GPM for proper function. Then press OK.



a. Parameter 20-60 = Sensorless Unit to GPM.



31. Press the [Auto on] button to start the pump.



32. Press the [Status] button to get back to the main screen.



33. The programming process is now complete and you can run the drive.

12.3.4 Flow Fine Tuning

After balancing is complete, if the flow at Point C requires fine tuning, simply increase or decrease Parameter 20-21 *Setpoint 1* until desired flow is achieved. Follow this procedure to adjust the setpoint.

1. Press the [Quick Menu] button.



2. Press the [OK] button to enter "My Personal Menu."



3. Scroll down  to parameter 20-21 *Setpoint 1* and press OK.



4. Enter the Pressure Head set point (ft WG) that will achieve the desired flow. Then press OK.



- a. Parameter 20-21 = Setpoint 1.



5. Press the [Auto on] button to start the pump.



6. Press the [Status] button to get back to the main screen.



12.4 Additional Settings

Other settings that are set to enable the pump to operate on a control curve are:

- Par. 22-80 (*Flow Compensation*), which should be set to 'Enabled' [1]

- Par 22-81 (*Square-linear Curve Approximation*), which should be set to '100%'.

Figure 12-7: Curve Approximation Settings

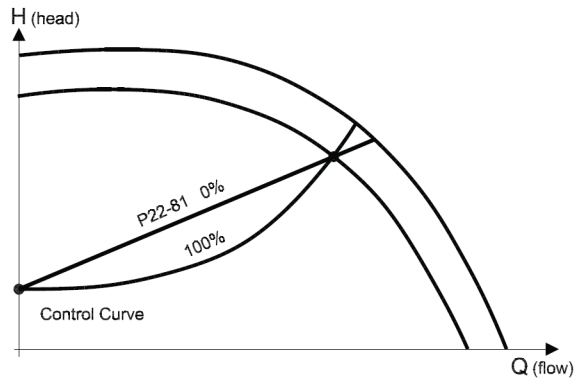

The effect of adjusting par. 22-81 is shown in Figure 12-7 above. A setting of 100% gives the ideal theoretical control curve between the design head and minimum head while 0% provides a straight line linear approximation.

13 MENUS

13.0.1 Quick Menu Structure - page 1

Q3-1 General Settings	0-24 Display Line 3 Large	1-00 Configuration Mode	Q3-31 Single Zone Ext. Setpoint	20-70 Closed-loop Type
Q3-10 Adv. Motor Settings	0-37 Display Text 1	20-12 Reference/Feedback Unit	1-00 Configuration Mode	20-71 PID Performance
1-90 Motor Thermal Protection	0-38 Display Text 2	20-13 Minimum Reference/Feedb.	20-12 Reference/Feedback Unit	20-72 PID Output Change
1-93 Thermistor Source	0-39 Display Text 3	20-14 Maximum Reference/Feedb.	20-13 Minimum Reference/Feedb.	20-73 Minimum Feedback Level
1-29 Automatic Motor Adaptation (AMIA)	Q3-2 Open-loop Settings	6-22 Terminal 54 Low Current	20-14 Maximum Reference/Feedb.	20-74 Maximum Feedback Level
14-01 Switching Frequency	Q3-20 Digital Reference	6-24 Terminal 54 Low Ref./Feedb. Value	6-10 Terminal 53 Low Voltage	20-79 PID Autotuning
4-53 Warning Speed High	3-02 Minimum Reference	6-25 Terminal 54 High Ref./Feedb. Value	6-11 Terminal 53 High Voltage	Q3-32 Multi Zone / Adv
Q3-11 Analog Output	3-03 Maximum Reference	6-26 Terminal 54 Filter Time Constant	6-12 Terminal 53 Low Current	1-00 Configuration Mode
6-50 Terminal 42 Output	3-10 Preset Reference	6-27 Terminal 54 Live Zero	6-13 Terminal 53 High Current	3-15 Reference 1 Source
6-51 Terminal 42 Output Min Scale	5-13 Terminal 29 Digital Input	6-00 Live Zero Timeout Time	6-14 Terminal 53 Low Ref./Feedb. Value	3-16 Reference 2 Source
6-52 Terminal 42 Output Max Scale	5-14 Terminal 32 Digital Input	6-01 Live Zero Timeout Function	6-15 Terminal 53 High Ref./Feedb. Value	20-00 Feedback 1 Source
Q3-12 Clock Settings	5-15 Terminal 33 Digital Input	20-21 Setpoint 1	6-22 Terminal 54 Low Current	20-01 Feedback 1 Conversion
0-70 Date and Time	Q3-21 Analog Reference	20-81 PID Normal/ Inverse Control	6-24 Terminal 54 Low Ref./Feedb. Value	20-02 Feedback 1 Source Unit
0-71 Date Format	3-02 Minimum Reference	20-82 PID Start Speed [RPM]	6-25 Terminal 54 High Ref./Feedb. Value	20-03 Feedback 2 Source
0-72 Time Format	3-03 Maximum Reference	20-83 PID Start Speed [Hz]	6-26 Terminal 54 Filter Time Constant	20-04 Feedback 2 Conversion
0-74 DST/Summertime	6-10 Terminal 53 Low Voltage	20-93 PID Proportional Gain	6-27 Terminal 54 Live Zero	20-05 Feedback 2 Source Unit
0-76 DST/Summertime Start	6-11 Terminal 53 High Voltage	20-94 PID Integral Time	6-00 Live Zero Timeout Time	20-06 Feedback 3 Source
0-77 DST/Summertime End	6-12 Terminal 53 Low Current	20-70 Closed-loop Type	6-01 Live Zero Timeout Function	20-07 Feedback 3 Conversion
Q3-13 Display Settings	6-13 Terminal 53 High Current	20-71 PID Performance	20-81 PID Normal/ Inverse Control	20-08 Feedback 3 Source Unit
0-20 Display Line 1.1 Small	6-14 Terminal 53 Low Ref./Feedb. Value	20-72 PID Output Change	20-82 PID Start Speed [RPM]	20-12 Reference/Feedback Unit

13.0.2 Quick Menu Structure - page 2

0-21 Display Line 1.2 Small	6-15 Terminal 53 High Ref./ Feedb. Value	20-73 Minimum Feedback Level	20-83 PID Start Speed [Hz]	20-13 Minimum Reference/ Feedb.
0-22 Display Line 1.3 Small	Q3-3 Closed-loop Settings	20-74 Maximum Feedback Level	20-93 PID Proportional Gain	20-14 Maximum Reference/ Feedb.
0-23 Display Line 2 Large	Q3-30 Single Zone Int. Set- point	20-79 PID Autotuning	20-94 PID Integral Time	6-10 Terminal 53 Low Voltage
6-11 Terminal 53 High Voltage	20-21 Setpoint 1	22-22 Low Speed Detection	22-21 Low Power Detection	22-87 Pressure at No-Flow Speed
6-12 Terminal 53 Low Current	20-22 Setpoint 2	22-23 No-Flow Function	22-22 Low Speed Detection	22-88 Pressure at Rated Speed
6-13 Terminal 53 High Current	20-81 PID Normal/ Inverse Control	22-24 No-Flow Delay	22-23 No-Flow Function	22-89 Flow at Design Point
6-14 Terminal 53 Low Ref./ Feedb. Value	20-82 PID Start Speed [RPM]	22-40 Minimum Run Time	22-24 No-Flow Delay	22-90 Flow at Rated Speed
6-15 Terminal 53 High Ref./ Feedb. Value	20-83 PID Start Speed [Hz]	22-41 Minimum Sleep Time	22-40 Minimum Run Time	1-03 Torque Characteristics
6-16 Terminal 53 Filter Time Con- stant	20-93 PID Proportional Gain	22-42 Wake-up Speed [RPM]	22-41 Minimum Sleep Time	1-73 Flying Start
6-17 Terminal 53 Live Zero	20-94 PID Integral Time	22-43 Wake-up Speed [Hz]	22-42 Wake-up Speed [RPM]	Q3-42 Compressor Functions
6-20 Terminal 54 Low Voltage	20-70 Closed-loop Type	22-44 Wake-up Ref./FB Dif- ference	22-43 Wake-up Speed [Hz]	1-03 Torque Characteristics
6-21 Terminal 54 High Voltage	20-71 PID Performance	22-45 Setpoint Boost	22-44 Wake-up Ref./FB Differ- ence	1-71 Start Delay
6-22 Terminal 54 Low Current	20-72 PID Output Change	22-46 Maximum Boost Time	22-45 Setpoint Boost	22-75 Short Cycle Protection
6-23 Terminal 54 High Current	20-73 Minimum Feedback Level	2-10 Brake Function	22-46 Maximum Boost Time	22-76 Interval between Starts
6-24 Terminal 54 Low Ref./ Feedb. Value	20-74 Maximum Feedback Level	2-16 AC Brake Max. Current	22-26 Dry Pump Function	22-77 Minimum Run Time
6-25 Terminal 54 High Ref./ Feedb. Value	20-79 PID Autotuning	2-17 Over-voltage Control	22-27 Dry Pump Delay	5-01 Terminal 27 Mode
6-26 Terminal 54 Filter Time Con- stant	Q3-4 Application Settings	1-73 Flying Start	22-80 Flow Compensation	5-02 Terminal 29 Mode
6-27 Terminal 54 Live Zero	Q3-40 Fan Functions	1-71 Start Delay	22-81 Square-linear Curve Approximation	5-12 Terminal 27 Digital Input
6-00 Live Zero Timeout Time	22-60 Broken Belt Function	1-80 Function at Stop	22-82 Work Point Calculation	5-13 Terminal 29 Digital Input
6-01 Live Zero Timeout Function	22-61 Broken Belt Torque	2-00 DC Hold/Preheat Cur- rent	22-83 Speed at No-Flow [RPM]	5-40 Function Relay
4-56 Warning Feedback Low	22-62 Broken Belt Delay	4-10 Motor Speed Direction	22-84 Speed at No-Flow [Hz]	1-73 Flying Start
4-57 Warning Feedback High	4-64 Semi-Auto Bypass Set- up	Q3-41 Pump Functions	22-85 Speed at Design Point [RPM]	1-86 Trip Speed Low [RPM]
20-20 Feedback Function	1-03 Torque Characteristics	22-20 Low Power Auto Set- up	22-86 Speed at Design Point [Hz]	1-87 Trip Speed Low [Hz]

13.0.3 Main Menu Structure - page 1

0-** Operation / Display	0-37 Display Text 1	0-77 DST/Summertime End	1-36 Iron Loss Resistance (Rfe)	1-82 Min Speed for Function at Stop [Hz]
0-0* Basic Settings	0-38 Display Text 2	0-79 Clock Fault	1-39 Motor Poles	1-86 Trip Speed Low [RPM]
0-01 Language	0-39 Display Text 3	0-81 Working Days	1-5* Load-Indep. Setting	1-87 Trip Speed Low [Hz]
0-02 Motor Speed Unit	0-4* LCP Keypad	0-82 Additional Working Days	1-50 Motor Magnetization at Zero Speed	1-9* Motor Temperature
0-03 Regional Settings	0-40 [Hand on] Key on LCP	0-83 Additional Non-Working Days	1-51 Min Speed Normal Magnetizing [RPM]	1-90 Motor Thermal Protection
0-04 Operating State at Power-up	0-41 [Off] Key on LCP	0-89 Date and Time Readout	1-52 Min Speed Normal Magnetizing [Hz]	1-91 Motor External Fan
0-05 Local Mode Unit	0-42 [Auto on] Key on LCP	1-** Load and Motor	1-58 Flystart Test Pulses Current	1-93 Thermistor Source
0-1* Set-up Operations	0-43 [Reset] Key on LCP	1-0* General Settings	1-59 Flystart Test Pulses Frequency	2-** Brakes
0-10 Active Set-up	0-44 [Off/Reset] Key on LCP	1-00 Configuration Mode	1-6* Load-Depend. Settg.	2-0* DC Brake
0-11 Programming Set-up	0-45 [Drive Bypass] Key on LCP	1-03 Torque Characteristics	1-60 Low Speed Load Compensation	2-00 DC Hold/Preheat Current
0-12 This Set-up Linked to	0-5* Copy/Save	1-06 Clockwise Direction	1-61 High Speed Load Compensation	2-01 DC Brake Current
0-13 Readout: Linked Set-ups	0-50 LCP Copy	1-2* Motor Data	1-62 Slip Compensation	2-02 DC Braking Time
0-14 Readout: Prog. Set-ups / Channel	0-51 Set-up Copy	1-20 Motor Power [kW]	1-63 Slip Compensation Time Constant	2-03 DC Brake Cut-in Speed [RPM]
0-2* LCP Display	0-6* Password	1-21 Motor Power [HP]	1-64 Resonance Dampening Time Constant	2-1* Brake Energy Funct.
0-20 Display Line 1.1 Small	0-60 Main Menu Password	1-22 Motor Voltage	1-7* Start Adjustments	2-10 Brake Function
0-21 Display Line 1.2 Small	0-61 Access to Main Menu w/o Password	1-23 Motor Frequency	1-71 Start Delay	2-11 Brake Resistor (ohm)
0-22 Display Line 1.3 Small	0-65 Personal Menu Password	1-24 Motor Current	1-73 Flying Start	2-12 Brake Power Limit (kW)
0-23 Display Line 2 Large	0-66 Access to Personal Menu w/o Password	1-25 Motor Nominal Speed	1-77 Compressor Start Max Speed [RPM]	2-13 Brake Power Monitoring
0-24 Display Line 3 Large	0-7* Clock Settings	1-28 Motor Rotation Check	1-78 Compressor Start Max Speed [Hz]	2-15 Brake Check
0-25 My Personal Menu	0-70 Date and Time	1-29 Automatic Motor Adaptation (AMA)	1-79 Compressor Start Max Time to Trip	2-16 AC Brake Max. Current
0-3* LCP Cust. Readout	0-71 Date Format	1-3* Addl. Motor Data	1-8* Stop Adjustments	3-** Reference / Ramps
0-30 Custom Readout Unit	0-72 Time Format	1-30 Stator Resistance (Rs)	1-80 Function at Stop	
0-31 Custom Readout Min Value	0-74 DST/Summertime	1-31 Rotor Resistance (Rr)		

13.0.4 Main Menu Structure - page 2

0-32 Custom Readout Max Value	0-76 DST/Summertime Start	1-35 Main Reactance (Xh)	1-81 Min Speed for Function at Stop [RPM]	3-0* Reference Limits
3-02 Minimum Reference	3-92 Power Restore	4-6* Speed Bypass	5-33 Term X30/7 Digi Out (MCB 101)	5-93 Pulse Out #27 Bus Control
3-03 Maximum Reference	3-93 Maximum Limit	4-60 Bypass Speed From [RPM]	5-4* Relays	5-94 Pulse Out #27 Timeout Pre-set
3-04 Reference Function	3-94 Minimum Limit	4-61 Bypass Speed From [Hz]	5-40 Function Relay	5-95 Pulse Out #29 Bus Control
3-1* References	3-95 Ramp Delay	4-62 Bypass Speed to [RPM]	5-41 On Delay, Relay	5-96 Pulse Out #29 Timeout Pre-set
3-10 Preset Reference	4-** Limits / Warnings	4-63 Bypass Speed To [Hz]	5-42 Off Delay, Relay	5-97 Pulse Out #X30/6 Bus Control
3-11 Jog Speed [Hz]	4-1* Motor Limits	4-64 Semi-Auto Bypass Setup	5-5* Pulse Input	5-98 Pulse Out #X30/6 Timeout Preset
3-13 Reference Site	4-10 Motor Speed Direction	5-** Digital In/Out	5-50 Term. 29 Low Frequency	6-** Analog In/Out
3-14 Preset Relative Reference	4-11 Motor Speed Low Limit [RPM]	5-0* Digital I/O mode	5-51 Term. 29 High Frequency	6-0* Analog I/O Mode
3-15 Reference 1 Source	4-12 Motor Speed Low Limit [Hz]	5-00 Digital I/O Mode	5-52 Term. 29 Low Ref./Feedb. Value	6-00 Live Zero Timeout Time
3-16 Reference 2 Source	4-13 Motor Speed High Limit [RPM]	5-01 Terminal 27 Mode	5-53 Term. 29 High Ref./Feedb. Value	6-01 Live Zero Timeout Function
3-17 Reference 3 Source	4-14 Motor Speed High Limit [Hz]	5-02 Terminal 29 Mode	5-54 Pulse Filter Time Constant #29	6-02 Fire Mode Live Zero Timeout Function
3-19 Jog Speed [RPM]	4-16 Torque Limit Motor Mode	5-1* Digital Inputs	5-55 Term. 33 Low Frequency	6-1* Analog Input 53
3-4* Ramp 1	4-17 Torque Limit Generator Mode	5-10 Terminal 18 Digital Input	5-56 Term. 33 High Frequency	6-10 Terminal 53 Low Voltage
3-41 Ramp 1 Ramp-up Time	4-18 Current Limit	5-11 Terminal 19 Digital Input	5-57 Term. 33 Low Ref./Feedb. Value	6-11 Terminal 53 High Voltage
3-42 Ramp 1 Ramp-down Time	4-19 Max Output Frequency	5-12 Terminal 27 Digital Input	5-58 Term. 33 High Ref./Feedb. Value	6-12 Terminal 53 Low Current
3-5* Ramp 2	4-5* Adj. Warnings	5-13 Terminal 29 Digital Input	5-59 Pulse Filter Time Constant #33	6-13 Terminal 53 High Current
3-51 Ramp 2 Ramp-up Time	4-50 Warning Current Low	5-14 Terminal 32 Digital Input	5-6* Pulse Output	6-14 Terminal 53 Low Ref./Feedb. Value
3-52 Ramp 2 Ramp-down Time	4-51 Warning Current High	5-15 Terminal 33 Digital Input	5-60 Terminal 27 Pulse Output Variable	6-15 Terminal 53 High Ref./Feedb. Value
3-8* Other Ramps	4-52 Warning Speed Low	5-16 Terminal X30/2 Digital Input	5-62 Pulse Output Max Freq #27	6-16 Terminal 53 Filter Time Constant
3-80 Jog Ramp Time	4-53 Warning Speed High	5-17 Terminal X30/3 Digital Input	5-63 Terminal 29 Pulse Output Variable	6-17 Terminal 53 Live Zero

13.0.5 Main Menu Structure - page 3

3-81 Quick Stop Ramp Time	4-54 Warning Reference Low	5-18 Terminal X30/4 Digital Input	5-65 Pulse Output Max Freq #29	6-2* Analog Input 54
3-82 Starting Ramp Up Time	4-55 Warning Reference High	5-3* Digital Outputs	5-66 Terminal X30/6 Pulse Output Variable	6-20 Terminal 54 Low Voltage
3-9* Digital Pot. meter	4-56 Warning Feedback Low	5-30 Terminal 27 Digital Output	5-68 Pulse Output Max Freq #X30/6	6-21 Terminal 54 High Voltage
3-90 Step Size	4-57 Warning Feedback High	5-31 Terminal 29 Digital Output	5-9* Bus Controlled	6-22 Terminal 54 Low Current
3-91 Ramp Time	4-58 Missing Motor Phase Function	5-32 Term X30/6 Digi Out (MCB 101)	5-90 Digital & Relay Bus Control	6-23 Terminal 54 High Current
6-24 Terminal 54 Low Ref./ Feeds. Value	6-64 Terminal X30/8 Output Timeout Preset	8-52 DC Brake Select	9-16 PCD Read Configuration	10-** CAN Fieldbus
6-25 Terminal 54 High Ref./ Feeds. Value	8-** Comm. and Options	8-53 Start Select	9-18 Node Address	10-0* Common Settings
6-26 Terminal 54 Filter Time Constant	8-0* General Settings	8-54 Reversing Select	9-22 Telegram Selection	10-00 CAN Protocol
6-27 Terminal 54 Live Zero	8-01 Control Site	8-55 Set-up Select	9-23 Parameters for Signals	10-01 Baud Rate Select
6-3* Analog Input X30/11	8-02 Control Source	8-56 Preset Reference Select	9-27 Parameter Edit	10-02 MAC ID
6-30 Terminal X30/11 Low Voltage	8-03 Control Timeout Time	8-7* BACnet	9-28 Process Control	10-05 Readout Transmit Error Counter
6-31 Terminal X30/11 High Voltage	8-04 Control Timeout Function	8-70 BACnet Device Instance	9-44 Fault Message Counter	10-06 Readout Receive Error Counter
6-34 Term. X30/11 Low Ref./ Feeds. Value	8-05 End-of-Timeout Function	8-72 MS/TP Max Masters	9-45 Fault Code	10-07 Readout Bus Off Counter
6-35 Term. X30/11 High Ref./ Feeds. Value	8-06 Reset Control Timeout	8-73 MS/TP Max Info Frames	9-47 Fault Number	10-1* DeviceNet
6-36 Term. X30/11 Filter Time Constant	8-07 Diagnosis Trigger	8-74 "I-Am" Service	9-52 Fault Situation Counter	10-10 Process Data Type Selection
6-37 Term. X30/11 Live Zero	8-08 Readout Filtering	8-75 Initialization Password	9-53 Profibus Warning Word	10-11 Process Data Confg Write
6-4* Analog Input X30/12	8-1* Control Settings	8-8* FC Port Diagnostics	9-63 Actual Baud Rate	10-12 Process Data Confg Read
6-40 Terminal X30/12 Low Voltage	8-10 Control Profile	8-80 Bus Message Count	9-64 Device Identification	10-13 Warning Parameter
6-41 Terminal X30/12 High Voltage	8-13 Configurable Status Word STW	8-81 Bus Error Count	9-65 Profile Number	10-14 Net Reference
6-44 Term. X30/12 Low Ref./ Feeds. Value	8-3* FC Port Settings	8-82 Slave Messages Rcvd	9-67 Control Word 1	10-15 Net Control
6-45 Term. X30/12 High Ref./ Feeds. Value	8-30 Protocol	8-83 Slave Error Count	9-68 Status Word 1	10-2* COS Filters
6-46 Term. X30/12 Filter Time Constant	8-31 Address	8-84 Slave Messages Sent	9-70 Programming Set-up	10-20 COS Filter 1

13.0.6 Main Menu Structure - page 4

6-47 Term. X30/12 Live Zero	8-32 Baud Rate	8-85 Slave Timeout Errors	9-71 Profibus Save Data Values	10-21 COS Filter 2
6-5* Analog Output	42 8-33 Parity / Stop Bits	8-89 Diagnostics Count	9-72 Profibus DriveReset	10-22 COS Filter 3
6-50 Terminal 42 Output	8-34 Estimated cycle time	8-9* Bus Jog / Feedback	9-80 Defined Parameters (1)	10-23 COS Filter 4
6-51 Terminal 42 Output Min Scale	8-35 Minimum Response Delay	8-90 Bus Jog 1 Speed	9-81 Defined Parameters (2)	10-3* Parameter Access
6-52 Terminal 42 Output Max Scale	8-36 Maximum Response Delay	8-91 Bus Jog 2 Speed	9-82 Defined Parameters (3)	10-30 Array Index
6-53 Terminal 42 Output Bus Control	8-37 Maximum Inter-Char Delay	8-94 Bus Feedback 1	9-83 Defined Parameters (4)	10-31 Store Data Values
6-54 Terminal 42 Output Time-out Preset	8-4* FC MC protocol set	8-95 Bus Feedback 2	9-84 Defined Parameters (5)	10-32 Devicenet Revision
6-6* Analog Output X30/8	8-40 Telegram selection	8-96 Bus Feedback 3	9-90 Changed Parameters (1)	10-33 Store Always
6-60 Terminal X30/8 Output	8-42 PCD write configuration	9-** Profibus	9-91 Changed Parameters (2)	10-34 DeviceNet Product Code
6-61 Terminal X30/8 Min. Scale	8-43 PCD read configuration	9-00 Setpoint	9-92 Changed Parameters (3)	10-39 Devicenet F Parameters
6-62 Terminal X30/8 Max. Scale	8-5* Digital/Bus	9-07 Actual Value	9-93 Changed Parameters (4)	11-** LonWorks
6-63 Terminal X30/8 Output Bus Control	8-50 Coasting Select	9-15 PCD Write Configuration	9-94 Changed parameters (5)	11-0* LonWorks ID
11-00 Neuron ID	14-** Special Functions	14-50 RFI Filter	15-23 Historic Log: Date and Time	15-72 Option in Slot B
11-1* LON Functions	14-0* Inverter Switching	14-51 DC Link Compensation	15-3* Alarm Log	15-73 Slot B Option SW Version
11-10 Drive Profile	14-00 Switching Pattern	14-52 Fan Control	15-30 Alarm Log: Error Code	15-74 Option in Slot C0
11-15 LON Warning Word	14-01 Switching Frequency	14-53 Fan Monitor	15-31 Alarm Log: Value	15-75 Slot C0 Option SW Version
11-17 XIF Revision	14-03 Overmodulation	14-6* Auto Derate	15-32 Alarm Log: Time	15-76 Option in Slot C1
11-18 LonWorks Revision	14-04 PWM Random	14-60 Function at Overtemperature	15-33 Alarm Log: Date and Time	15-77 Slot C1 Option SW Version
11-2* LON Param. Access	14-1* Mains On/Off	14-61 Function at Inverter Overload	15-4* Drive Identification	15-9* Parameter Info
11-21 Store Data Values	14-10 Mains Failure	14-62 Inv. Overload Derate Current	15-40 FC Type	15-92 Defined Parameters
13-** Smart Logic	14-11 Mains Voltage at Mains Fault	15-** Drive Information	15-41 Power Section	15-93 Modified Parameters
13-0* SLC Settings	14-12 Function at Mains Imbalance	15-0* Operating Data	15-42 Voltage	15-98 Drive Identification
13-00 SL Controller Mode	14-2* Reset Functions	15-00 Operating Hours	15-43 Software Version	15-99 Parameter Metadata
13-01 Start Event	14-20 Reset Mode	15-01 Running Hours	15-44 Ordered Typecode String	16-** Data Readouts
13-02 Stop Event	14-21 Automatic Restart Time	15-02 kWh Counter	15-45 Actual Typecode String	16-0* General Status
13-03 Reset SLC	14-22 Operation Mode	15-03 Power-ups	15-46 Adjustable Frequency Drive Ordering No	16-00 Control Word

13.0.7 Main Menu Structure - page 5

13-1* Comparators	14-23 Typecode Setting	15-04 Overtemps	15-47 Power Card Ordering No	16-01 Reference [Unit]
13-10 Comparator Operand	14-25 Trip Delay at Torque Limit	15-05 Overvolts	15-48 LCP Id No	16-02 Reference [%]
13-11 Comparator Operator	14-26 Trip Delay at Inverter Fault	15-06 Reset kWh Counter	15-49 SW ID Control Card	16-03 Status Word
13-12 Comparator Value	14-28 Production Settings	15-07 Reset Running Hours Counter	15-50 SW ID Power Card	16-05 Main Actual Value [%]
13-2* Timers	14-29 Service Code	15-08 Number of Starts	15-51 Adj. Frequency Drive Serial Number	16-09 Custom Readout
13-20 SL Controller Timer	14-3* Current Limit Ctrl.	15-1* Data Log Settings	15-53 Power Card Serial Number	16-1* Motor Status
13-4* Logic Rules	14-30 Current Lim Ctrl, Proportional Gain	15-10 Logging Source	15-55 Vendor URL	16-10 Power [kW]
13-40 Logic Rule Boolean 1	14-31 Current Lim Ctrl, Integration Time	15-11 Logging Interval	15-56 Vendor Name	16-11 Power [hp]
13-41 Logic Rule Operator 1	14-32 Current Lim Ctrl, Filter Time	15-12 Trigger Event	15-6* Option Ident	16-12 Motor Voltage
13-42 Logic Rule Boolean 2	14-4* Energy Optimizing	15-13 Logging Mode	15-60 Option Mounted	16-13 Frequency
13-43 Logic Rule Operator 2	14-40 VT Level	15-14 Samples Before Trigger	15-61 Option SW Version	16-14 Motor Current
13-44 Logic Rule Boolean 3	14-41 AEO Minimum Magnetization	15-2* Historic Log	15-62 Option Ordering No	16-15 Frequency [%]
13-5* States	14-42 Minimum AEO Frequency	15-20 Historic Log: Event	15-63 Option Serial No	16-16 Torque [Nm]
13-51 SL Controller Event	14-43 Motor Cosphi	15-21 Historic Log: Value	15-70 Option in Slot A	16-17 Speed [RPM]
13-52 SL Controller Action	14-5* Environment	15-22 Historic Log: Time	15-71 Slot A Option SW Version	16-18 Motor Thermal
16-22 Torque [%]	16-66 Digital Output [bin]	18-1* Fire Mode Log	20-14 Maximum Reference/Feedb.	20-84 On Reference Bandwidth
16-26 Power Filtered [kW]	16-67 Pulse Input #29 [Hz]	18-10 Fire Mode Log: Event	20-2* Feedback/Setpoint	20-9* PID Controller
16-27 Power Filtered [hp]	16-68 Pulse Input #33 [Hz]	18-11 Fire Mode Log: Time	20-20 Feedback Function	20-91 PID Anti Windup
16-3* Drive Status	16-69 Pulse Output #27 [Hz]	18-12 Fire Mode Log: Date and Time	20-21 Setpoint 1	20-93 PID Proportional Gain
16-30 DC Link Voltage	16-70 Pulse Output #29 [Hz]	18-3* Inputs & Outputs	20-22 Setpoint 2	20-94 PID Integral Time
16-32 Brake Energy /s	16-71 Relay Output [bin]	18-30 Analog Input X42/1	20-23 Setpoint 3	20-95 PID Differentiation Time
16-33 Brake Energy /2 min	16-72 Counter A	18-31 Analog Input X42/3	20-3* Feedb. Adv. Conv.	20-96 PID Diff. Gain Limit
16-34 Heatsink Temp.	16-73 Counter B	18-32 Analog Input X42/5	20-30 Refrigerant	21-** Ext. Closed-loop
16-36 Inv. Nom. Current	16-75 Analog In X30/11	18-33 Analog Out X42/7 [V]	20-31 User Defined Refrigerant A1	21-0* Ext. CL Autotuning
16-37 Inv. Max. Current	16-76 Analog In X30/12	18-34 Analog Out X42/9 [V]	20-32 User-defined Refrigerant A2	21-00 Closed-loop Type

13.0.8 Main Menu Structure - page 6

16-38 SL Controller State	16-77 Analog Out X30/8 [mA]	18-35 Analog Out X42/11 [V]	20-33 User-defined Refrigerant A3	21-01 PID Performance
16-39 Control Card Temp.	16-8* Fieldbus & FC Port	18-36 Analog Input X48/2 [mA]	20-34 Duct 1 Area [m2]	21-02 PID Output Change
16-40 Logging Buffer Full	16-80 Fieldbus CTW 1	18-37 Temp. Input X48/4	20-35 Duct 1 Area [in2]	21-03 Minimum Feedback Level
16-43 Timed Actions Status	16-82 Fieldbus REF 1	18-38 Temp. Input X48/7	20-36 Duct 2 Area [m2]	21-04 Maximum Feedback Level
16-49 Current Fault Source	16-84 Comm. Option STW	18-39 Temp. Input X48/10	20-37 Duct 2 Area [in2]	21-09 PID Autotuning
16-5* Ref. & Feedb.	16-85 FC Port CTW 1	18-5* Ref. & Feedb.	20-38 Air Density Factor [%]	21-1* Ext. CL 1 Ref./Fb.
16-50 External Reference	16-86 FC Port REF 1	18-50 Sensorless Readout [unit]	20-6* Sensorless	21-10 Ext. 1 Ref./Feedback Unit
16-52 Feedback [Unit]	16-9* Diagnosis Readouts	20-** Drive Closed-loop	20-60 Sensorless Unit	21-11 Ext. 1 Minimum Reference
16-53 Digi Pot Reference	16-90 Alarm Word	20-0* Feedback	20-69 Sensorless Information	21-12 Ext. 1 Maximum Reference
16-54 Feedback 1 [Unit] 2	16-91 Alarm Word	20-00 Feedback 1 Source	20-7* PID Autotuning	21-13 Ext. 1 Reference Source
16-55 Feedback 2 [Unit]	16-92 Warning Word	20-01 Feedback 1 Conversion	20-70 Closed-loop Type	21-14 Ext. 1 Feedback Source
16-56 Feedback 3 [Unit]	16-93 Warning Word 2	20-02 Feedback 1 Source Unit	20-71 PID Performance	21-15 Ext. 1 Setpoint
16-58 PID Output [%]	16-94 Ext. Status Word	20-03 Feedback 2 Source	20-72 PID Output Change	21-17 Ext. 1 Reference [Unit]
16-6* Inputs & Outputs	16-96 Maintenance Word	20-04 Feedback 2 Conversion	20-73 Minimum Feedback Level	21-18 Ext. 1 Feedback [Unit]
16-60 Digital Input	18-** Info & Readouts	20-05 Feedback 2 Source Unit	20-74 Maximum Feedback Level	21-19 Ext. 1 Output [%]
16-61 Terminal 53 Switch Setting	18-0* Maintenance Log	20-06 Feedback 3 Source	20-79 PID Autotuning	21-2* Ext. CL 1 PID
16-62 Analog Input 53	18-00 Maintenance Log: Item	20-07 Feedback 3 Conversion	20-8* PID Basic Settings	21-20 Ext. 1 Normal/Inverse Control
16-63 Terminal 54 Switch Setting	18-01 Maintenance Log: Action	20-08 Feedback 3 Source Unit	20-81 PID Normal/ Inverse Control	21-21 Ext. 1 Proportional Gain
16-64 Analog Input 54	18-02 Maintenance Log: Time	20-12 Reference/Feedback Unit	20-82 PID Start Speed [RPM]	21-22 Ext. 1 Integral Time
16-65 Analog Output 42 [mA]	18-03 Maintenance Log: Date and Time	20-13 Minimum Reference/Feedb.	20-83 PID Start Speed [Hz]	21-23 Ext. 1 Differentiation Time
21-24 Ext. 1 Dif. Gain Limit	21-60 Ext. 3 Normal/Inverse Control	22-4* Sleep Mode	22-86 Speed at Design Point [Hz]	23-60 Trend Variable
21-3* Ext. CL 2 Ref./Fb.	21-61 Ext. 3 Proportional Gain	22-40 Minimum Run Time	22-87 Pressure at No-Flow Speed	23-61 Continuous Bin Data
21-30 Ext. 2 Ref./Feedback Unit	21-62 Ext. 3 Integral Time	22-41 Minimum Sleep Time	22-88 Pressure at Rated Speed	23-62 Timed Bin Data
21-31 Ext. 2 Minimum Reference	21-63 Ext. 3 Differentiation Time	22-42 Wake-up Speed [RPM]	22-89 Flow at Design Point	23-63 Timed Period Start

13.0.9 Main Menu Structure - page 7

21-32 Ext. 2 Maximum Reference	21-64 Ext. 3 Dif. Gain Limit	22-43 Wake-up Speed [Hz]	22-90 Flow at Rated Speed	23-64 Timed Period Stop
21-33 Ext. 2 Reference Source	22-** Appl. Functions	22-44 Wake-up Ref./FB Difference	23-** Time-based Functions	23-65 Minimum Bin Value
21-34 Ext. 2 Feedback Source	22-0* Miscellaneous	22-45 Setpoint Boost	23-0* Timed Actions	23-66 Reset Continuous Bin Data
21-35 Ext. 2 Setpoint	22-00 External Interlock Delay	22-46 Maximum Boost Time	23-00 ON Time	23-67 Reset Timed Bin Data
21-37 Ext. 2 Reference [Unit]	22-01 Power Filter Time	22-5* End of Curve	23-01 ON Action	23-8* Payback Counter
21-38 Ext. 2 Feedback [Unit]	22-2* No-Flow Detection	22-50 End of Curve Function	23-02 OFF Time	23-80 Power Reference Factor
21-39 Ext. 2 Output [%]	22-20 Low Power Auto Setup	22-51 End of Curve Delay	23-03 OFF Action	23-81 Energy Cost
21-4* Ext. CL 2 PID	22-21 Low Power Detection	22-6* Broken Belt Detection	23-04 Occurrence	23-82 Investment
21-40 Ext. 2 Normal/Inverse Control	22-22 Low Speed Detection	22-60 Broken Belt Function	23-08 Timed Actions Mode	23-83 Energy Savings
21-41 Ext. 2 Proportional Gain	22-23 No-Flow Function	22-61 Broken Belt Torque	23-09 Timed Actions Reactivation	23-84 Cost Savings
21-42 Ext. 2 Integral Time	22-24 No-Flow Delay	22-62 Broken Belt Delay	23-1* Maintenance	24-** Appl. Functions 2
21-43 Ext. 2 Differentiation Time	22-26 Dry Pump Function	22-7* Short Cycle Protection	23-10 Maintenance Item	24-0* Fire Mode
21-44 Ext. 2 Dif. Gain Limit	22-27 Dry Pump Delay	22-75 Short Cycle Protection	23-11 Maintenance Action	24-00 Fire Mode Function
21-5* Ext. CL 3 Ref./Fb.	22-3* No-Flow Power Tuning	22-76 Interval between Starts	23-12 Maintenance Time Base	24-01 Fire Mode Configuration
21-50 Ext. 3 Ref./Feedback Unit	22-30 No-Flow Power	22-77 Minimum Run Time	23-13 Maintenance Time Interval	24-02 Fire Mode Unit
21-51 Ext. 3 Minimum Reference	22-31 Power Correction Factor	22-78 Minimum Run Time Override	23-14 Maintenance Date and Time	24-03 Fire Mode Min Reference
21-52 Ext. 3 Maximum Reference	22-32 Low Speed [RPM]	22-79 Minimum Run Time Override Value	23-15 Reset Maintenance Word	24-04 Fire Mode Max Reference
21-53 Ext. 3 Reference Source	22-33 Low Speed [Hz]	22-8* Flow Compensation	23-16 Maintenance Text	24-05 Fire Mode Preset Reference
21-54 Ext. 3 Feedback Source	22-34 Low Speed Power [kW]	22-80 Flow Compensation	23-5* Energy Log	24-06 Fire Mode Reference Source
21-55 Ext. 3 Setpoint	22-35 Low Speed Power [HP]	22-81 Square-linear Curve Approximation	23-50 Energy Log Resolution	24-07 Fire Mode Feedback Source
21-57 Ext. 3 Reference [Unit]	22-36 High Speed [RPM]	22-82 Work Point Calculation	23-51 Period Start	24-09 Fire Mode Alarm Handling
21-58 Ext. 3 Feedback [Unit]	22-37 High Speed [Hz]	22-83 Speed at No-Flow [RPM]	23-53 Energy Log	24-1* Drive Bypass
21-59 Ext. 3 Output [%]	22-38 High Speed Power [kW]	22-84 Speed at No-Flow [Hz]	23-54 Reset Energy Log	24-10 Drive Bypass Function
21-6* Ext. CL 3 PID	22-39 High Speed Power [HP]	22-85 Speed at Design Point [RPM]	23-6* Trending	24-11 Drive Bypass Delay Time
24-9* Multi-Motor Funct.	25-25 OBW Time	25-59 Run-on Line Delay	26-2* Analog Input X42/3	26-53 Terminal X42/9 Bus Control

13.0.10 Main Menu Structure - page 8

24-90 Missing Motor Function	25-26 Destage At No-Flow	25-8* Status	26-20 Terminal X42/3 Low Voltage	26-54 Terminal X42/9 Timeout Preset
24-91 Missing Motor Coefficient 1	25-27 Stage Function	25-80 Cascade Status	26-21 Terminal X42/3 High Voltage	26-6* Analog Out X42/11
24-92 Missing Motor Coefficient 2	25-28 Stage Function Time	25-81 Pump Status	26-24 Term. X42/3 Low Ref./ Feedb. Value	26-60 Terminal X42/11 Output
24-93 Missing Motor Coefficient 3	25-29 Destage Function	25-82 Lead Pump	26-25 Term. X42/3 High Ref./ Feedb. Value	26-61 Terminal X42/11 Min. Scale
24-94 Missing Motor Coefficient 4	25-30 Destage Function Time	25-83 Relay Status	26-26 Term. X42/3 Filter Time Constant	26-62 Terminal X42/11 Max. Scale
24-95 Locked Rotor Function	25-4* Staging Settings	25-84 Pump ON Time	26-27 Term. X42/3 Live Zero	26-63 Terminal X42/11 Bus Control
24-96 Locked Rotor Coefficient 1	25-40 Ramp-down Delay	25-85 Relay ON Time	26-3* Analog Input X42/5	26-64 Terminal X42/11 Timeout Preset
24-97 Locked Rotor Coefficient 2	25-41 Ramp-up Delay	25-86 Reset Relay Counters	26-30 Terminal X42/5 Low Voltage	31-** Bypass Option
24-98 Locked Rotor Coefficient 3	25-42 Staging Threshold	25-9* Service	26-31 Terminal X42/5 High Voltage	31-00 Bypass Mode
24-99 Locked Rotor Coefficient 4	25-43 Destaging Threshold	25-90 Pump Interlock	26-34 Term. X42/5 Low Ref./ Feedb. Value	31-01 Bypass Start Time Delay
25-** Cascade Controller	25-44 Staging Speed [RPM]	25-91 Manual Alternation	26-35 Term. X42/5 High Ref./ Feedb. Value	31-02 Bypass Trip Time Delay
25-0* System Settings	25-45 Staging Speed [Hz]	26-** Analog I/O Option	26-36 Term. X42/5 Filter Time Constant	31-03 Test Mode Activation
25-00 Cascade Controller	25-46 De-staging Speed [RPM]	26-0* Analog I/O Mode	26-37 Term. X42/5 Live Zero	31-10 Bypass Status Word
25-02 Motor Start	25-47 Destaging Speed [Hz]	26-00 Terminal X42/1 Mode	24-4* Analog Out X42/7	31-11 Bypass Running Hours
25-04 Pump Cycling	25-5* Alternation Settings	26-01 Terminal X42/3 Mode	26-40 Terminal X42/7 Output	13-19 Remote Bypass Activation
25-05 Fixed Lead Pump	25-50 Lead Pump Alternation	26-02 Terminal X42/5 Mode	26-41 Terminal X42/7 Min. Scale	35-** Sensor Input Option
25-06 Number of Pumps	25-51 Alternation Event	26-1* Analog Input X42/1	26-42 Terminal X42/7 Max. Scale	35-0* Temp. Input Mode
25-2* Bandwidth Settings	25-52 Alternation Time Interval	26-10 Terminal X42/1 Low Voltage	26-43 Terminal X42/7 Bus Control	35-00 Term. X48/4 Temp. Unit
25-20 Staging Bandwidth	25-53 Alternation Timer Value	26-11 Terminal X42/1 High Voltage	26-44 Terminal X42/7 Timeout Preset	35-01 Term. X48/4 Input Type
25-21 Override Bandwidth	25-54 Alternation Predelineated Time	26-14 Term. X42/1 Low Ref./ Feedb. Value	26-5* Analog Out X42/9	35-02 Term. X48/7 Temp. Unit
25-22 Fixed Speed Bandwidth	25-55 Alternate if Load < 50%	26-15 Term. X42/1 High Ref./ Feedb. Value	26-50 Terminal X42/9 Output	35-03 Term. X48/7 Input Type
25-23 SBW Staging Delay	25-56 Staging Mode at Alternation	26-16 Term. X42/1 Filter Time Constant	26-51 Terminal X42/9 Min. Scale	35-04 Term. X48/10 Temp. Unit
25-24 SBW De-staging Delay	25-58 Run Next Pump Delay	26-17 Term. X42/1 Live Zero	26-52 Terminal X42/9 Max. Scale	35-05 Term. X48/10 Input Type

35-06 Temperature Sensor Alarm Function	35-17 Term. X48/4 High Temp. Limit	35-27 Term. X48/7 High Temp. Limit	35-37 Term. X48/10 High Temp. Limit	35-45 Term. X48/2 High Ref./ Feedb. Value
35-1* Temp. Input X48/4	35-2* Temp. Input X48/7	35-3* Temp. Input X48/10	35-4* Analog Input X48/2	35-46 Term. X48/2 Filter Time Constant
35-14 Term. X48/4 Filter Time Constant	35-24 Term. X48/7 Filter Time Constant	35-34 Term. X48/10 Filter Time Constant	35-42 Term. X48/2 Low Current	35-47 Term. X48/2 Live Zero
35-15 Term. X48/4 Temp. Monitor	35-25 Term. X48/7 Temp. Monitor	35-35 Term. X48/10 Temp. Monitor	35-43 Term. X48/2 High Current	
35-16 Term. X48/4 Low Temp. Limit	35-26 Term. X48/7 Low Temp. Limit	35-36 Term. X48/10 Low Temp. Limit	35-44 Term. X48/2 Low Ref./ Feedb. Value	

14 WARNINGS AND ALARMS

14.0.1 System Monitoring

The adjustable frequency drive monitors the condition of its input power, output, and motor factors as well as other system performance indicators. A warning or alarm may not necessarily indicate a problem internal to the adjustable frequency drive itself. In many cases it indicates failure conditions from input voltage, motor load or temperature, external signals, or other areas monitored by the adjustable frequency drive's internal logic. Be sure to investigate those areas exterior to the adjustable frequency drive as indicated in the alarm or warning.

14.0.2 Warning and Alarm Types

Warnings

A warning is issued when an alarm condition is impending or when an abnormal operating condition is present and may result in the adjustable frequency drive issuing an alarm. A warning clears by itself when the abnormal condition is removed.

Alarms

Trip

An alarm is issued when the adjustable frequency drive is tripped, that is, the adjustable frequency drive suspends operation to prevent adjustable frequency drive or system damage. The motor will coast to a stop. The adjustable frequency drive logic will continue to operate and monitor the adjustable frequency drive status. After the fault condition is remedied, the adjustable frequency drive can be reset. It will then be ready to start operation again.

A trip can be reset in any of 4 ways:

- Press [RESET] on the LCP
- Digital reset input command
- Serial communication reset input command
- Auto reset

Trip Lock

An alarm that causes the adjustable frequency drive to trip lock requires that input power is cycled. The motor will coast to a stop. The adjustable frequency drive logic will continue to operate and monitor the adjustable frequency drive status. Remove input power to the adjustable frequency drive and correct the cause of the fault, then restore power. This action puts the adjustable frequency drive into a trip condition as described above and may be reset in any of those four ways.

14.0.3 Warning and Alarm Displays

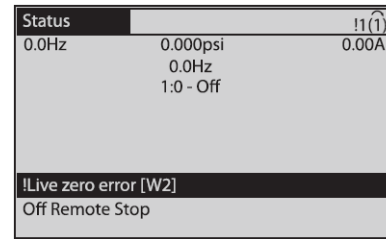

An alarm or trip lock alarm will flash on display along with the alarm number.

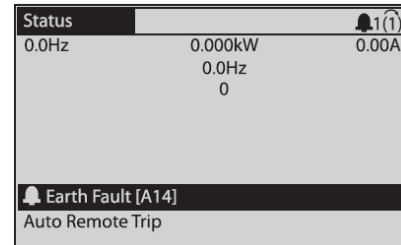

In addition to the text and alarm code on the adjustable frequency drive display, the status indicator lights operate.

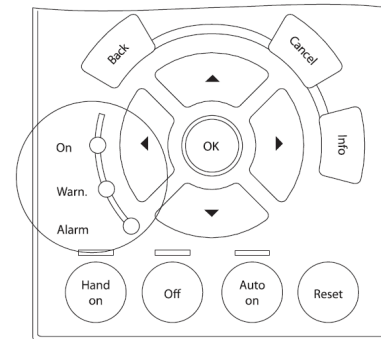

	Warn. LED	Alarm LED
Warning	ON	OFF
Alarm	OFF	ON (Flashing)
Trip Lock	ON	ON (Flashing)

14.0.4 Warning and Alarm Definitions

The table below defines whether a warning is issued prior to an alarm, and whether the alarm trips the unit or trip locks the unit.

Table 9: Alarm/Warning Code List

No.	Description	Warning	Alarm/Trip	Alarm/Trip Lock	Parameter Reference
1	10 Volts low	X			
2	Live zero error	(X)	(X)		6-01
4	Mains phase loss	(X)	(X)	(X)	14-12
5	DC link voltage high	X			
6	DC link voltage low	X			
7	DC overvoltage	X	X		
8	DC undervoltage	X	X		
9	Inverter overloaded	X	X		
10	Motor ETR overtemperature	(X)	(X)		1-90
11	Thrmstr overld	(X)	(X)		1-90
12	Torque limit	X	X		
13	Overcurrent	X	X	X	
14	Ground fault	X	X	X	
15	Hardware mismatch		X	X	
16	Short Circuit		X	X	
17	Control word timeout	(X)	(X)		8-04
23	Internal Fan Fault	X			
24	External Fan Fault	X			14-53
25	Brake resistor short-circuited	X			
26	Brake resistor power limit	(X)	(X)		2-13
27	Brake chopper short-circuited	X	X		
28	Brake check	(X)	(X)		2-15
29	Drive overtemperature	X	X	X	
30	Motor phase U missing	(X)	(X)	(X)	4-58
31	Motor phase V missing	(X)	(X)	(X)	4-58
32	Motor phase W missing	(X)	(X)	(X)	4-58
33	Inrush fault		X	X	
34	Fieldbus communication fault	X	X		
35	Out of frequency range	X	X		
36	Mains failure	X	X		
37	Phase Imbalance	X	X		
38	Internal fault		X	X	
39	Heatsink sensor		X	X	
40	Overload of Digital Output Terminal 27	(X)			5-00, 5-01
41	Overload of Digital Output Terminal 29	(X)			5-00, 5-02
42	Overload of Digital Output On X30/6	(X)	5-32		
42	Overload of Digital Output On X30/7	(X)	5-33		
46	Pwr. card supply		X	X	
47	24 V supply low	X	X	X	
48	1.8 V supply low		X	X	
49	Speed limit	X	(X)		1-86
50	AMA calibration failed		X		
51	AMA check Unom and Inom		X		
52	AMA low Inom		X		
53	AMA motor too big		X		

No.	Description	Warning Alarm/ Trip	Alarm/Trip Lock	Parameter Reference	
54	AMA motor too small		X		
55	AMA Parameter out of range		X		
56	AMA interrupted by user		X		
57	AMA timeout		X		
58	AMA internal fault	X	X		
59	Current limit	X			
60	External Interlock	X			
62	Output Frequency at Maximum Limit	X			
64	Voltage Limit	X			
65	Control Board Overtemperature	X	X	X	
66	Heatsink Temperature Low	X			
67	Option Configuration has Changed		X		
69	Pwr. Card Temp		X	X	
70	Illegal FC configuration			X	
71	PTC 1 Safe Stop	X	X ¹⁾		
72	Dangerous Failure			X ¹⁾	
73	Safe Stop Auto Restart				
76	Power Unit Set-up	X			
79	Illegal PS config		X	X	
80	Drive Initialized to Default Value		X		
91	Analog input 54 wrong settings			X	
92	No-Flow	X	X		22-2*
93	Dry Pump	X	X		22-2*
94	End of Curve	X	X		22-5*
95	Broken Belt	X	X		22-6*
96	Start Delayed	X			22-7*
97	Stop Delayed	X			22-7*
98	Clock Fault	X			0-7*
201	Fire M was Active				
202	Fire M Limits Exceeded				
203	Missing Motor				
204	Locked Rotor				
243	Brake IGBT	X	X		
244	Heatsink temp	X	X	X	
245	Heatsink sensor		X	X	
246	Pwr.card supply		X	X	
247	Pwr.card temp		X	X	
248	Illegal PS config		X	X	
250	New spare parts			X	
251	New Type Code		X	X	

(X) Dependent on parameter

¹⁾ Cannot be Auto reset via 14-20 Reset Mode

14.0.5 Fault Messages

The warning/alarm information below defines the warning/alarm condition, provides the probable cause for the condition, and details a remedy or troubleshooting procedure.

WARNING 1, 10 volts low

The control card voltage is below 10 V from terminal 50. Remove some of the load from terminal 50, as the 10 V supply is overloaded. Max. 15 mA or minimum 590 Ohms. This condition can be caused by a short in a connected potentiometer or improper wiring of the potentiometer.

Troubleshooting

Remove the wiring from terminal 50. If the warning clears, the problem is with the customer wiring. If the warning does not clear, replace the control card.

WARNING/ALARM 2, Live zero error

This warning or alarm will only appear if programmed by the user in 6-01 Live Zero Timeout Function. The signal on one of the analog inputs is less than 50% of the minimum value programmed for that input. This condition can be caused by broken wiring or faulty device sending the signal.

Troubleshooting

Check connections on all the analog input terminals. Control card terminals 53 and 54 for signals, terminal 55 common. MCB 101 terminals 11 and 12 for signals, terminal 10 common. MCB 109 terminals 1, 3, 5 for signals, terminals 2, 4, 6 common).

Check that the adjustable frequency drive programming and switch settings match the analog signal type.

Perform Input Terminal Signal Test.

WARNING/ALARM 4, Mains phase loss

A phase is missing on the supply side, or the line voltage imbalance is too high. This message also appears for a fault in the input rectifier on the adjustable frequency drive. Options are programmed at 14-12 Function at Mains Imbalance.

Troubleshooting

Check the supply voltage and supply currents to the adjustable frequency drive.

WARNING 5, DC link voltage high

The intermediate circuit voltage (DC) is higher than the high voltage warning limit. The limit is dependent on the adjustable frequency drive voltage rating. The adjustable frequency drive is still active.

WARNING 6, DC link voltage low

The intermediate circuit voltage (DC) is lower than the low voltage warning limit. The limit is dependent on the adjustable frequency drive voltage rating. The adjustable frequency drive is still active.

WARNING/ALARM 7, DC overvoltage

If the intermediate circuit voltage exceeds the limit, the adjustable frequency drive trips after a time.

Troubleshooting

Connect a brake resistor

Extend the ramp time

Change the ramp type

Activate functions in 2-10 Brake Function

Increase 14-26 Trip Delay at Inverter Fault

WARNING/ALARM 8, DC undervoltage

If the intermediate circuit voltage (DC) drops below the undervoltage limit, the adjustable frequency drive checks if a 24 VDC backup supply is connected. If no 24 VDC backup supply is connected, the adjustable frequency drive trips after a fixed time delay. The time delay varies with unit size.

Troubleshooting

Check that the supply voltage matches the adjustable frequency drive voltage.

Perform Input voltage test

Perform soft charge and rectifier circuit test

WARNING/ALARM 9, Inverter overload

The adjustable frequency drive is about to cut out because of an overload (current too high for too long). The counter for electronic, thermal inverter protection gives a warning at 98% and trips at 100%, while giving an alarm. The adjustable frequency drive cannot be reset until the counter is below 90%.

The fault is that the adjustable frequency drive has been overloaded by more than 100% for too long.

Troubleshooting

Compare the output current shown on the LCP with the adjustable frequency drive rated current.

Compare the output current shown on the LCP with measured motor current.

Display the Thermal Drive Load on the LCP and monitor the value. When running above the adjustable frequency drive continuous current rating, the counter should increase. When running below the adjustable frequency drive continuous current rating, the counter should decrease.

See the derating section in the *Design Guide* for more details if a high switching frequency is required.

WARNING/ALARM 10, Motor Overload Temperature

According to the electronic thermal protection (ETR), the motor is too hot. Select whether the adjustable frequency drive gives a warning or an alarm when the counter reaches 100% in 1-90 Motor Thermal Protection. The fault occurs when the motor is overloaded by more than 100% for too long.

Troubleshooting

- Check for motor overheating.
- Check if the motor is mechanically overloaded.
- Check that the motor current set in *1-24 Motor Current* is correct.
- Ensure that Motor data in parameters 1-20 through 1-25 are set correctly.
- If an external fan is in use, check in *1-91 Motor External Fan* that it is selected.
- Running AMA in *1-29 Automatic Motor Adaptation (AMA)* may tune the adjustable frequency drive to the motor more accurately and reduce thermal loading.

WARNING/ALARM 11, Thermistor overload

The thermistor might be disconnected. Select whether the adjustable frequency drive gives a warning or an alarm in *1-90 Motor Thermal Protection*.

Troubleshooting

- Check for motor overheating.
- Check if the motor is mechanically overloaded.
- When using terminal 53 or 54, check that the thermistor is connected correctly between either terminal 53 or 54 (analog voltage input) and terminal 50 (+10 V supply) and that the terminal switch for 53 or 54 is set for voltage. Check *1-93 Thermistor Source* selects terminal 53 or 54.
- When using digital inputs 18 or 19, check that the thermistor is connected correctly between either terminal 18 or 19 (digital input PNP only) and terminal 50. Check *1-93 Thermistor Source* selects terminal 18 or 19.

WARNING/ALARM 12, Torque limit

The torque has exceeded the value in 4-16 Torque Limit Motor Mode or the value in 4-17 Torque Limit Generator Mode. 14-25 Trip Delay at Torque Limit can change this from a warning only condition to a warning followed by an alarm.

Troubleshooting

- If the motor torque limit is exceeded during ramp-up, extend the ramp-up time.
- If the generator torque limit is exceeded during ramp-down, extend the ramp-down time.
- If torque limit occurs while running, possibly increase the torque limit. Be sure the system can operate safely at a higher torque.
- Check the application for excessive current draw on the motor.

WARNING/ALARM 13, Overcurrent

The inverter peak current limit (approx. 200% of the rated current) is exceeded. The warning lasts about 1.5 sec. Then the adjustable frequency drive trips and issues an alarm. This fault may be caused by shock loading or fast acceleration with high inertia loads. If extended mechanical brake control is selected, trip can be reset externally.

Troubleshooting

- Remove power and check if the motor shaft can be turned.
- Make sure that the motor size matches the adjustable frequency drive.
- Check parameters 1-20 through 1-25 for correct motor data.

WARNING/ALARM 14, Ground Fault

There is current from the output phases to ground, either in the cable between the adjustable frequency drive and the motor or in the motor itself.

Troubleshooting

- Remove power to the adjustable frequency drive and repair the ground fault.
- Check for ground faults in the motor by measuring the resistance to ground of the motor leads and the motor with a megohmmeter.

WARNING/ALARM 15, Hardware Mismatch

A fitted option is not operational with the present control board hardware or software.

Record the value of the following parameters and contact your Danfoss supplier:

15-40 FC Type

15-41 Power Section

- 15-42 Voltage
- 15-43 Software Version
- 15-45 Actual Typecode String
- 15-49 SW ID Control Card
- 15-50 SW ID Power Card
- 15-60 Option Mounted
- 15-61 Option SW Version

WARNING/ALARM 16, Short Circuit

There is a short circuit in the motor or motor wiring. Remove power to the adjustable frequency drive and repair the short circuit.

WARNING/ALARM 17, Control Word Timeout

There is no communication to the adjustable frequency drive.

The warning will only be active when 8-04 Control Time-out Function is NOT set to [0] OFF.

If 8-04 Control Timeout Function is set to Stop and Trip, a warning appears and the adjustable frequency drive ramps down until it stops then displays an alarm.

Troubleshooting

- Check connections on the serial communication cable.
- Increase *8-03 Control Timeout Time*.
- Check the operation of the communication equipment.
- Verify proper installation based on EMC requirements.

WARNING/ALARM 23, Internal Fan Fault

The fan warning function checks if the fan is running. The fan warning can be disabled in *14-53 Fan Monitor*.

Troubleshooting

- Check for proper fan operation.
- Cycle power to the adjustable frequency drive and check that the fan operates briefly at startup.
- Check the sensors on the heatsink and control card.

WARNING/ALARM 24, External Fan Fault

The fan warning function checks if the fan is running. The fan warning can be disabled in *14-53 Fan Monitor*.

Troubleshooting

- Check for proper fan operation.
- Cycle power to the adjustable frequency drive and check that the fan operates briefly at startup.
- Check the sensors on the heatsink and control card.

WARNING/ALARM 25, Brake Resistor Short Circuit

The brake resistor is monitored during operation. If a short circuit occurs, the brake function is disabled and the warning appears. The adjustable frequency drive is still operational but without the brake function. Remove power to the adjustable frequency drive and replace the brake resistor (see *2-15 Brake Check*).

WARNING/ALARM 26, Brake Resistor Power Limit

The power transmitted to the brake resistor is calculated as a mean value over the last 120 seconds of run time. The calculation is based on the intermediate circuit voltage and the brake resistance value set in *2-16 AC Brake Max. Current*. The warning is active when the dissipated braking is higher than 90% of the brake resistance power. If *Trip [2]* is selected in *2-13 Brake Power Monitoring*, the adjustable frequency drive will trip when the dissipated braking energy reaches 100%.

WARNING/ALARM 27, Brake Chopper Fault

The brake transistor is monitored during operation and if a short circuit occurs, the brake function is disabled and a warning is issued. The adjustable frequency drive is still operational but, since the brake transistor has short-circuited, substantial power is transmitted to the brake resistor, even if it is inactive.

Remove power to the adjustable frequency drive and remove the brake resistor.

WARNING/ALARM 28, Brake Check Failed

The brake resistor is not connected or not working. Check *2-15 Brake Check*.

WARNING/ALARM 29, Heatsink Temp

The maximum temperature of the heatsink has been exceeded. The temperature fault will not reset until the temperature falls below the reset heatsink temperature. The trip and reset points are based on the adjustable frequency drive power size.

Troubleshooting

Check for the following conditions.

- Ambient temperature too high.
- Motor cable too long.
- Incorrect airflow clearance above and below the adjustable frequency drive.
- Blocked airflow around the adjustable frequency drive.
- Damaged heatsink fan.
- Dirty heatsink.

WARNING/ALARM 30, Motor phase U missing

Motor phase U between the adjustable frequency drive and the motor is missing.

Remove power from the adjustable frequency drive and check motor phase U.

WARNING/ALARM 31, Motor phase V missing

Motor phase V between the adjustable frequency drive and the motor is missing.

Remove power from the adjustable frequency drive and check motor phase V.

WARNING/ALARM 30, Motor phase W missing

Motor phase W between the adjustable frequency drive and the motor is missing.

Remove power from the adjustable frequency drive and check motor phase W.

WARNING/ALARM 33, Inrush Fault

Too many power-ups have occurred within a short time period. Let the unit cool to operating temperature.

WARNING/ALARM 34, Fieldbus Communication Fault

Communication between the serial communication bus and the communication option card is not operating.

WARNING/ALARM 36, Mains Failure

This warning/alarm is only active if the supply voltage to the adjustable frequency drive is lost and *14-10 Mains Failure* is NOT set to [0] *No Function*. Check the fuses to the adjustable frequency drive and line power supply to the unit.

WARNING/ALARM 36, Internal Fault

When an internal fault occurs, a code number defined in the table below is displayed.

Troubleshooting

- Cycle power to the adjustable frequency drive.
- Check that the option is properly installed.
- Check for loose or missing wiring.

It may be necessary to contact your Danfoss supplier or service department. Note the code number for further troubleshooting directions.

No.	Text
0	Serial port cannot be initialized. Contact your Danfoss supplier or DanfossService Department.
256-258	Power EEPROM data is defect or too old.
512-519	Internal fault. Contact yourDanfoss supplier or DanfossService Department.
783	Parameter value outside of min/max limits

No.	Text
1024-1284	Internal fault. Contact your Danfoss supplier or the Danfoss Service Department.
1299	Option SW in slot A is too old.
1300	Option SW in slot B is too old.
1302	Option SW in slot C1 is too old.
1315	Option SW in slot A is not supported (not allowed).
1316	Option SW in slot B is not supported (not allowed).
1318	Option SW in slot C1 is not supported (not allowed).
1379-2819	Internal fault. Contact yourDanfoss supplier or DanfossService Department.
2820	LCP stack overflow.
2821	Serial port overflow.
2822	USB port overflow.
3072-5122	Parameter value is outside its limit.
5123	Option in slot A: Hardware incompatible with control board hardware.
5124	Option in slot B: Hardware incompatible with control board hardware.
5125	Option in slot C0: Hardware incompatible with control board hardware.
5126	Option in slot C1: Hardware incompatible with control board hardware.
5376-6231	Internal fault. Contact your Danfoss supplier or DanfossService Department.

WARNING/ALARM 39, Heatsink Sensor

No feedback from the heatsink temperature sensor.

The signal from the IGBT thermal sensor is not available on the power card. The problem could be on the power card, on the gate drive card, or the ribbon cable between the power card and gate drive card.

WARNING/ALARM 40, Overload of digital output terminal 27

Check the load connected to terminal 27 or remove shortcircuit connection. Check *5-00 Digital I/O Mode* and *5-01 Terminal 27 Mode*.

WARNING/ALARM 40, Overload of digital output terminal 29

Check the load connected to terminal 27 or remove shortcircuit connection. Check *5-00 Digital I/O Mode* and *5-01 Terminal 29 Mode*.

WARNING/ALARM 40, Overload of digital output on X30/6 or overload of digital output on x30/7

For X30/6, check the load connected to X30/6 or remove short-circuit connection. Check *5-32 Term X30/6 Digi Out (MCB 101)*.

For X30/7, check the load connected to X30/7 or remove short-circuit connection. Check *5-33 Term X30/7 Digi Out (MCB 101)*.

WARNING/ALARM 45, Ground Fault 2

Ground fault on start-up.

Troubleshooting

- Check for proper grounding and loose connections.
- Check for proper wire size.
- Check motor cables for short-circuits or leakage currents.

WARNING/ALARM 46, Power Card Supply

The supply on the power card is out of range.

There are three power supplies generated by the switch mode power supply (SMPS) on the power card: 24 V, 5 V, +/- 18 V. When powered with 24 VDC with the MCB 107 option, only the 24 V and 5 V supplies are monitored. When powered with three phase AC line voltage, all three supplied are monitored.

Troubleshooting

- Check for a defective power card.
- Check for a defective control card.
- Check for a defective option card.
- If a 24 VDC power supply is used, verify proper supply power.

WARNING/ALARM 47, 24 V Supply Low

The 24 V DC is measured on the control card. The external 24 VDC backup power supply may be overloaded; otherwise, contact your Danfoss supplier.

WARNING/ALARM 48, 1.8 Supply Low

The 1.8V DC supply used on the control card is outside of allowable limits. The power supply is measured on the control card. Check for a defective control card. If an option card is present, check for an overvoltage condition.

WARNING/ALARM 49, Speed Limit

When the speed is not within the specified range in *4-11 Motor Speed Low Limit [RPM]* and *4-13 Motor Speed High Limit [RPM]*, the adjustable frequency drive will show a warning. When the speed is below the specified limit in *1-86 Trip Speed Low [RPM]* (except when starting or stopping), the adjustable frequency drive will trip.

ALARM 50, AMA calibration failed

Contact your Danfoss supplier or Danfoss Service Department.

ALARM 51, AMA check U_{nom} and I_{nom}

The settings for motor voltage, motor current, and motor power are wrong. Check the settings in parameters 1-20 to 1-25.

ALARM 52, AMA low I_{nom}

The motor current is too low. Check the setting in *4-18 Current Limit*.

ALARM 53, AMA motor too big

The motor is too big for the AMA to operate.

ALARM 54, AMA motor too small

The motor is too small for the AMA to operate.

ALARM 55, AMA parameter out of range

The parameter values of the motor are outside of the acceptable range. AMA will not run.

ALARM 56, AMA interrupted by user

The AMA has been interrupted by the user.

ALARM 57, AMA timeout

Try to restart AMA again. Repeated restarts may overheat the motor.

ALARM 58, AMA internal fault

Contact your Danfoss supplier.

WARNING 59, Current limit

The current is higher than the value in *4-18 Current Limit*. Ensure that Motor data in parameters 1-20 through 1-25 are set correctly. Possibly increase the current limit. Be sure the system can operate safely at a higher limit.

ALARM 60, External interlock

A digital input signal is indicating a fault condition external to the adjustable frequency drive. An external interlock has commanded the adjustable frequency drive to trip. Clear the external fault condition. To resume normal operation, apply 24 VDC to the terminal programmed for external interlock. Reset the adjustable frequency drive.

WARNING 62, Output frequency at maximum limit

The output frequency has reached the value set in *4-19 Max Output Frequency*. Check the application to determine the cause. Possibly increase the output frequency limit. Be sure the system can operate safely at a higher output frequency. The warning will clear when the output drops below the maximum limit.

WARNING/ALARM 65, Control card over temperature

The cutout temperature of the control card is 176°F [80 °C].

Troubleshooting

- Check that the ambient operating temperature is within limits.
- Check for clogged filters.
- Check fan operation.
- Check the control card.

WARNING 66, Heatsink temperature low

The adjustable frequency drive is too cold to operate. This warning is based on the temperature sensor in the IGBT module. Increase the ambient temperature of the unit. Also, a trickle amount of current can be supplied to the adjustable frequency drive whenever the motor is stopped by setting *2-00 DC Hold/Preheat Current* at 5% and *1-80 Function* at Stop.

ALARM 67, Option module configuration has changed

One or more options have either been added or removed since the last power-down. Check that the configuration change is intentional and reset the adjustable frequency drive.

ALARM 68, Safe stop activated

Loss of the 24 VDC signal on terminal 37 has caused the adjustable frequency drive to trip. To resume normal operation, apply 24 VDC to terminal 37 and reset the adjustable frequency drive.

ALARM 69, Power card temperature

The temperature sensor on the power card is either too hot or too cold.

ALARM 70, Illegal FC configuration

The control card and power card are incompatible. Contact your supplier with the typecode of the unit from the nameplate and the part numbers of the cards to check compatibility.

ALARM 80, Drive initialized to default value

Parameter settings are initialized to default settings after a manual reset. Reset the unit to clear the alarm.

ALARM 92, No-flow

A no-flow condition has been detected in the system. *22-23 No-Flow Function* is set for alarm. Troubleshoot the system and reset the adjustable frequency drive after the fault has been cleared.

ALARM 93, Dry pump

A no-flow condition in the system with the frequency converter operating at high speed may indicate a dry pump. *22-26 Dry Pump Function* is set for alarm. Troubleshoot the system and reset the frequency converter after the fault has been cleared.

ALARM 94, End of curve

Feedback is lower than the setpoint. This may indicate leakage in the system. *22-50 End of Curve Function* is set for alarm. Troubleshoot the system and reset the adjustable frequency drive after the fault has been cleared.

ALARM 95, Broken belt

Torque is below the torque level set for no load, indicating a broken belt. *22-60 Broken Belt Function* is set for alarm. Troubleshoot the system and reset the adjustable frequency drive after the fault has been cleared.

ALARM 96, Start delayed

Motor start has been delayed due to short-cycle protection. *22-76 Interval between Starts* is enabled. Troubleshoot the system and reset the adjustable frequency drive after the fault has been cleared.

WARNING 97, Stop delayed

Stopping the motor has been delayed due to short cycle protection. *22-76 Interval between Starts* is enabled. Troubleshoot the system and reset the adjustable frequency drive after the fault has been cleared.

WARNING 98, Clock fault

Time is not set or the RTC clock has failed. Reset the clock in *0-70 Date and Time*.

WARNING 200, Fire mode

This indicates the adjustable frequency drive is operating in fire mode. The warning clears when fire mode is removed. See the fire mode data in the alarm log.

WARNING 201, Fire mode was active

This indicates the adjustable frequency drive had entered fire mode. Cycle power to the unit to remove the warning. See the fire mode data in the alarm log.

WARNING 202, Fire mode limits exceeded

While operating in fire mode one or more alarm conditions has been ignored which would normally trip the unit. Operating in this condition voids unit warranty. Cycle power to the unit to remove the warning. See the fire mode data in the alarm log.

WARNING 203, Missing motor

With an adjustable frequency drive operating multi-motors, an underload condition was detected. This could indicate a missing motor. Inspect the system for proper operation.

WARNING 204, Locked rotor

With an adjustable frequency drive operating multi-motors, an overload condition was detected. This could indicate a locked rotor. Inspect the motor for proper operation.

WARNING 250, New spare part

A component in the adjustable frequency drive has been replaced. Reset the adjustable frequency drive for normal operation.

WARNING 251, New type code

A component in the adjustable frequency drive has been replaced and the type code changed. Reset the adjustable frequency drive for normal operation.

14.1 Supplemental Warning and Alarm Settings

14.1.1 No-Flow

Definition: No-flow = low power consumption & low speed condition.

Pump response options:

- off [0]
- sleep mode [1]
- warning + run [2] (Factory default mode for SelfSensing pump)
- alarm + trip [3]

No-Flow Settings

1. Press [Main Menu].



2. Scroll down  to parameter 22-** *Appl. Functions*.

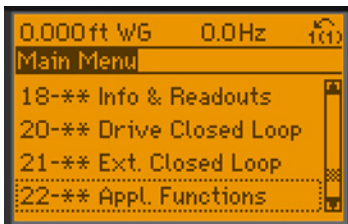

3. Press [OK].



4. Scroll Down  to parameter 22-2* *No-Flow Detection*.

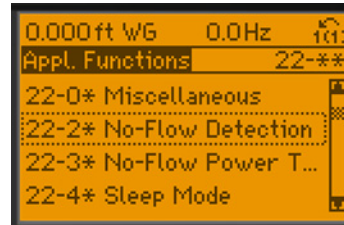

5. Press [OK].



6. Scroll down  to parameter 22-23 *No-Flow Function*.

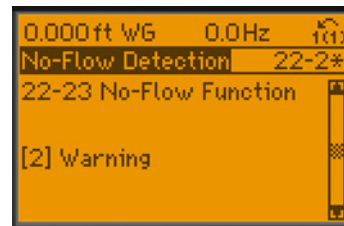

7. Press [OK].



8. Change parameter 22-23 to desired feature.

9. Press [Back].



10. Scroll down  to parameter 22-24 *No-Flow Delay*.

11. Select the amount of time the pump will run after no-flow is detected, before going into the mode selected in Parameter **22-23**.

14.1.2 Dry-Run

Definition: Dry-run = low power consumption and 60Hz high speed condition.

Pump response options:

- off [0],
- warning + run [1] (Factory default mode for SelfSensing pump)
- alarm + trip [2]

- manual reset alarm [3]

Dry-Run Settings

1. Press [Main Menu].



2. Scroll down to parameter 22-** Appl. Functions.



3. Press [OK].



4. Scroll Down to parameter 22-2* No-Flow Detection.

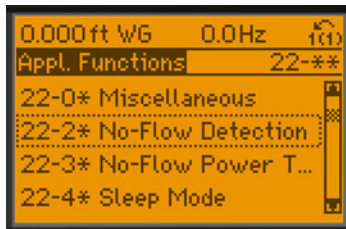

5. Press [OK].



6. Scroll down to parameter 22-26 Dry Pump Function.

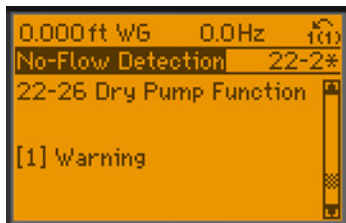

Press [OK].



7. Change parameter 22-26 to desired feature.

8. Press [Back].



9. Scroll down to parameter 22-27 Dry Pump Delay.

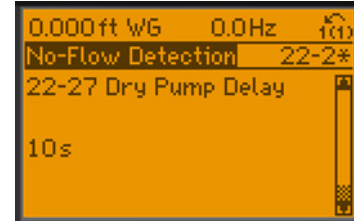

10. Select the amount of time the pump will run after dry-run is detected, before going into the mode selected in Parameter 22-26.

14.1.3 End-Of-Curve

Definition: End-of-curve = pump yielding too large a volume to ensure the set pressure @ 60Hz max speed condition).

Pump response options:

- off [0],
- warning + run [1] (Factory default mode for SelfSensing pump)
- alarm + trip [2]
- manual reset alarm [3]

End-Of-Curve Settings

1. Press [Main Menu].



2. Scroll down to parameter 22-** Appl. Functions.

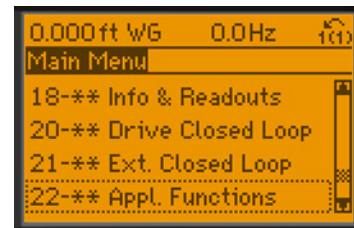

3. Press [OK].



4. Scroll Down  to parameter 22-5* End of Curve.

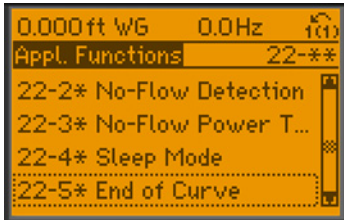

5. Press [OK].



6. Press [OK]  to change parameter 25-50 End of Curve Function.

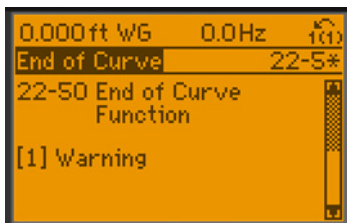

7. Change parameter 22-50 to desired feature.

8. Press [Back].



9. Scroll down  to parameter 25-51 End of Curve Delay.

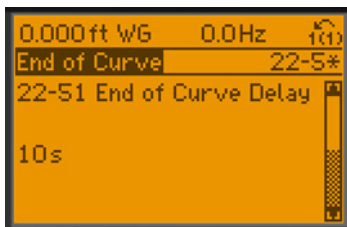

10. Select the amount of time the pump will run after end-of-curve is detected, before going into the mode selected in Parameter 25-50.

14.1.4 Function at Inverter Overload

Definition: Function at Inverter overload = running along HP limit curve.

Pump response options:

- default VFD trips at 110% rated current [0];
- de-rate VFD when load exceeds rating via speed reduction [1]. (Factory default mode for SelfSensing pump)

Function at Inverter Overload Settings

1. Press [Main Menu].



2. Scroll Down  to parameter 14-** Special Functions.

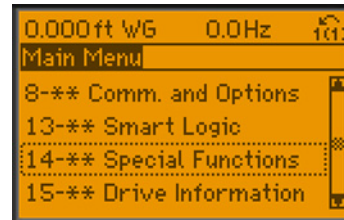

3. Press [OK].



4. Scroll Down  to parameter 14-6* Auto Derate.

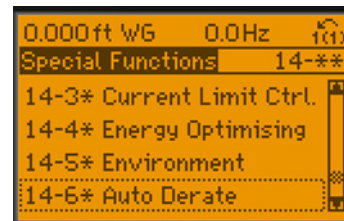

5. Scroll down  to parameter 14-61 Function at Inverter Overload.

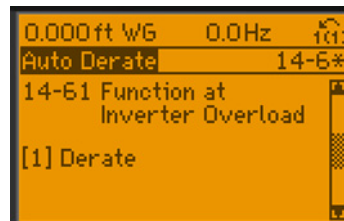

6. Press [OK].



7. Change parameter 14-61 to desired feature.

15 CASING/IMPELLER WEAR RING CLEARANCES

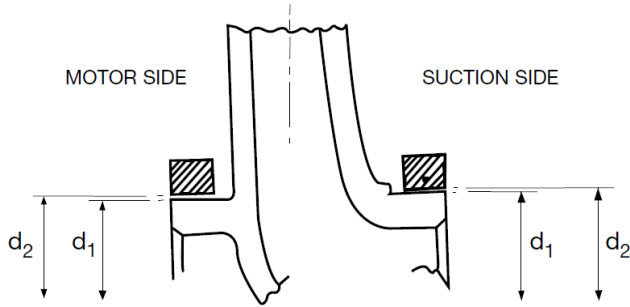

PUMP SIZE	WEAR RING-SUCTION SIDE				CLEARANCE	
	DIA d1		DIA d2			
	MAX	MIN	MAX	MIN	MAX	MIN
1506	2.363	2.361	2.377	2.375	.016	.012
1507	2.738	2.736	2.752	2.750	.016	.012
2006	2.863	2.861	2.877	2.875	.016	.012
2007	2.938	2.936	2.952	2.950	.016	.012
2009	3.363	3.361	3.377	3.375	.016	.012
2011	3.488	3.486	3.502	3.500	.016	.012
3006	3.238	3.236	3.252	3.250	.016	.012
3007	3.688	3.686	3.702	3.700	.016	.012
3009	3.613	3.611	3.627	3.625	.016	.012
3011	3.988	3.986	4.002	4.000	.016	.012
3013	3.738	3.736	3.752	3.750	.016	.012
4007	4.238	4.236	4.252	4.250	.016	.012
4009	4.611	4.609	4.627	4.625	.018	.014
4011	4.738	4.736	4.752	4.750	.016	.012
4013	4.613	4.611	4.627	4.625	.016	.012
5007	4.988	4.986	5.002	5.000	.016	.012
6009	5.861	5.859	5.877	5.875	.018	.014
6011	5.861	5.859	5.877	5.875	.018	.014
6013	5.861	5.859	5.877	5.875	.018	.014
8011	7.234	7.232	7.252	7.250	.020	.016
8013	7.734	7.732	7.752	7.750	.020	.016

16 SKS PUMP PROBLEM ANALYSIS

16.0.1 No Discharge

1. Pump not primed.
2. Speed too low.
3. System head too high.
4. Suction lift higher than pump is designed.
5. Impeller completely clogged.
6. Incorrect direction of rotation.
7. Air leak in suction line.

16.0.2 Insufficient Discharge Flow

1. Air leak in suction line.
2. Speed too low.
3. System head higher than anticipated.
4. Insufficient NPSH. Suction lift too high. Check gauges. Also check for clogged suction line or screen.
5. Impeller partially plugged.
6. Mechanical defects.
 - a. Worn wear rings
 - b. Impeller damaged.
 - c. Incorrect direction of rotation.

16.0.3 Insufficient Discharge Pressure

1. Speed too low.
2. System head less than anticipated.
3. Air in system.
4. Mechanical defects.
 - a. Worn wear rings.
 - b. Impeller damaged.
 - c. Impeller diameter too small.
 - d. Incorrect direction of rotation.

16.0.4 Loss of Suction

1. Leak in suction line.
2. Suction lift too high.
3. Insufficient NPSH.
4. Air in system.
5. Casing gasket defective.

16.0.5 Excessive Power Consumption

1. Speed too high.
2. System head lower than rating.
3. Specific gravity of liquid too high.
4. Mechanical defects.
 - a. Shaft bent.
 - b. Rotating elements bind.

- c. Worn wear ring.

16.0.6 Vibration

1. Air leak in suction line.
2. Air in system.
3. Impeller partially plugged.
4. Foundation not rigid.
5. Mechanical defects.
 - a. Damaged impeller.
 - b. Motor bearings worn.
 - c. Rotor out of balance.
 - d. Shaft bent.

16.0.7 Motor Runs Hot

1. Speed too high.
2. Specific gravity of liquid too high.
3. Mechanical defects.
 - a. Shaft bent.
 - b. Rotating elements bind.
 - c. Defective motor.
 - d. Voltage lower than rating.

17 SPECIFICATIONS

17.1 Power-dependent Specifications

Table 10: Line Power Supply 200-240 V AC

Line Power Supply 200-240 V AC - Normal overload 110% for 1 minute					
Adjustable frequency drive Typical Shaft Output [kW]	P1K1 1.1	P1K5 1.5	P2K2 2.2	P3K0 3	P3K7 3.7
IP20, IP21 max. cable cross-section (line power, motor, brake and load sharing) [mm ² (AWG)]	4, 4, 4 (12, 12, 12) (min. 0.2 (24))				
IP55, IP66 max. cable cross-section (line power, motor, brake and load sharing) [mm ² (AWG)]	4, 4, 4 (12, 12, 12)				
Max. cable cross-section with disconnect	6, 4, 4, (10, 12, 12)				

Table 11: Line Power Supply 3 x 200-240 V AC

Line Power Supply 3 x 200-240 V AC - Normal overload 110% for 1 minute					
Adjustable frequency drive Typical Shaft Output [kW]	P5K5 5.5	P7K5 7.5	P11K 11	P15K 15	P18K 18.5
IP20, IP21 max. cable cross-section (line power, motor, brake and load sharing) [mm ² (AWG)]	10, 10 (8,8-)		35,-,- (2,-,-)	35 (2)	50 (1)
IP21, IP55, IP66 max. cable cross-section (line power, motor) [mm ² (AWG)]	10, 10 (8,8-)		35, 25, 25 (2, 4, 4)	50 (1)	
IP21, IP55, IP66 max. cable cross-section (brake, load sharing) [mm ² (AWG)]	16, 10, 16 (6, 8, 6)		35,-,- (2,-,-)	50 (1)	

Table 12: Line Power Supply 3 x 200-240 V AC

Line Power Supply 3 x 200-240 V AC - Normal overload 110% for 1 minute				
Adjustable frequency drive Typical Shaft Output [kW]	P22K 22	P30K 30	P37K 37	P45K 45
IP20, IP21 max. cable cross-section (line power, motor, brake and load sharing) [mm ² (AWG)]	150 (300 MCM)			
IP21, IP55, IP66 max. cable cross-section (line power, motor) [mm ² (AWG)]	150 (300 MCM)			
IP21, IP55, IP66 max. cable cross-section (brake, load sharing) [mm ² (AWG)]	95 (3/0)			

Table 13: Line Power Supply 3 x 380-480 V AC

Line Power Supply 3 x 380-480 V AC - Normal overload 110% for 1 minute							
Adjustable frequency drive Typical Shaft Output [kW]	P1K1 1.1	P1K5 1.5	P2K2 2.2	P3K0 3	P4K0 4	P5K5 5.5	P7K5 7.5
Typical Shaft Output [HP] at 460 V	1.5	2.0	2.9	4.0	5.0	7.5	10
IP20, IP21 max. cable cross-section (line power, motor, brake and load sharing) [mm ² (AWG)] ¹⁾	4, 4, 4 (12, 12, 12) (min. 0.2 (24))						
IP55, IP66 max. cable cross-section (line power, motor, brake and load sharing) [mm ² (AWG)] ¹⁾	4, 4, 4 (12, 12, 12)						
Max. cable cross-section with disconnect	6, 4, 4 (10, 12, 12)						

Table 14: Line Power Supply 3 x 380-480 V AC

Line Power Supply 3 x 380-480 V AC - Normal overload 110% for 1 minute					
Adjustable frequency drive Typical Shaft Output [kW]	P11K 11	P15K 15	P18K 18.5	P22K 22	P30K 30
Typical Shaft Output [HP] at 460 V 15 20 25 30 40	15	20	25	30	40
IP20 max. cable cross-section (line power, brake, motor and load sharing)	16, 10, - (8, 8, -)		35,-,- (2,-,-)		35 (2)
IP21, IP55, IP66 max. cable cross-section (line power, motor) [mm ² (AWG)]	10, 10, 16 (6, 8, 6)		35, 25, 25 (2, 4, 4)		50 (1)
IP21, IP55, IP66 max. cable cross-section (brake, load sharing) [mm ² (AWG)]	10, 10, - (8, 8, -)		35, -, - (2, -, -)		50 (1)

Table 15: Line Power Supply 3 x 380-480 V AC

Line Power Supply 3 x 380-480 V AC - Normal overload 110% for 1 minute					
Adjustable frequency drive Typical Shaft Output [kW]	P37K 37	P45K 45	P55K 55	P75K 75	P90K 90
Typical Shaft Output [HP] at 460 V 15 20 25 30 40	50	60	75	100	125
IP20 max. cable cross-section (line power, brake, motor and load sharing)	50 (1)		150 (300 MCM)		
IP21, IP55, IP66 max. cable cross-section (line power, motor) [mm ² (AWG)]			150 (300 MCM)		
IP21, IP55, IP66 max. cable cross-section (brake, load sharing) [mm ² (AWG)]			95 (3/0)		

Table 16: With brake and load sharing 95 / 4/0

Line Power Supply 3 x 525-600 V AC - Normal overload 110% for 1 minute									
Size:	P1K1	P1K5	P2K2	P3K0	P3K7	PK40	P5K5	P7K5	P11K
Typical Shaft Output [kW]	1.1	1.5	2.2	3	3.7	4	5.5	7.5	11
IP20 max. cable cross-section (line power, motor, brake and load sharing) [mm ²]/[AWG]	4, 4, 4 (12, 12, 12) (min. 0.2 (24))								
IP55, IP66 max. cable cross-section (line power, motor, brake and load sharing) [mm ²]/[AWG]	4, 4, 4 (12, 12, 12) (min. 0.2 (24))								
Max. cable cross-section with disconnect	6, 4, 4 (12, 12, 12)								

Table 17: With brake and load sharing 95 / 4/0

Line Power Supply 3 x 525-600 V AC - Normal overload 110% for 1 minute									
Size:	P15K	P18K	P22K	P30K	P37K	P45K	P55K	P75K	P90K
Typical Shaft Output [kW]	15	18.5	22	30	37	45	55	75	90
IP20 max. cable cross-section (line power, motor, brake and load sharing) [mm ²]/[AWG]									
IP55, IP66 max. cable cross-section (line power, motor, brake and load sharing) [mm ²]/[AWG]									
Max. cable cross-section with disconnect									

17.1.1 Line Power Supply 3 x 525-690 V AC

Table 18: Line Power Supply 3 x 525-690 V AC

Normal overload 110% for 1 minute							
Adjustable frequency drive Typical Shaft Output [kW]	P1K1 1.1	P1K5 1.5	P2K2 2.2	P3K0 3	P4K0 4	P5K5 5.5	P7K5 7.5
IP20 max. cable cross-section (line power, motor, brake and load sharing) [mm ²]/(AWG)	[0.2-4]/(24-10)						

Table 19: Line Power Supply 3 x 525-690 V AC IP20-Chassis/IP21-IP55/NEMA 1-NEMA12

Normal overload 110% for 1 minute						
Adjustable frequency drive Typical Shaft Output [kW]	P11K 11	P15K 15	P18K 18	P22K 22	P45K 45	P55K 55
Typical Shaft Output [HP] at 575V	16.4	20.1	24	33	60	75
Max. cable size (line power, motor, brake) [mm ²]/(AWG) ¹⁾	[35]/(1/0)				[50]/(1)	

Table 20: Line Power Supply 3 x 525-690 V AC IP21-IP55/NEMA 1-NEMA 12

Normal overload 110% for 1 minute					
Adjustable frequency drive Typical Shaft Output [kW]	P30K 30	P37K 37	P45K 45	P55K 55	P75K 75
Typical Shaft Output [HP] at 575V	40	60	60	75	100
Max. cable size (line power, motor, brake) [mm ²]/(AWG) ¹⁾	[95]/(4/0)				

¹⁾ American Wire Gauge

17.2 Connection Tightening Torques

Table 21: Tightening of Terminals

Enclosure	Power (kW)			Torque (Nm)						
	200-240 V	380-480/500 V	525-600 V	525-690 V	Line Power	Motor	DC Connection	Brake	Ground	Relay
A2	1.1-2.2	1.1-4.0			0.6	0.6	0.6	1.8	3	0.6
A3	3.0-3.7	5.5-7.5	1.1-7.5	1.1-7.5	0.6	0.6	0.6	1.8	3	0.6
A4	1.1-2.2	1.1-4.0			0.6	0.6	0.6	1.8	3	0.6
A5	1.1-3.7	1.1-7.5	1.1-7.5		0.6	0.6	0.6	1.8	3	0.6
B1	5.5-11	11-18	11-18		1.8	1.8	1.5	1.5	3	0.6
B2	15	22-30	22-30	11-30	4.5	4.5	3.7	3.7	3	0.6
B3	5.5-11	11-18	11-18		1.8	1.8	1.8	1.8	3	0.6
B4	15-18	22-37	22-37	11-37	4.5	4.5	4.5	4.5	3	0.6
C1	18-30	37-55	37-55		10	10	10	10	3	0.6
C2	37-45	75-90	75-90	37-90	14/24 ¹⁾	14/24 ¹⁾	14	14	3	0.6
C3	22-30	45-55	45-55	45-55	10	10	10	10	3	0.6
C4	37-45	75-90	75-90		14/24 ¹⁾	14/24 ¹⁾	14	14	3	0.6

¹⁾ For different cable dimensions x/y, where x <= 0.147 in² [95 mm²] and y >= 0.147 in² [95 mm²].

APPENDIX A: SET-UP FOR STANDBY PUMP ALTERNATION

This section describes how to alternate Taco SKS pump units based on elapsed time and how to configure the standby pump to energize in the event that the duty pump fails.

A.1 Overview

Two identical drives are used; one installed on each pump. One drive is configured as the “lead” drive and the other as the “standby” drive, but both drives participate equally in the alternation. The “lead” drive is the drive that controls the alternation process. If one drive enters an alarm condition, the other automatically assumes operation. Alternation attempts do not occur when one drive is in alarm.

This system requires one set of dry contacts for start/stop. Twenty-four VDC control voltage from both drives is wired to the lead drive’s relay 1. If the lead drive’s control circuitry is working, it supplies power. If the lead drive cannot provide control voltage, the standby drive automatically assumes control.

Figure A-1: Wiring for 2x0 Pump Alternation

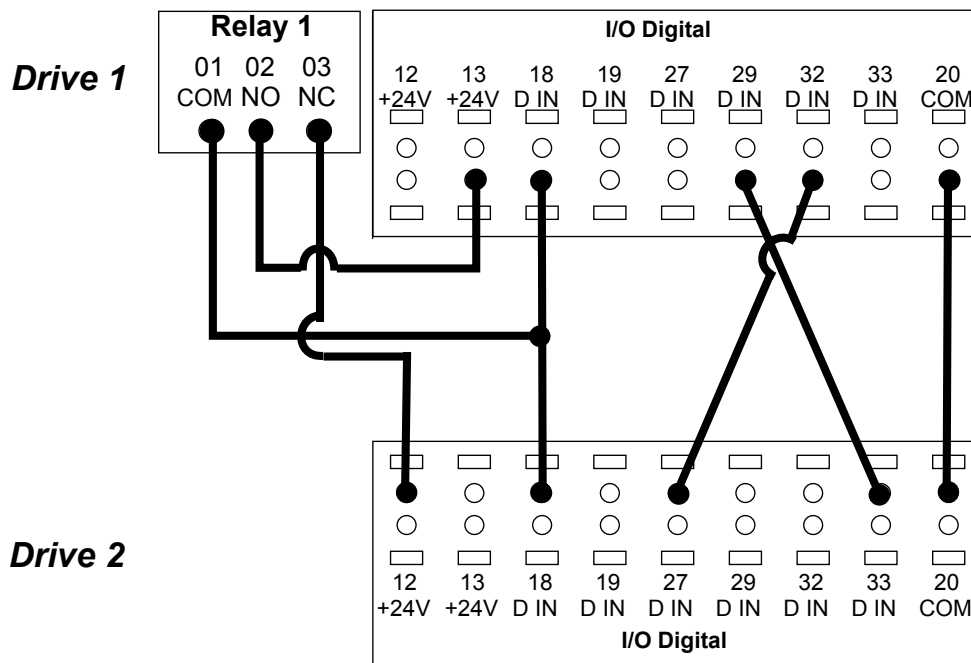

No external monitoring is needed. Pump alternation is controlled by the active set-up of each drive. The active set-up is controlled by the lead drive.

- Under normal conditions, the lead drive changes its active set-up based on the time delay specified in timer 0 by parameter setting 13–20.0.
- When the lead drive is operating normally in set-up 1, its digital output 29 is high. This state puts the standby drive into set-up 2.
- When the lead drive is operating normally in set-up 2, its digital output 29 is low. This state puts the standby drive into set-up 1.
- If the lead drive encounters an alarm condition or loses power, its digital output 29 is low. This state puts the standby drive into set-up 1, allowing it to take over operation.
- If the standby drive encounters an alarm condition or loses power, its digital output 27 is low. This condition causes the lead drive to move into set-up 1, allowing it to take over operation.

During system commissioning and other situations, the user may want to force pump alternation rather than rely on the setting in parameter 13-20.0.

- Logic rule 1 allows the user to override the timer by pressing the [ok] and [>] keys on the keypad (local control panel) simultaneously.
- Timer 1 offers “anti-bounce” protection for this key combination. After this combination of keys is pressed, the drive ignores any instance of the same combination again for two seconds.

A.2 Settings

Settings to operate the standby pump alternation have been programmed into the **My Personal Menu**. Follow this procedure to enable the drive's standby pump alternation capabilities.

1. Press the [Quick Menu] button.



2. Press the [OK] button to enter “My Personal Menu.”



3. Scroll down to Parameter 13-20 SL Controller Time and press [OK].



4. (Set the amount of time between pump alternations. Factory default is 24 hours. Maximum value is 99 hours.

- a. Parameter 13-20 = SL Controller Time.



5. Press [OK].



6. Scroll down to Parameter 0-10 Active Set-up and press [OK].



7. Change “Active Set-up 1” to “Multi Set-up”.
 - a. Parameter 0-10 = Active Set-up.

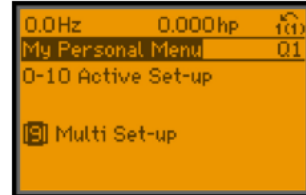

8. Press [OK].



9. Repeat this procedure on the Standby Drive.

A.2.1 Check Alternation

1. Ensure the lead and standby pumps are connected per wiring diagram in Figure A-1 above.
2. On the Lead drive (Drive A), Press the [Status] button to get back to the main screen.



3. The Lead drive (Drive A) should display in the upper right hand corner of the screen (Set-up 1).



Indicates what set-up the drive is currently in.

4. On the Standby drive (Drive B), Press the [Status] button to get back to the main screen.



5. The Standby drive (Drive B) should display  in the upper right hand corner of the screen (Set-up 2).

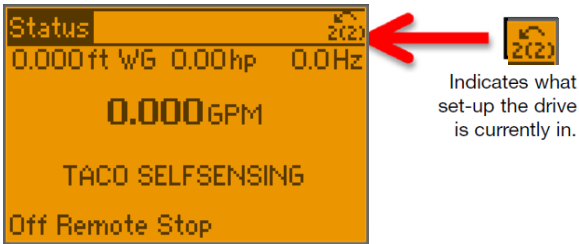



Indicates what set-up the drive is currently in.

6. If Drive B remains in Set-up 1 , check the following:

- a. Check that wire connections comply with Figure A-1.
- b. Check that both Drives' active set-ups are set to "Multi Set-up" per Section A.2 "Settings".

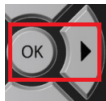
7. To test alternation, Press [OK] and [Right Arrow] at the same time.



8. Observe the two drives swap setups.
- a. Drive A switches to Set-up 2 , becoming the Standby Drive.
 - b. Drive B switches to Set-up 1 , becoming the Lead Drive.
9. Repeat step 7 as desired.
10. The pumps are now ready for alternation.

A.3 Parameters

Table 22: Lead and Lag Drive Parameters

Parameter Number	Parameter Name	Parameter Value	
		Set-up 1	Set-up 2
0-01	Language	[22] English US	[22]
0-03	Regional settings	[1] North America	[1] North America
0-10	Active set-up	[9] Multi set-up	[9] Multi set-up
0-11	Programming set-up	[1] Set-up 1	[2] Set-up 2
0-12	This set-up linked to	[0] Not linked	[1] Set-up 1
5-01	Terminal 27 mode	[1] Output	[1] Output
5-02	Terminal 29 mode	[1] Output	[1] Output
5-10	Terminal 18 digital input	[8] Start	[0] No operation
5-11	Terminal 19 digital input	[0] No operation	[0] No operation
5-12	Terminal 27 digital input	[0] No operation	[0] No operation
5-13	Terminal 29 digital input	Jog	Jog
5-14	Terminal 32 digital input	[0] No operation	[0] No operation
5-15	Terminal 33 digital input	[23] Set-up select bit 0	[23] Set-up select bit 0
5-19	Terminal 37 Safe Stop	Safe Stop Alarm	Safe Stop Alarm
5-30	Terminal 27 digital output	[160] No alarm	[160] No alarm
5-31	Terminal 29 digital output	[160] No alarm	[0] No operation
5-40	Relay 1	[1] Control ready	[1] Control ready
5-40.0	Function Relay	[1] Control ready	[1] Control ready
5-40.1	Function Relay	Running	Running
State controller start and stop events			
13-00	SL controller mode	[1] on	[1] on
13-01	Start event	[37] Digital input di32	[37] Digital input di32
13-02	Stop event	[26] Logic rule 0	[26] Logic rule 0
13-20.0	SL controller timer 0	024:00:00.000	024:00:00.000
13-20.1	SL controller timer 1	000:00:02.000	000:00:02.000
Logic rules			
13-40.0	Logic rule boolean 1	[37] Digital input di32	[37] Digital input di32
13-40.1	Logic rule boolean 1	[43] ok key	[43] ok key
13-41.0	Logic rule operator 1	[5] not and	[5] not and
13-41.1	Logic rule operator 1	[1] and	[1] and
13-42.0	Logic rule boolean 2	[1] true	[1] true
13-42.1	Logic rule boolean 2	[46] Right key	[46] Right key
13-43.1	Logic rule operator 2	[2] or	[2] or
13-44.1	Logic rule boolean 3	[30] SL time-out 0	[30] SL time-out 0
States			
13-51.0	SL controller event	[1] true	[1] true
13-51.1	SL controller event	[31] SL time-out 1	[31] SL time-out 1
13-51.2	SL controller event	[27] Logic rule 1	[27] Logic rule 1
13-51.3	SL controller event	[1] true	[1] true
13-51.4	SL controller event	[31] sl time-out 1	[31] sl time-out 1
13-51.5	SL controller event	[27] Logic rule 1	[27] Logic rule 1
13-52.0	SL controller action	[30] Start timer 1	[30] Start timer 1
13-52.1	SL controller action	[29] Start timer 0	[29] Start timer 0

Parameter Number	Parameter Name	Parameter Value	
		Set-up 1	Set-up 2
13-52.2	SL controller action	[3] Select set-up 2	[3] Select set-up 2
13-52.3	SL controller action	[30] Start timer 1	[30] Start timer 1
13-52.4	SL controller action	[29] Start timer 0	[29] Start timer 0
13-52.5	SL controller action	[2] Select set-up 1	[2] Select set-up 1

APPENDIX B: ON-SITE DRIVE MOUNTING TO WALL OR PUMP

Follow the steps below for on-site drive mounting to wall or to pump.

B.1 Match Pump and Drive Tags



IMPORTANT: Ensure the pump tag matches the VFD tag. The pump and drive will have identical tags as shown below.

Figure B-1: Example Tag



B.2 Mechanical Connections

For mechanical connections to pump, see section 7.2.

For mechanical connections to wall, see section 7.3.

B.3 Electric Code Compliance

Installation must be in compliance with national and local electric codes.

For electrical connections see Section “8 Electrical Connections” on page 9.

B.4 Before Start Safety Inspection



DANGER: HIGH VOLTAGE! If input and output connections have been connected improperly, there is potential for high voltage on these terminals. If power leads for multiple motors are improperly run in same conduit, there is potential for leakage current to charge capacitors within the frequency converter, even when disconnected from mains input. For initial start up, make no assumptions about power components. Follow pre-start procedures. Failure to follow pre-start procedures could result in personal injury or damage to equipment.

1. Input power to the unit must be OFF and locked out. Do not rely on the frequency converter disconnect switches for input power isolation.
2. Verify that there is no voltage on input terminals L1 (91), L2 (92), and L3 (93), phase-to-phase and phase-to-ground.
3. Verify that there is no voltage on output terminals 96 (U), 97 (V), and 98 (W), phase-to-phase and phase-to-ground.
4. Confirm continuity of the motor by measuring ohm values on U-V (96-97), V-W (97-98), and W-U (98-96).
5. Check for proper grounding of the frequency converter as well as the motor.
6. Inspect the frequency converter for loose connections on terminals.
7. Record the following motor-nameplate data: power, voltage, frequency, full load current, and nominal speed. These values are needed to program motor nameplate data later.
8. Confirm that the supply voltage matches voltage of frequency converter and motor.



CAUTION: Before applying power to the unit, inspect the entire installation as detailed in Table 23 on page 84. Check mark those items when completed.

Table 23: Inspection Checklist

Inspect for	Description	Check?
Auxiliary equipment	<ul style="list-style-type: none"> – Look for auxiliary equipment, switches, disconnects, or input fuses/circuit breakers that may reside on the input power side of the frequency converter or output side to the motor. Ensure that they are ready for full speed operation. – Check function and installation of any sensors used for feedback to the frequency converter. – Remove power factor correction caps on motor(s), if present. 	
Cable routing	<ul style="list-style-type: none"> – Ensure that input power, motor wiring, and control wiring are separated or in three separate metallic conduits for high frequency noise isolation. 	
Control wiring	<ul style="list-style-type: none"> – Check for broken or damaged wires and loose connections. – Check that control wiring is isolated from power and motor wiring for noise immunity. – Check the voltage source of the signals, if necessary. – The use of shielded cable or twisted pair is recommended. Ensure that the shield is terminated correctly. 	
Cooling clearance	<ul style="list-style-type: none"> – Measure that top and bottom clearance is adequate to ensure proper air flow for cooling. 	
EMC considerations	<ul style="list-style-type: none"> – Check for proper installation regarding electromagnetic compatibility. 	
Environmental considerations	<ul style="list-style-type: none"> – See equipment label for the maximum ambient operating temperature limits. – Humidity levels must be 5-95% non-condensing. 	
Fusing and circuit breakers	<ul style="list-style-type: none"> – Check for proper fusing or circuit breakers. – Check that all fuses are inserted firmly and in operational condition and that all circuit breakers are in the open position. 	
(grounding)	<ul style="list-style-type: none"> – The unit requires an earth wire(ground wire) from its chassis to the building earth (ground). – Check for good earth connections(ground connections) that are tight and free of oxidation. – Earthing (Grounding) to conduit or mounting the back panel to a metal surface is not a suitable earth (ground). 	
Input and output power wiring	<ul style="list-style-type: none"> – Check for loose connections. – Check that motor and mains are in separate conduit or separated screened cables. 	
Panel interior	<ul style="list-style-type: none"> – Inspect that the unit interior is free of dirt, metal chips, moisture, and corrosion. 	
Switches	<ul style="list-style-type: none"> – Ensure that all switch and disconnect settings are in the proper positions. 	
Vibration	<ul style="list-style-type: none"> – Check that the unit is mounted solidly or that shock mounts are used, as necessary. – Check for an unusual amount of vibration. 	

B.5 Applying Power to the Frequency Converter



DANGER: HIGH VOLTAGE! Frequency converters contain high voltage when connected to AC mains. Installation, start-up and maintenance should be performed by qualified personnel only. Failure to comply could result in death or serious injury.



WARNING: UNINTENDED START! When the frequency converter is connected to AC mains, the motor may start at any time. The frequency converter, motor, and any driven equipment must be in operational readiness. Failure to comply could result in death, serious injury, equipment, or property damage.

1. Confirm the input voltage is balanced within 3%. If not, correct input voltage imbalance before proceeding. Repeat this procedure after the voltage correction.
2. Ensure that optional equipment wiring, if present, matches the installation application.
3. Ensure that all operator devices are in the OFF position. Panel doors should be closed or cover mounted.
4. Apply power to the unit. DO NOT start the frequency converter at this time. For units with a disconnect switch, turn to the ON position to apply power to the frequency converter.

NOTE: If the status line at the bottom of the LCP reads “AUTO REMOTE COASTING” or “Alarm 60 External Interlock” is displayed, this indicates that the unit is ready to operate but is missing an input signal on terminal 27.

B.6 Run Automatic Motor Adaptation

Automatic motor adaptation (AMA) is a test procedure that measures the electrical characteristics of the motor to optimize compatibility between the frequency converter and the motor.

- The frequency converter builds a mathematical model of the motor for regulating output motor current. The procedure also tests the input phase balance of electrical power. It compares the motor characteristics with the data entered in parameters 1-20 to 1-25.
- It does not cause the motor to run or harm to the motor. Some motors may be unable to run the complete version of the test. In that case, select *Enable reduced AMA*.
- If an output filter is connected to the motor, select *Enable reduced AMA*.
- Run this procedure on a cold motor for best results.

NOTE: The AMA algorithm does not work when using PM motors.

NOTE: AMA has already been completed by Taco on all pump-mounted VFDs. You will only need to run AMA if the wire/motor lead is different from the one supplied by Taco.

To run AMA:

1. Press [Main Menu] to access parameters.
2. Scroll to parameter group 1-** *Load and Motor*.
3. Press [OK].
4. Scroll to parameter group 1-2* *Motor Data*.
5. Press [OK].
6. Scroll to 1-29 *Automatic Motor Adaptation (AMA)*.
7. Press [OK].
8. Select *Enable complete AMA*.
9. Press [OK].
10. Follow on-screen instructions.
11. The test runs automatically and indicates when it is complete.
12. Verify that parameters 1-25, 1-39 and 1-40 correspond to values on the motor nameplate following the AMA procedure.

B.7 Increase Warning Current Limit

Increase warning current limit in parameter 4-51 *Warning Current High* to the current specified on motor nameplate.

B.8 Check Motor Rotation

Before running the frequency converter, check the motor rotation. The motor will run briefly at 5Hz or the minimum frequency set in 4-12 *Motor Speed Low Limit [Hz]*.

1. Press [Quick Menu].
2. Scroll to Q2 *Quick Set-up*.
3. Press [OK].
4. Scroll to 1-28 *Motor Rotation Check*.
5. Press [OK].
6. Scroll to *Enable*.
7. The following text appears: “Note! Motor may run in wrong direction.”
8. Press [OK].
9. Follow the on-screen instructions.

To change the direction of rotation, remove power to the frequency converter and wait for power to discharge. Reverse the connection of any two of the three motor cables on the motor or frequency converter side of the connection.

B.9 Start-up Procedure

Follow Start-up procedure shown in “11 Start-Up Procedure” on page 37.

LIMITED WARRANTY STATEMENT

Taco, Inc. (Taco) will repair or replace without charge (at the company's option) any product or part which is proven defective under normal use within one (1) year from the date of start-up or one (1) year and six (6) months from date of shipment (whichever occurs first).

In order to obtain service under this warranty, it is the responsibility of the purchaser to promptly notify the local Taco stocking distributor or Taco in writing and promptly deliver the subject product or part, delivery prepaid, to the stocking distributor. For assistance on warranty returns, the purchaser may either contact the local Taco stocking distributor or Taco. If the subject product or part contains no defect as covered in this warranty, the purchaser will be billed for parts and labor charges in effect at time of factory examination and repair.

Any Taco product or part not installed or operated in conformity with Taco instructions or which has been subject to accident, disaster, neglect, misuse, misapplication, inadequate operating environment, repair, attempted repair, modification or alteration, or other abuse, will not be covered by this warranty.

Taco products are not intended for use to support fire suppression systems, life support systems, critical care applications, commercial aviation, nuclear facilities or any other applications where product failure could lead to injury to person, loss of life, or catastrophic property damage and should not be sold for such purposes.

If in doubt as to whether a particular product is suitable for use with a Taco product or part, or for any application restrictions, consult the applicable Taco instruction sheets or in the U.S. contact Taco at 401-942-8000 and in Canada contact Taco (Canada) Limited at 905-564-9422.

Taco reserves the right to provide replacement products and parts which are substantially similar in design and functionally equivalent to the defective product or part. Taco reserves the right to make changes in details of design, construction, or arrangement of materials of its products without notification.

TACO OFFERS THIS WARRANTY IN LIEU OF ALL OTHER EXPRESS WARRANTIES. ANY WARRANTY IMPLIED BY LAW

INCLUDING WARRANTIES OF MERCHANTABILITY OR FITNESS IS IN EFFECT ONLY FOR THE DURATION OF THE EXPRESS WARRANTY SET FORTH IN THE FIRST PARAGRAPH ABOVE.

THE ABOVE WARRANTIES ARE IN LIEU OF ALL OTHER WARRANTIES, EXPRESS OR STATUTORY, OR ANY OTHER WARRANTY OBLIGATION ON THE PART OF TES.

TACO WILL NOT BE LIABLE FOR ANY SPECIAL, INCIDENTAL, INDIRECT OR CONSEQUENTIAL DAMAGES RESULTING FROM THE USE OF ITS PRODUCTS OR ANY INCIDENTAL COSTS OF REMOVING OR REPLACING DEFECTIVE PRODUCTS.

This warranty gives the purchaser specific rights, and the purchaser may have other rights which vary from state to state. Some states do not allow limitations on how long an implied warranty lasts or on the exclusion of incidental or consequential damages, so these limitations or exclusions may not apply to you.

 **Taco Comfort Solutions**® A Taco Family Company

Taco, Inc., 1160 Cranston Street, Cranston, RI 02920 | Tel: (401) 942-8000 | FAX: (401) 942-2360

Taco (Canada), Ltd., 8450 Lawson Road, Suite #3, Milton, Ontario L9T 0J8 | Tel: (905) 564-9422 | FAX: (905) 564-9436

Visit our web site: www.TacoComfort.com | Printed in USA | ©2017 Taco, Inc.

